

Tactile Retina for Slip Detection

R. Maldonado-López¹, F. Vidal-Verdú², G. Liñán¹, E. Roca¹ and A. Rodríguez-Vázquez¹

¹Dept.of Analog and Mixed-Signal Circuit Design. IMSE-CNM-CSIC, Edificio CICA,
Avda. Reina Mercedes s/n, 41012-Sevilla, SPAIN, romaldo@imse.cnm.es

²Dto.Electrónica-Universidad de Málaga. Complejo Tecnológico, Campus Teatinos 29071 Málaga, SPAIN,
vidal@ctima.uma.es

Abstract - *The interest in tactile sensors is increasing as their use in complex unstructured environments is demanded, like in telepresence, minimal invasive surgery, robotics etc. The array of pressure data provided by these devices can be treated with different image processing algorithms to extract the required information. However, as in the case of vision chips or artificial retinas, problems arise when the array size and the computation complexity increase. Having a look at the skin, the information collected by every mechanoreceptor is not sent to the brain for its processing, but some complex pre-processing is performed to fit the limited throughput of the nervous system. This is specially important for high bandwidth demanding tasks. Experimental works report that neural response of skin mechanoreceptors encodes the change in local shape from an offset level rather than the absolute force or pressure distributions. Something similar happens in the retina, which implements a spatio-temporal averaging. We propose the same strategy in tactile preprocessing, and we show preliminary results illustrated for the case of slip detection, which is certainly demanding in computing requirements.*

Keywords - *tactile sensors, slip detection, bioinspired chips*

I. INTRODUCTION

Tactile sensors emulate behavior of the human skin to collect the information provided by the normal and tangential forces on its surface and their changes along time. Although many of them have been reported and fabricated, these devices have had a slow development specially because of the lack of knowledge about the sense of touch and of applications that push the research into this area [1]. Generally speaking, smart sensors are intended to operate in complex, poorly structured environments. Such kinds of applications have become recently common and will be much more ubiquitous in the future [2], for instance in medicine, where Minimal Invasive Surgery (MIS) requires tactile sensors and displays for the surgeon to touch inside the patient through a small incision. Tactile sensors are also of great interest for food processing industry, where fragile or soft objects could be manipulated at low temperatures. Finally, telepresence and Virtual Reality will also be areas where these devices may find their way as a new mainstream technology.

Ideally, a tactile sensor should be able to provide information about texture, stiffness, slippage, friction, local shape, etc. These sensors are basically arrays that do not implement any on-chip processing. Preprocessing might not be

mandatory for small arrays and/or for applications which do not imply real-time operation. However, when large arrays and real-time operation are a must, a certain preprocessing at the sensory plane which results in a reduction of the amount of information to be transmitted to the central decision unit is mandatory. In this case, detection and data processing circuits should be located near the sensor array, to avoid problems caused by large distance wiring, which could be solved by integrating them all within the same silicon substrate [3]. To illustrate this, let us consider slip detection as an application example. Slip detection aims the early notification of the slip of an object while being manipulated by a robot. In the case of a translation, the slip takes place if the following condition is met:

$$\frac{f_t}{f_n} \leq \mu \quad (1)$$

where μ is the friction coefficient, and f_t and f_n are the tangential and normal forces at the contact area. This equation can be employed as a first method to detect the occurrence of slip. However, it requires the estimation of the friction coefficient, which is most commonly unknown or very difficult to estimate. Some implementations train an artificial neural network to be able to detect slip without an explicit estimation of μ , but the results are limited because of the large number of variables involved [4]. Other approaches rely on the detection of microvibrations that happen once the slip occurs. These vibrations are generated by the sequence of stick-slip cycles during the slip, when the surface at the contact area between the indenter and the manipulated object stretches (stick) until the slip condition (1) is met and then snaps back (slip). Dynamic sensors or accelerometers can be used to detect such vibrations [5]. However, this can be an error prone method due to the interference of environmental vibrations generated in the course of multi finger manipulation [4]. Moreover, the incipient slip is a local phenomenon [6] and hence has to be detected locally by means of an array of sensors.

Returning to the human analogy, human skin relies on mechanoreceptors in the skin to detect slip [7]. Specifically, signals from the fast adapting FA nerve endings indicate the earliest stages of slip [5] which are followed by an unconscious increase in the grasp force to prevent further slippage.

In this paper, we propose a different approach that is

inspired in the human skin but also in its similarities with the retina. We consider that the tactile sensor output is in fact a tactile image, and it can be processed by algorithms that were originally intended for visual images like those implemented in artificial retinas. Thus, motion detection algorithms could also be tried in slip detection problems. Moreover, some artificial retinas are able to implement a spatio-temporal averaging that extends the useful operating range. This concept is fully bioinspired. The human retina is mainly sensitive to changes in its input, with little influence — only at the extremes of our vision limits — of the actual lighting conditions [8]. It has been observed that the skin also behaves similarly, and neural response of skin mechanoreceptors encodes the change in local shape from an offset level rather than the absolute force or pressure distributions [9]. The sensitivity to local instead of global variations makes the skin able to sense features in very irregular objects or surfaces with different textures. Specifically, the incipient slip is detected even if very different objects are manipulated.

II. ARCHITECTURE

As said above, we are interested in slip detection as a first problem to solve and explore the power of employing vision hardware resources in the tactile field. A first step could be the use of the architecture of the silicon retina described in [8]. It could be valid to detect slip since it is sensitive to changes in the signal from the visual sensors corresponding to movements, which has a clear correspondence in the detection of slip.

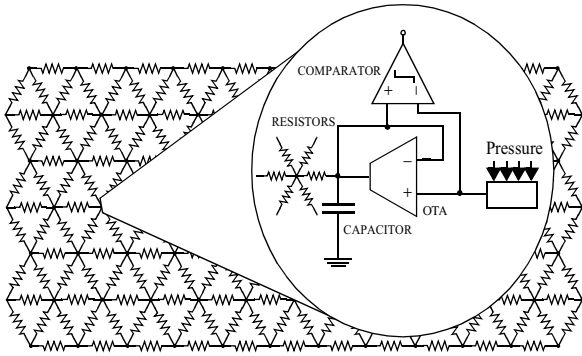

Fig. 1. The proposed architecture is similar to that in [8].

Fig.1 shows the selected architecture. A single tactel element is illustrated in the circular window. The resistive network computes a spatio-temporal (taking into account the capacitors) average of the signals provided by the unity-gain connected transconductance amplifier by which the force sensor drives it. The spatial scale of the weighting function depends on the product of the lateral resistance R and the conductance of the unity-gain connected amplifier G , and the larger the distance between two nodes, the lower the influence on each other. A second amplifier senses the difference across

the conductance G , that is the difference between the sensor output and the voltage at the corresponding network node. This processing allows a gain control on the sensor output that takes the spatio-temporal average as a reference. A first consequence is that the array is able to operate under very different situations corresponding to different maps of normal pressure detected by the tactile sensor.

Another important aspect of this network is its dynamic behavior. The capacitor associated to every node in the network implements a delay that could be characterized by its time constant $\tau = C/G$. In other words, the circuit implements a spatio-temporal high-pass filter. This feature can be exploited to detect the microvibrations produced by slip if the circuit dynamic response is properly tuned. This is what we have done in this paper, where we also have used a comparator as high gain amplifier at the output stage of the tactile retina node. Microvibrations are notified by a train of pulses with an amplitude determined by the output range of the comparator and a frequency determined by the frequency of the slip vibrations. It is important now to be aware of the dynamic requirements of the circuitry to detect slip, specifically what are the main components in the frequency spectrum of a stick-slip signal.

III. BUILDING BLOCKS

From the point of view of the dynamic response, which is our initial aim, the requirement for Fig.1 is that it must be sensitive to the frequency range of the slip specified in section IV. Since minimum frequencies to be detected are around 60Hz, this means that the time constant $\tau = C/G$ must be very large. We need then a large capacitance and a very small transconductance OTA in Fig.1.

Both goals can be achieved if we use previously reported techniques to implement very low frequency OTA-C filters [13]. Specifically, an impedance scaler circuit is used to get the desired high capacitance value while saving area. Fig.2 shows such circuit as we have implemented it in the architecture of Fig.1.

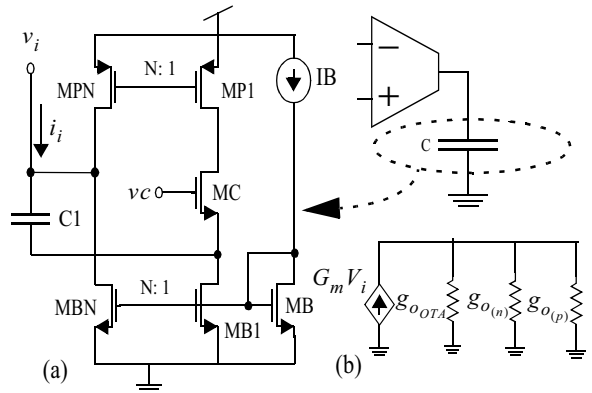

Fig. 2. Impedance scaler circuit (a) and simple small signal model of a filter with this circuit (b).

The obtained impedance is given by:

$$Z_i = \frac{v_i}{i_i} \approx \frac{1}{s(N+1)C} \quad (2)$$

where it has been supposed that the transconductance g_{mn} of the NMOS transistors is very high as compared to $g_{o(n)}$, $g_{o(p)}$ (output conductance of the n and p branches in Fig.2) and sC . As equation (2) states, the larger the value of N , the higher the final impedance value.

As said before, very small transconductance OTAs are also required to get a small time constant and detect slip. Three main design keys have been followed for that purpose: PMOS differential pair as core, current division and source degeneration. The implemented OTA is based on that reported in [13] which has been employed in very low frequency filters.

The resistors in the array of Fig.1 have been implemented like those used to degenerate the sources of transistors in the OTA. This consumes much less area than a network made of passive resistors. Moreover, it is also simpler than the horizontal resistor (HRes) reported in [8].

The last building block is a comparator placed at the output stage of our tactile sensor as output amplifier. Thus, we obtain a kind of digital signal, because microvibrations of the sensor output signal, in the range of the frequencies related to slip, will cause the output signal to oscillate from high to low state, thus generating the train of pulses mentioned in section II. We have chosen a one-step voltage comparator with a SOTAC (Symmetric Operational Transconductance Amplifier Comparator) structure.

IV. SLIPPAGE STIMULI

In order to gain insight into the slip signals characteristics, a set of experiments has been performed. Experimental results have been collected and studied. These data have been employed to extract a model of the slip stimuli to be employed in our simulations.

A. First set of stimuli

Fig.3 shows the first experimental set-up that has been employed to obtain a slip signal and examine its dynamic behavior.

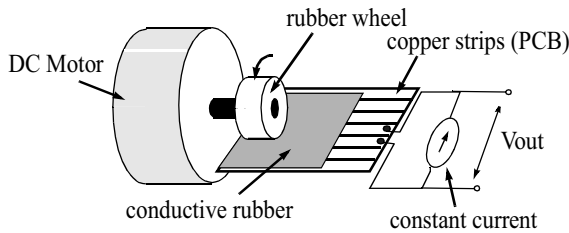

Fig.3. Simple experimental set-up to measure the frequency response of the slip.

A conductive rubber has been placed on a PCB board with a few parallel copper strips. The resistance of the rubber (Zoflex@ZL45.1) depends on the pressure exerted on it. If a constant current is injected between two strips, the voltage drop between these electrodes will be a measurement of the pressure right in the electrodes location. A DC motor has been used to produce a sustained slip condition.

Fig.4 shows the slip signal versus time (top) and its FFT as obtained from the scope (bottom). It can be observed that there is a significant response between 60 and 220Hz approximately, where the output is attenuated around 15dB with respect to the dc level. This result is coherent with observations from other authors [10][11]. It is also worthy to mention that the FA mechanoreceptors in the human skin have a maximum sensitivity also in this frequency range [7].

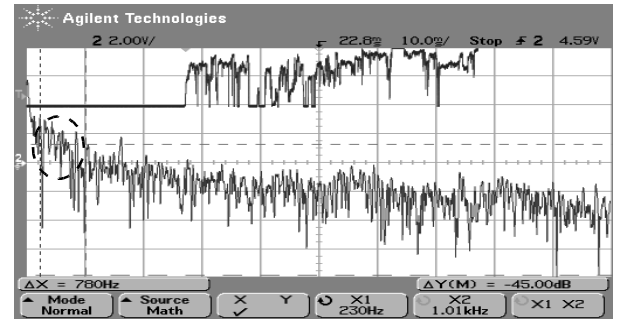

Fig.4. Experimental results. Slip signal versus time (top) and its FFT (bottom).

Taking into account the sharp nature of the changes in the stick-slip sequence, as observed experimentally, and the knowledge of the frequency range of interest, a possible model of the slip microvibrations to be used in our simulations could be a frequency modulated square signal. Such signal has a quite similar spectrum to that in Fig.4. for the measured slip signal.

Our first stimuli model is mainly based in our experimental information as well as in reported experimental data. As explained above, microvibrations due to slippage have been modeled by a linear frequency modulated square signal. Furthermore, a random component has been added to our model, taking into account possible noise effects. In order to get more complete results, we are interested in testing how different indenter shapes (thus, different pressure distribution shapes) could influence our tactile sensor behavior. To take this into account, we have added the square signal that models the slippage to the pressure distribution patterns reported in [4] for different indenter shapes: flat (4 mm wide), cylindrical (radius 10 mm) triangular (edge angle 120°), and parabolic.

B. Second set of stimuli

This stimuli have been obtained from an experimental set-up that consists in an inclined plane, with a tactile sensor fixed on its surface. Thus, if an object slides down the inclined plane,

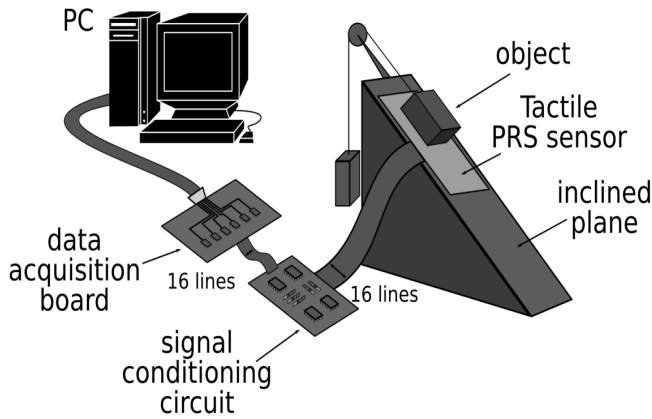

Fig.5. Second experimental set-up.

our sensor will collect the tactile data derived from this phenomenon.

The tactile sensor is made of a piezoresistive film (from an INTERLINK® pressure sensor) that has been placed on a PCB board with a set of comb shape electrodes. The result is a linear array with 16 taxels separated 2.54mm from each other. The transduction method is based on the variation of the material resistance when it is pressed. Actually, in this preliminary version the film has been attached with adhesive tape to the PCB substrate. This causes an stress that makes the sensor gives a non zero output even without any weight on it. An interface signal conditioning circuitry with 16 channels provides 16 voltage signals, which are read using a data acquisition board and sent to a computer (Fig.5).

Although much work -currently in progress- has to be done in order to get an improved version of this sensor, different experiments have been realized with this first implementation that show our approach is correct.

In Fig.6 we can observe some stimuli obtained from these

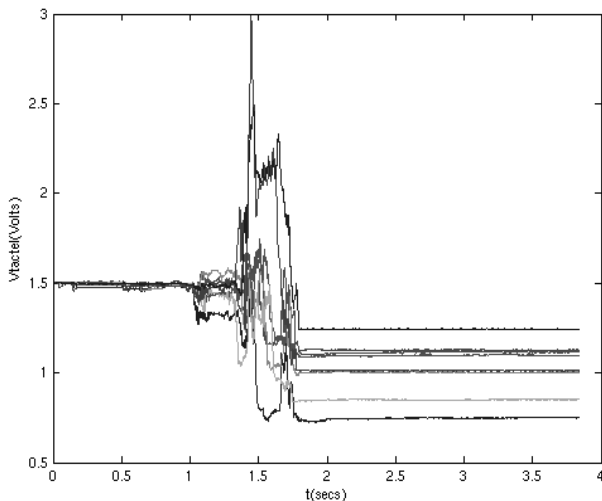

Fig.6. Experimental results from the second experimental set-up.

experiments. It shows the result of an experiment where the object remains still on the sensor surface until it is released (around $t = 1$ sec) and slides down the inclined plane. Since non idealities (like lack of linearity, hysteresis, creep and crosstalk that has been reported in the literature for this kind of sensors [1][12], and others derived from our experimental set up like the stress introduced by the adhesive tape) cause the taxels provide different measurements despite they theoretically are under similar conditions, the zero has been calibrated by making initially all outputs register the same average, i.e. the initial average or dc level of every output has been subtracted and a common average of 1.5 volts has been added to all of them. Note that this changes the dc level but keeps the other frequency components of the signal. Note also that this procedure does not calibrate the gain.

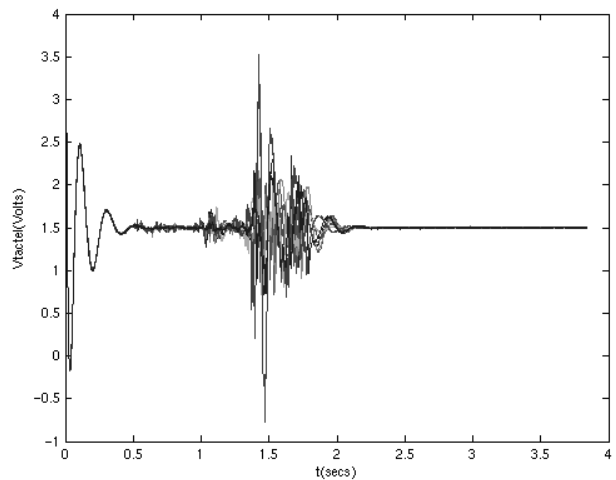

Fig.7. High-pass filtered stimuli.

Further processing can yet be done to obtain better stimuli until an improved sensor is fabricated. It consists in filtering the signal to eliminate the DC component and increase the gain to highlight the stick-slip signal. The result is shown in Fig.7.

Both signals depicted in Fig.6. and Fig.7. have been used to test the proposed approach and results are provided in Section V.

V. IMPLEMENTATION AND RESULTS

The so-called TPC16 chip (Tactile Processing Chip with 16 cells), has been designed and sent to the foundry (Fig.8). This chip consists on a 4 X 4 rectangular array of processing units with the building blocks described in section III. The size of each processing unit is 275 by 350 μm . Chip size, including pads is 2.2 x 2.2 mm^2 and has been implemented in a 0,35 μm standard CMOS process available through Europractice IC Services.

Switches added to the network resistors allow us to choose between three different configurations for the matrix of

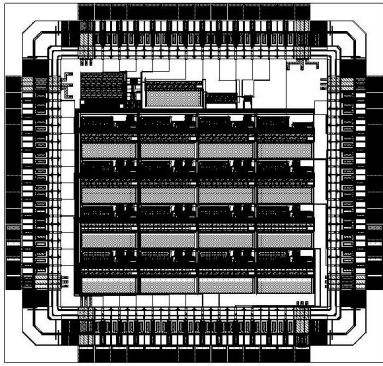

Fig.8. Layout of the TPC16 chip

processing units: 16 isolated cells, a 16-cells linear array, or a 4 X 4 rectangular arranged array. This feature will permit us to evaluate the influence of the resistive network under different stimuli.

Post layout Montecarlo simulations have been carried out. Fig.9 shows the frequency response at the output of the unity-gain connected OTA of each cell of the array. The cut-off frequency is around 60 Hz. To accomplish this specification, a capacitor of 20pF and a value of 10 for N (the gain of the impedance scaler) have been chosen.

In order to evaluate the performance of the architecture proposed in this paper, a set of simulations has been carried out. Fig.10. shows the obtained results from transient simulations of a linear tactile retina with 10 cells. Inputs are different indenters slipping at constant speed of 20 tactels/sec. Microvibrations are advised by a train of pulses. The train of pulses is better-conformed and more continuous in the case of flat indenters than for triangular or cylindrical indenters. The fact that the circuit is able to detect slip under so different pressure distributions or indenters shows the success of the local processing.

In order to confirm the feasibility of our design, a set of additional simulations have been performed. Stimuli collected with the second experimental set-up described in section IV, have been used as input sources for simulations with the TPC16 chip, and results are presented below.

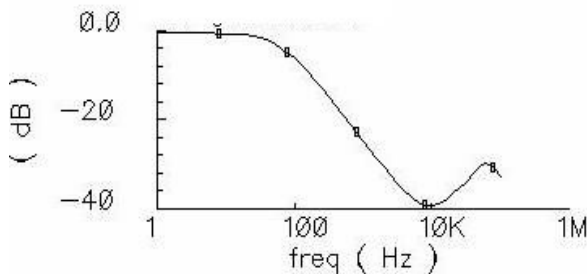

Fig.9. Frequency Response of one cell of the tactile retina

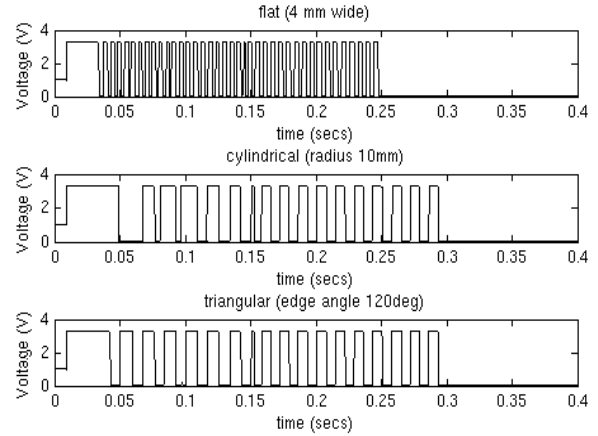

Fig.10. Simulation results for slip. Local average tactile retina.

First of all, as explained in section IV, is very important to do a calibration of these stimuli at the starting point, so that every tactel gives the same output when the object is not still slipping. This zero calibration will permit us to achieve relatively accurate results at the early beginning of the slip phenomenon, which are the most interesting instants for us. Thus, a software zero calibration has been performed on our stimuli. Simulation results corresponding to the processing of these slip stimuli with the TPC16, using its 16-cells linear array configuration, are presented in Fig.11.

We expected slip to be noticed by edges appearing in the output signals. We have observed that no edges appear while the object doesn't move. Conversely, when the object begins to slip, edges can be observed in almost all tactel outputs. However, during the slip, train of pulses forms only in some tactels. This is due the lack of calibration of the gain of the sensor.

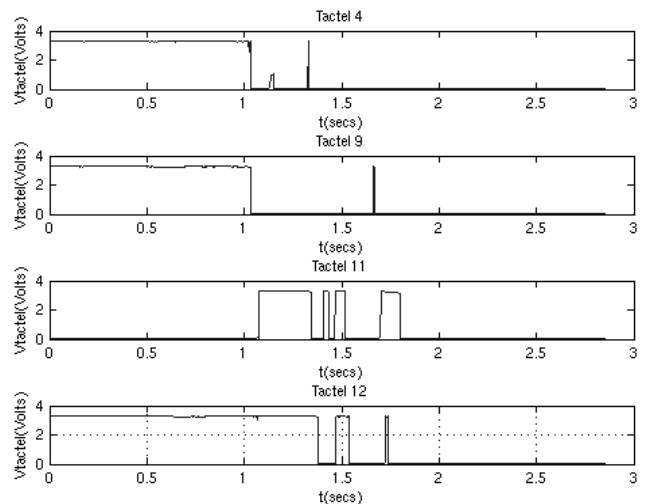

Fig.11. Post-layout simulation results. TPC16 in linear array configuration

In order to perform a gain software calibration, a high-pass filter have been applied to our stimuli, eliminating their DC component and increasing the gain, as explained in section IV. In this case, as expected, better results are achieved, as can be observed in Fig.12.

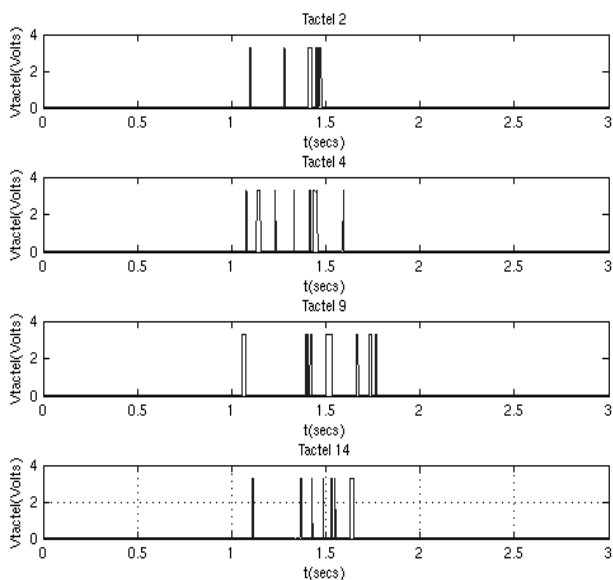

Fig.12. Post-layout simulation Results. TPC16 in linear array configuration

During the initial phase, when the object is still quiet, there are no variations in the output signals. Edges appear at the moment when the object begins to slip, and a train of pulses can be observed during the slippage of the object. Thus, this results are coherent with the previous simulations based on our stimuli model (Fig.10).

VI. CONCLUSIONS

This paper is intended to propose a new strategy to detect slip as an example of how resources developed for artificial retinas and vision chips can also be employed also to increase the capability of tactile sensors. Despite this is a first step, simulation results show that this approach, and specifically the use of the architecture reported in [8], is able to detect slip as we have modeled it even when different indenters are used.

Moreover, experimental data have been collected to confirm and tune the design of the slip sensor. Despite the

limitations due to the absence of hardware calibration, the preliminar results presented in this paper show the feasibility of the proposed strategy for slip detection and encourage us to carry on this way. At present, we continue working on the enhancement of the fabrication and calibration of the sensor. Experimental results using the TPC16 chip are expected to be presented at the conference.

ACKNOWLEDGEMENT

This work has been partially funded by project TIC2003-09817-C02, and has been motivated from maintained research collaboration from Sevilla and Málaga.

The authors thank the contribution of ZOFLEX® for providing samples of pressure-activated conductive rubber.

REFERENCES

- [1] M.H. Lee and H.R Nicholls, "Tactile sensing for mechatronics-a state of the art survey", *Mechatronics*, Vol. 9, pp.1-31, 1999.
- [2] M.H. Lee, "Tactile Sensing, New Directions, New Challenges", *The International Journal of Robotics Research*, pp. 636-643, 2000.
- [3] A. Iwashita, M. Shimojo, "Development of a Mixed Signal LSI for Tactile Data Processing", *IEEE International Conference on Systems, Man and Cybernetics*, Vol. 5, pp. 4408-4413, 2004.
- [4] G. Canepa, R. Petrigliano, M. Campanella and D. De Rossi, "Detection of Incipient Object Slippage by Skin-Like Sensing and Neural Network Processing", *IEEE Transactions on Systems and Cybernetics*, Vol. 28, pp.348-356, 1998.
- [5] R.D. Howe, "Tactile Sensing and Control of Robotic Manipulation", *Journal of Advanced Robotics*, Vol. 8, pp. 245-261, 1994.
- [6] S. A. Stansfield, "Experiments in Robotic Sensorimotor Control During Grasp", *IEEE Transactions on Systems, Man and Cybernetics*, Vol. 23, pp. 891-896, 1993.
- [7] R.D. Howe, M.R. Cutkosky, "Sensing Skin Acceleration for Slip and Texture Perception", *Proc. IEEE Robotics Automation*, pp. 145-150, 1989.
- [8] C. Mead, "Analog VLSI and Neural Systems", *Addison-Wesley*, 1989.
- [9] W. J. Peine and R. D. Howe, "Do Humans Sense Finger Deformation or distributed Pressure to Detect Lumps in Soft Tissue?", *Proc. of the ASME Dynamic System and Control Div*, Vol. 64, pp. 273-278, 1998.
- [10] E.G.M. Holweg, H. Hoeve, W. Jongkind, L. Marconi, C. Melchiorri, C. Bonivento, "Slip Detection by Tactile Sensors: Algorithms and Experimental Results", *Proc. of the 1996 IEEE International Conference on Robotics and Automation*, 1996.
- [11] I. Fujimoto, Y. Yamada, T. Morizono, Y. Umetani, T. Maeno, "Development of Artificial Finger Skin to Detect Incipient Slip for Realization of Static Friction Sensation", *IEEE Multisensor Fusion and Integration for Intelligent Systems*, pp. 15-21, 2003.
- [12] T. D'Alessio, "Measurement errors in the scanning of piezoresistive sensors arrays", *Sensors and Actuators*, Vol. 72, pp. 71-76, 1999.
- [13] J. Silva-Martínez and S. Solís-Bustos, "Design Considerations for High Performance Very low Frequency Filters", *Proceedings of the 1999 IEEE International Symposium on Circuits and Systems, ISCAS' 99*, Vol. 2, pp. 648-651, 1999.