

Unidimensional Modulation Technique for Cascaded Multilevel Converters

J. I. Leon, *Member, IEEE*, S. Vazquez, *Member, IEEE*, S. Kouro, *Member, IEEE*, L. G. Franquelo, *Fellow Member, IEEE*, J. M. Carrasco, *Member, IEEE* and J. Rodriguez, *Member, IEEE*

Abstract—This paper presents a simple and low computational cost modulation technique for multilevel cascaded H-bridge converters. The technique is based on geometrical considerations considering an unidimensional control region to determine the switching sequence and the corresponding switching times. In addition, a simple strategy to control the dc voltage ratio between the H-bridges of the multilevel cascaded converter is presented. Examples for the two-cell topology are shown but the proposed technique can be applied to develop modulation methods for a higher number of H-bridges. Experimental results are presented to validate the proposed technique.

I. INTRODUCTION

THE development of new simple and efficient modulation techniques for multilevel converters is a focus of research in the last 25 years. Pulse width modulation (PWM) and space vector modulation (SVM) are the most common ways to obtain the modulated voltage of a multilevel converter generating the reference voltage averaged over a switching period [1]–[3]. The large number of output voltage levels is an important constraint leading to complex hardware systems using multiple triangle carriers (in PWM techniques) or a high computational burden (in SVM techniques). Among the existing multilevel converter topologies, the cascaded H-bridge converter (CHB) is one of the most interesting ones due to its high modularity, fault tolerant capability, reduced number of power devices and high efficiency [4]–[6]. In Fig. 1, a single-phase two-cell CHB is shown. The output phase voltage V_{ab} is obtained as the addition of the output voltage of each H-bridge (also called cell) of the converter. In general, the dc voltage ratio of the two-cell CHB converter can be defined as $k:1$ (being k a real positive number) meaning that the voltage of the upper cell V_{C1} is k times higher than the voltage of the lower cell V_{C2} . In this paper, a simple and intuitive modulation method for CHB is presented. This modulation technique is based on geometrical considerations leading to the determination of the switching sequence and the switching times by very simple calculations. In addition, the

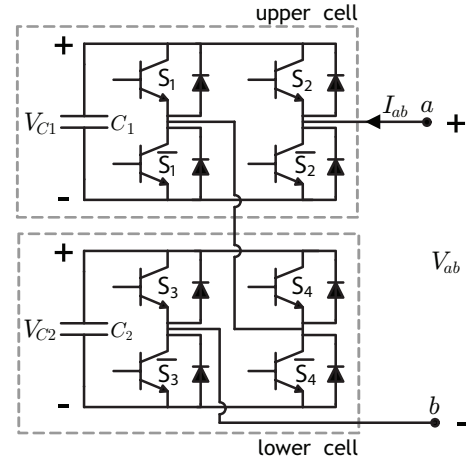

Fig. 1. Two-cell cascaded H-bridge converter.

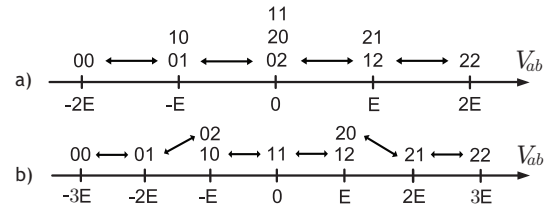

Fig. 2. 1D control region of the two-cell CHB (where $V_{C2} = E$ volts) with dc voltage ratio equal to a) 1:1 b) 2:1. The redundant switching states are chosen reducing the switching losses.

proposed method considers directly the redundant switching states in order to reduce the switching losses. This paper is an updated version of [7] including new experimental results and introducing improvements in the implementation of the proposed modulation technique.

II. 1D CONTROL REGION

As was introduced in [8], [9], a possible way to represent the switching states of multilevel converters is to plot the possible output voltages of the converter using a one dimensional (1D) control region. For example, the control region of the two-cell CHB with dc voltage ratio 1:1 and 2:1 are shown in Fig. 2. Each cell of the converter can obtain three different output voltages, $-V_{Ci}$, 0 and V_{Ci} , defined as H-bridge states 0, 1 and 2 respectively. In this figure, a state XY corresponds to the upper H-bridge having state X and the lower H-bridge having state Y.

Manuscript received August 22, 2008. Accepted for publication February 14, 2009. Copyright © 2009 IEEE. Personal use of this material is permitted. However, permission to use this material for any other purposes must be obtained from the IEEE by sending a request to pubs-permissions@ieee.org. J. I. Leon, S. Vazquez, L. G. Franquelo and J. M. Carrasco are with the Electronic Engineering Department, University of Seville (Spain), (e-mail: jileon@gte.esi.us.es). S. Kouro is with Department of Electrical and Computer Engineering, Ryerson University, Toronto (Canada) (e-mail: samir.kouro@ieee.org). J. Rodriguez is with the Electronic Engineering Department, Universidad Técnica Federico Santa María (Chile), (e-mail: jrp@usm.cl).

III. GEOMETRICAL MODULATION TECHNIQUE

The proposed modulation strategy generates the reference voltage (V_{ab}^*) as a linear combination of the two nearest switching states of the control region. Therefore, this calculation is reduced to a geometrical search of V_{ab}^* in the control region. The switching sequence is formed by two switching states XY called *upper₁-lower₁* and *upper₂-lower₂* with switching times t_1 and t_2 respectively. The switching times are also determined using very simple mathematical expressions. If the two nearest switching states of the control region have redundancies, those that reduce the number of commutations are selected. For example, in the case of CHBs with dc voltage ratios different of 1:1, the redundant switching states are chosen reducing the switching of the high dc voltage cell. The transitions between the different redundancies are illustrated with arrows in Fig. 2. In addition, the order of the switching states in the switching sequence is chosen according to the premises presented in [10], [11] in order to improve the harmonic performance of the output waveforms. The proposed modulation strategy is based on the following steps:

- 1) Normalization of the reference phase voltage V_{ab}^* using the dc voltage of the lower voltage cell (E volts) using expression

$$a = \frac{V_{ab}^*}{E}. \quad (1)$$

- 2) Determination of a_i factor as $\text{floor}(a)$ where operator $\text{floor}(x)$ rounds the elements of x to the nearest integer towards minus infinity.
- 3) Determination of the switching times per unit of the two switching states applying

$$\begin{aligned} t_1 &= a - a_i \\ t_2 &= 1 - t_1. \end{aligned} \quad (2)$$

- 4) Geometrical search of the reference phase voltage V_{ab}^* in the 1D control region using factor a_i .

As an example, the flow diagram of the proposed geometrical modulation technique for the two-cell CHB with dc voltage ratio 1:1 and 2:1 are shown in Fig. 3. The flow diagram of the dc voltage ratio 3:1 case was shown in the previous version of this paper [7]. As can be observed, the resulting flow diagrams are simple and consequently the computational cost is very low.

The proposed technique can be extended to CHB with more than two power cells. The analysis to extend this modulation technique for converter with more power cells rises proportionally in complexity, since the number of cases to be studied increases. However, this study can be done offline and it can be noticed that the online calculations needed to execute the corresponding modulation technique do not increase significantly.

IV. DC VOLTAGE RATIO CONTROL

An interesting application of the CHB is the grid connection without use of the input transformer that provides the isolated dc sources or also as active filter. However, the dc voltages control is a challenge in these applications [12]–[15]. A simple

strategy to control the dc voltage ratio of the two-cell CHB is introduced with the proposed geometrical modulation to be applied to existing rectifier or grid connection control strategies. The controller used in this paper to manage the sum of the dc voltages of the two-cell CHB was introduced in [16]. However, the total dc voltage is shared and controlled between the cells of the CHB applying the proposed modulation with simple additional dc voltage ratio considerations.

The output of the controller is the reference phase voltage V_{ab}^* which is the input of the proposed geometrical modulation technique. The technique to control the dc voltage ratio between the cells is based on the elimination of the switching states which tend to unbalance the dc voltage ratio [17]. In Table I, the switching states to be eliminated of the 1D control region are summarized depending on the actual dc voltage ratio and the sign of the phase current I_{ab} . These switching states are eliminated from the 1D control region shown in Fig. 2, leading to new flow diagrams to develop the geometrical modulation technique. For instance, the dc voltage ratio 2:1 has been studied in this paper. The flow diagrams to carry out the modulation achieving the control of the dc voltage ratio 2:1 are introduced in Fig. 4. The 1:1 case and the 3:1 case were presented in the previous version of this paper [7].

V. EXPERIMENTAL RESULTS

Firstly, the proposed geometrical modulation technique for the two-cell CHB working as an inverter is applied generating a pure 50 Hz sinusoidal reference with modulation index equal to 0.9. The switching frequency is 2 kHz and the CHB is connected to a RL load ($R=20 \Omega$, $L=15$ mH). The obtained results are shown in Fig. 5 for dc voltage ratios equal to 1:1 ($V_{C1}=V_{C2}=90$ V), 2:1 ($V_{C1}=200$ V, $V_{C2}=100$ V) and 3:1 ($V_{C1}=270$ V, $V_{C2}=90$ V). Note that for dc voltage ratios 2:1 and 3:1, the commutations and consequently the switching losses of the high power cell are reduced. It can be noticed that in the 1:1 case (Fig. 5 a) both cells equally share (in average) the power demanded by the load due to the nature of the proposed modulation and control strategy. In other cases such as 2:1 and 3:1, as the same current flows through all the cells and each cell contributes with a voltage proportional to its dc-link voltage, the H-bridges share the power in a ratio similar to the dc voltage ratio of the cells of the CHB (Fig. 5 b and Fig. 5 c). This phenomenon could be seen as a drawback in terms of switch usage and loss of modularity. However, the benefits are a strong reduction in the switching losses and an improvement of the power quality with same number of power semiconductors.

Secondly, the application of the proposed method for a CHB controlled rectifier connected to the grid through an

TABLE I
SWITCHING STATES TO BE AVOIDED TO CONTROL THE DC VOLTAGE RATIO $k:1$

Voltage unbalance	Forbidden states with $I_{ab} > 0$	Forbidden states with $I_{ab} < 0$
$V_{C1} > kV_{C2}$	20,21,10	02,12,01
$V_{C1} < kV_{C2}$	02,12,01	20,21,10

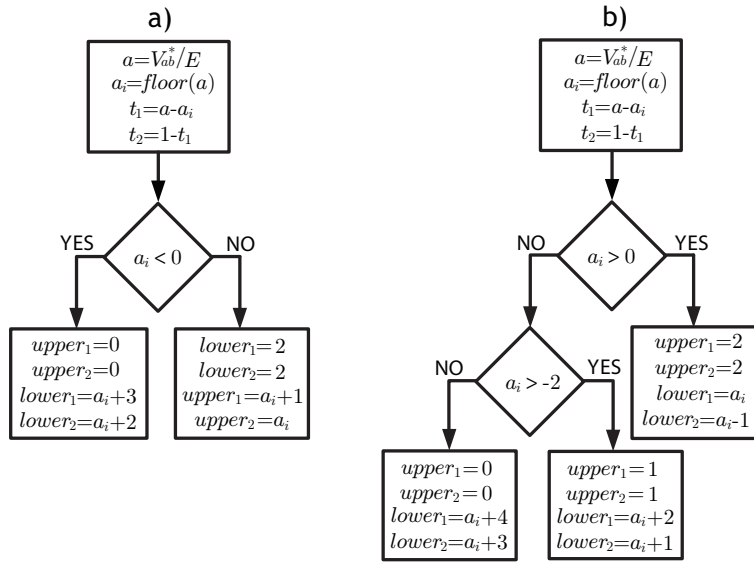

Fig. 3. Flow diagram of the proposed geometrical modulation technique (where $V_{C2} = E$ volts) for the two-cell CHB with dc voltage ratio equal to a) 1:1 b) 2:1

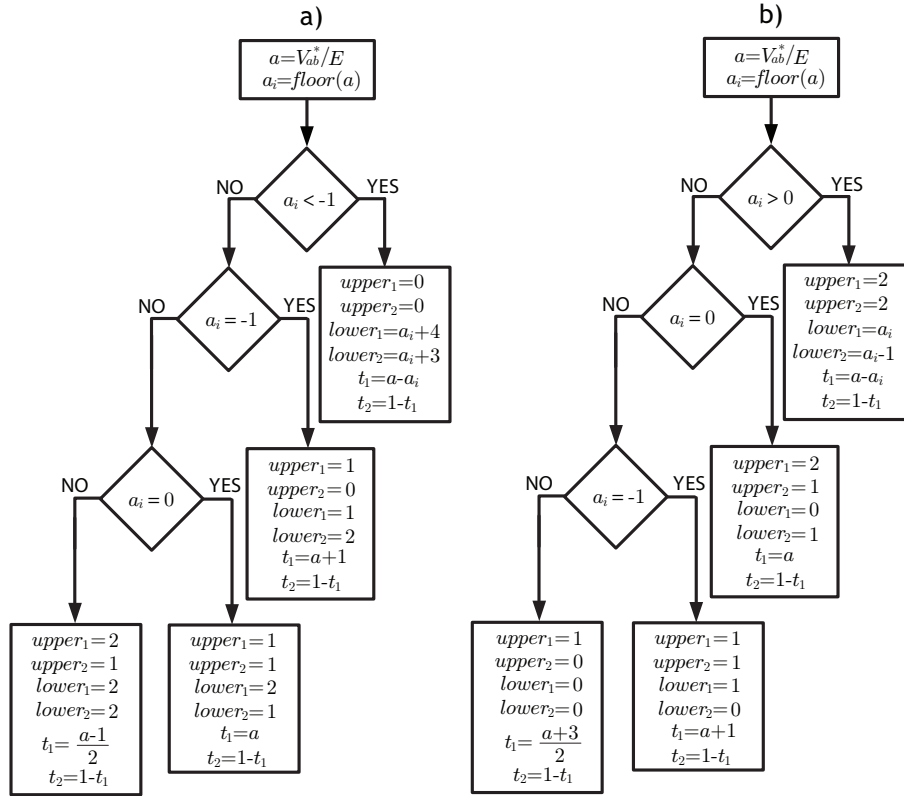
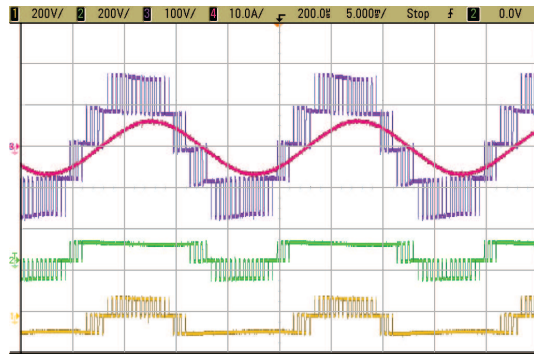

Fig. 4. Flow diagram of the geometrical modulation technique (where $V_{C2} = E$ volts) for a dc voltage ratio control equal to 2:1 when the eliminated switching states are a) 20, 21 and 10 b) 02, 12 and 01.

inductance ($L=3$ mH) is tested. The switching frequency is 2.5 kHz. Experimental results are presented achieving dc voltage ratios 1:1, 2:1 and 3:1 in Fig. 6. In the experiments, a load step from no load to connecting unbalanced resistive loads ($R_1=20 \Omega$ and $R_2=10 \Omega$ for upper and lower cells respectively) to the dc voltages of the CHB is shown. As conclusion, a high quality dynamic behavior of the dc voltage ratio control

strategy is achieved. It is clear that the proposed geometrical modulation with the dc voltage ratio strategy achieves an accurate dc voltage control of each cell, despite that the external rectifier controller is only in charge of the total dc voltage control. If the capacitor voltages are not perfectly controlled a possible solution to minimize the related distortion in the output waveforms is to apply a feed-forward modulation



(a)

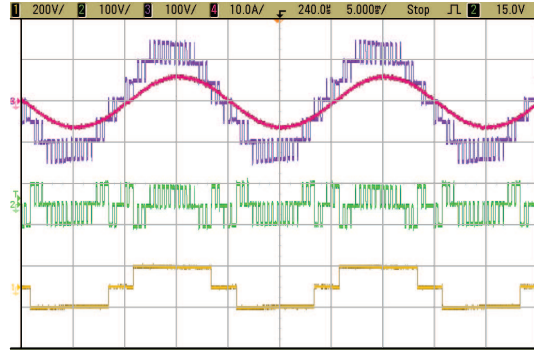

(b)

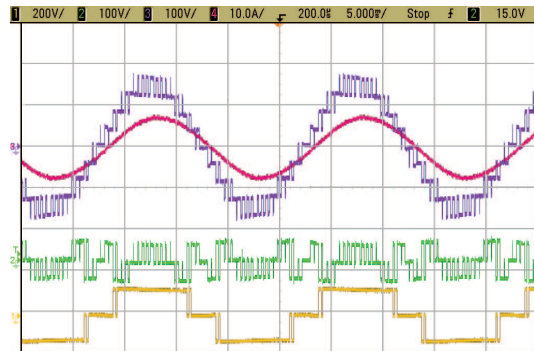

(c)

Fig. 5. Experimental results for inverter operation with dc voltage ratio: a) 1:1, b) 2:1 and c) 3:1. In all the figures from bottom to top: Channel 1: Output voltage of upper cell; Channel 2: Output voltage of lower cell; Channel 3: Phase voltage V_{ab} ; Channel 4: Phase current I_{ab}

technique [17].

As can be observed from Fig. 7, the elimination the unbalancing switching states leads to a slight distortion in the phase voltage V_{ab} when the desired dc voltage ratio is not 1:1. This is the trade-off to achieve asymmetric dc voltage ratios. In order to analyze this phenomenon, the total harmonic distortion (THD) of V_{ab} is studied depending on the value of the modulation index for dc voltage ratios 1:1, 2:1 and 3:1. The switching frequency is 2 kHz and the total active power provided by the two-cell CHB is 6 kW. The converter is connected to resistive loads in such a way that the power ratio between the cells coincides with the dc voltage ratio. The obtained results are shown in Fig. 8 where the THD is calculated considering harmonic order up to 49th. In this figure, the modulation index is defined as the ratio between the

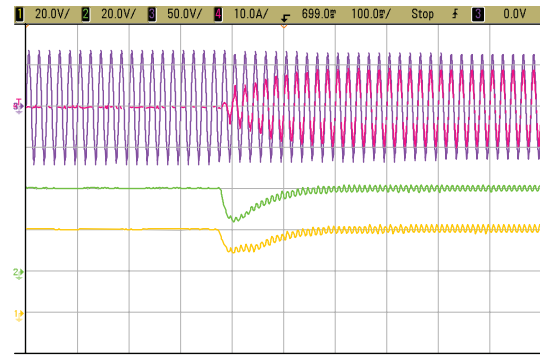

(a)

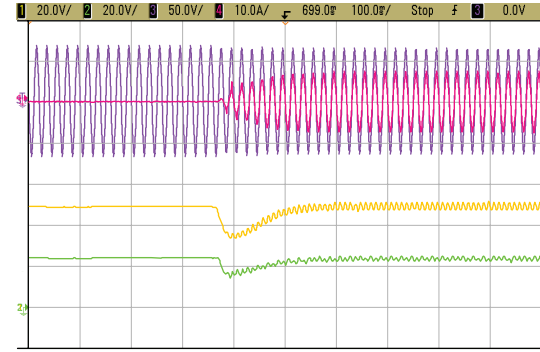

(b)

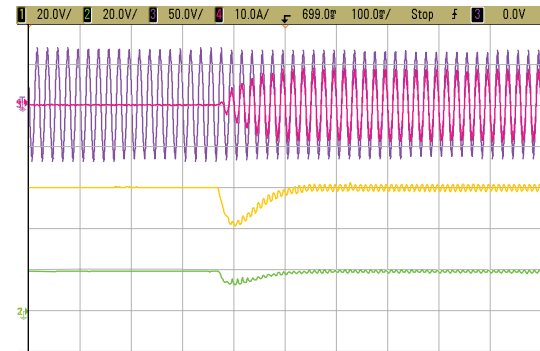

(c)

Fig. 6. Experimental results of the proposed geometrical modulation technique with control of the dc voltage ratio: a) 1:1 ($V_{C1}^* = V_{C2}^* = 40$ V), b) 2:1 ($V_{C1}^* = 2V_{C2}^* = 50$ V) and c) 3:1 ($V_{C1}^* = 3V_{C2}^* = 60$ V). Grid voltage $V_s = 50$ V_{rms}. In all the figures from bottom to top: Channels 1-2: Voltage of the cells V_{C1} and V_{C2} , Channel 3: Grid voltage V_s , Channel 4: Phase current I_{ab}

amplitude of the fundamental component of the phase voltage and maximum possible output dc voltage of the converter. From this result, it can be seen that the dc voltage ratio 2:1 is the best one in order to obtain a better performance in terms of THD. Ratio 1:1 has no additional distortion since the eliminated switching states have redundant allowed states keeping the five output voltage levels. In ratio 2:1, there is a better THD compared to 1:1 despite of the eliminated switching states (some of them have no redundancy) because 2:1 has seven output levels, compensating the distortion introduced by the dc voltage ratio algorithm. On the other hand, ratio 3:1 presents higher THD since there are no redundancies available for all switching states leading to a higher distortion when they are eliminated. The possible nine output levels that can

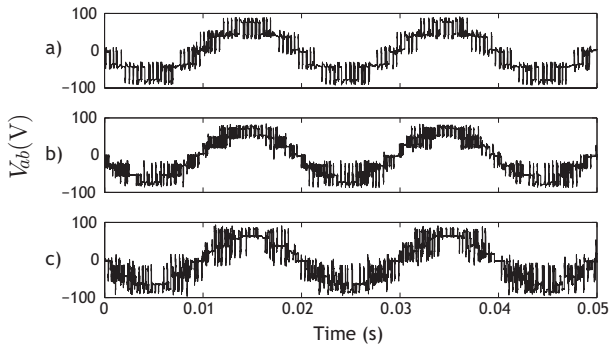

Fig. 7. Phase voltage V_{ab} using the proposed geometrical modulation technique with control of the dc voltage ratio. Dc voltage ratio a) 1:1 b) 2:1 c) 3:1

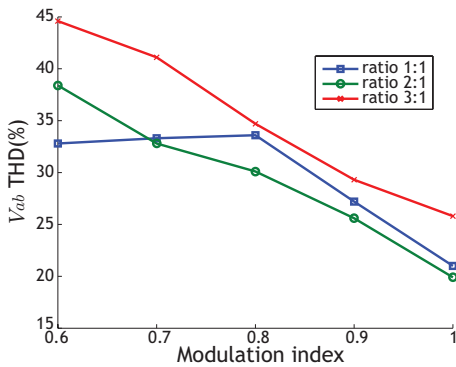

Fig. 8. Total harmonic distortion versus modulation index of the obtained phase voltage V_{ab} depending on the desired dc voltage ratio.

be generated using ratio 3:1 do not compensate this distortion.

VI. CONCLUSIONS

A simple and low computational cost modulation method for multilevel cascaded converters has been presented. The modulation method determines the switching sequence and the switching times based on geometrical considerations using an unidimensional control region. The reference phase voltage V_{ab}^* is generated using a linear combination of the two nearest switching states in the control region reducing the switching losses. Several examples using a two-cell CHB have been introduced depending on the dc voltage ratio of the converter. Experimental results are shown in order to validate the proposed strategies. The same method can be applied to CHB with a higher number of cells extending the control region and developing similar flow diagrams to determine the switching sequence and the switching times.

In addition, a simple strategy to control the dc voltage ratio of each cell of the two-cell CHB has been introduced. This technique is based on the elimination of the inappropriate switching states from the 1D control region. Once these switching states are eliminated, new flow diagrams are used to carry out the geometry-based modulation using reduced versions of the 1D control regions.

The phase voltage V_{ab} quality achieved by the proposed modulation strategy is similar to other well-known PWM techniques such as level-shifted PWM or hybrid PWM techniques.

However, using the proposed modulation technique with dc voltage ratio 1:1, an equal usage of the power semiconductors under all possible values of the modulation index is obtained. In addition, for other dc voltage ratios, the commutations of the higher voltage H-bridge have been reduced leading to a reduction of the commutation losses of the system making the proposed technique very attractive improving the overall efficiency of the converter. On the other hand, when the CHB is operating as a rectifier, the proposed modulation strategy has been modified in order to control the dc voltage ratio using the redundant switching state concept what cannot directly be considered by other PWM techniques.

Experimental results are presented to show the operation of the proposed modulation technique with the dc voltage ratio control for a two-cell CHB. The results show that the proposed modulation technique with the dc voltage control achieve high quality results with very low computational cost.

ACKNOWLEDGMENT

The authors gratefully acknowledge financial support provided by the Spanish Ministry of Science and Technology under project TEC2006-03863, by the Chilean National Fund of Scientific and Technological Development (FONDECYT), under grant no. 1080582 and by the Universidad Técnica Federico Santa María.

REFERENCES

- [1] D. G. Holmes and T. A. Lipo, "Pulse Width Modulation for Power Converters - Principles and Practice," IEEE Press, 2003.
- [2] R. Naderi and A. Rahmati, "Phase-Shifted Carrier PWM Technique for General Cascaded Inverters," *IEEE Trans. Power Electron.*, vol. 23, no. 3, pp. 1257–1269, May 2008.
- [3] Y. Wenxi, H. Haibing and L. Zhengyu, "Comparisons of Space-Vector Modulation and Carrier-Based Modulation of Multilevel Inverter," *IEEE Trans. Power Electron.*, vol. 23, no. 1, pp. 45–51, Jan. 2008.
- [4] J. Rodriguez, S. Bernet, Bin Wu, J. O. Pontt and S. Kouro, "Multilevel Voltage-Source-Converter Topologies for Industrial Medium-Voltage Drives," *IEEE Trans. Ind. Electron.*, vol. 54, no. 6, pp. 2930–2945, Dec. 2007.
- [5] L. G. Franquelo, J. Rodriguez, J. I. Leon, S. Kouro, R. Portillo and M. M. Prats, "The age of multilevel converters arrives," *IEEE Trans. Ind. Electron. Magazine*, vol. 2, no. 2, pp. 28–39, June 2008.
- [6] D. Krug, S. Bernet, S. S. Fazel, K. Jalili and M. Malinowski, "Comparison of 2.3-kV Medium-Voltage Multilevel Converters for Industrial Medium-Voltage Drives," *IEEE Trans. Ind. Electron.*, vol. 54, no. 6, pp. 2979–2992, Dec. 2007.
- [7] J. I. Leon, S. Vazquez, A. J. Watson, P. W. Wheeler, L. G. Franquelo and J. M. Carrasco, "A simple and low cost modulation technique for single-phase multilevel cascade converters based on geometrical considerations," *IEEE International Conference on Industrial Technology 2008 (ICIT'08)*, pp. 1–6, 21-24 April 2008, Chengdu (China).
- [8] J. I. Leon, R. Portillo, L. G. Franquelo, S. Vazquez, J. M. Carrasco and E. Dominguez, "New space vector modulation technique for single-phase multilevel converters," *IEEE International Symposium on Industrial Electronics (ISIE'07)*, pp. 617–622, 4-7 June 2007, Vigo (Spain).
- [9] J. I. Leon, R. Portillo, S. Vazquez, J. J. Padilla, L. G. Franquelo and J. M. Carrasco, "Simple Unified Approach to Develop a Time Domain Modulation Strategy for Single-Phase Multilevel Converters," *IEEE Trans. Ind. Electron.*, vol. 55, no. 9, pp. 3239–3248, Sept. 2008.
- [10] S. Kouro, J. Rebolledo and J. Rodriguez, "Reduced Switching-Frequency-Modulation Algorithm for High-Power Multilevel Inverters," *IEEE Trans. Ind. Electron.*, vol. 54, no. 5, pp. 2894–2901, Oct. 2007.
- [11] B. P. McGrath, D. G. Holmes and T. Lipo, "Optimized space vector switching sequences for multilevel inverters," *IEEE Trans. Power Electron.*, vol. 18, no. 6, pp. 1293–1301, Nov. 2003.

- [12] A. J. Watson, P. W. Wheeler and J. C. Clare, "A Complete Harmonic Elimination Approach to DC Link Voltage Balancing for a Cascaded Multilevel Rectifier," *IEEE Trans. Ind. Electron.*, vol. 54, no. 6, pp. 2946–2953, Dec. 2007.
- [13] J. A. Barrena, L. Marroyo, M. A. R. Vidal and J. R. T. Apraiz, "Individual Voltage Balancing Strategy for PWM Cascaded H-Bridge Converter-Based STATCOM," *IEEE Trans. Ind. Electron.*, vol. 55, no. 1, pp. 21–29, Jan. 2008.
- [14] H. Iman-Eini, J. L. Schanen, S. Farhangi and S. Wang, "Design of Cascaded H-Bridge Rectifier for Medium Voltage Applications," in *IEEE Power Electronics Specialists Conference (PESC 2007)*, pp. 653–658, 17–21 June 2007, Orlando (USA).
- [15] Jian Wang and Yongdong Li, "PWM rectifier in power cell of cascaded H-bridge multilevel converter," in *International Conference on Electrical Machines and Systems (ICEMS 2007)*, pp. 18–21, 8–11 Oct. 2007, Seoul (Korea).
- [16] S. Vazquez, J. I. Leon, J. M. Carrasco, E. Galvan, J. A. Sanchez and E. Dominguez, "Controller Design for a Single-Phase Two-Cell Multilevel Cascade H-Bridge Converter," *IEEE International Symposium on Industrial Electronics (ISIE'08)*, pp. 1–6, 30 June – 2 July 2008, Cambridge (UK).
- [17] J. I. Leon, S. Vazquez, A. J. Watson, L. G. Franquelo, P. W. Wheeler and J. M. Carrasco, "Feed-forward Space Vector Modulation for Single-Phase Multilevel Cascade Converters with any dc voltage ratio," *IEEE Trans. Ind. Electron.*, vol. 56, no. 2, pp. 315–325, Feb. 2009.



Jose I. Leon (S'04, M'07) was born in Cádiz, Spain, in 1976. He received the B.S. and M.S. and PhD degrees in telecommunications engineering from the University of Seville (US), Spain, in 1999, 2001 and 2006 respectively. In 2002, he joined the Power Electronics Group, US, working in R&D projects. Currently, he is an Associate Professor with the Department of Electronic Engineering, US. His research interests include electronic power systems, modeling, modulation and control of power converters and industrial drives.



Sergio Vazquez (S'04) was born in Seville, Spain, in 1974. He received the B.S. and M.S. degrees in industrial engineering from the University of Seville (US) in 2003 and 2006, respectively. In 2002, he was with the Power Electronics Group, US, working in R&D projects. He is currently an Assistant Professor with the Department of Electronic Engineering in the US. His research interests include electronic power systems, modeling, modulation and control of power electronic converters and power quality in renewable generation plants.



Samir Kouro (S'04, M'08) was born in Valdivia, Chile, in 1978. He received the M.Sc. and Ph.D. degrees in electronics engineering from the Universidad Técnica Federico Santa María (UTFSM), Valparaíso, Chile, in 2004 and 2008 respectively. From 2004 to 2008 he was a Research Assistant, and from 2008 to 2009 Associated Researcher at the Electronics Engineering Department of UTFSM. Currently he is a Post Doctoral Fellow at Ryerson University, Toronto, Canada. In 2004 he was distinguished as the youngest researcher of Chile in

being granted with a governmental funded research project (FONDECYT) as Principal Researcher. His research interests include power converters, adjustable speed drives, and renewable energy conversion.



Leopoldo G. Franquelo (M'84, SM'96, F'05) was born in Málaga, Spain. He received the M.Sc. and Ph.D. degrees in electrical engineering from the University de Seville (US), Seville, Spain in 1977 and 1980 respectively. His current research interest lies on modulation techniques for multilevel inverters and its application to power electronic systems for renewable energy systems. He was the Vice-President of the Industrial Electronics Society (IES) Spanish Chapter (2002 - 2003), member at Large of the IES AdCom (2002 - 2003). He was the Vice-

President for Conferences of the IES (2004 - 2007), in which he has also been a Distinguished Lecturer since 2006. He has been an Associated Editor for the *IEEE Transactions on Industrial Electronics* since 2007. Since January 2008 he is President Elect of *IEEE Industrial Electronics Society*.



Juan M. Carrasco (M'97) was born in San Roque, Spain. He received the M.Eng. and Dr.Eng. degrees in industrial engineering from the University of Seville (US), Seville, Spain, in 1989 and 1992, respectively. From 1990 to 1995, he was an Assistant Professor with the Department of Electronic Engineering in the US where he is currently an Associate Professor. He has been working for several years in the power electronic field where he was involved in the industrial application of the design and development of power converters applied to renewable energy technologies. His current research interests are in distributed power generation and the integration of renewable energy sources.



Jose Rodriguez (M'81, SM'94) received the Engineer and the Dr.-Ing degrees from the Universidad Técnica Federico Santa María in Chile and the University of Erlangen in Germany in 1977 and 1985 respectively, both in Electrical Engineering. He works as Professor since 1977 at Universidad Técnica Federico Santa María in Valparaíso, Chile. From 2001 to 2004 he was appointed as Director of the Electronics Engineering Department. From 2004 to 2005 he served as Vice-Rector of academic affairs, and in 2005 he was elected Rector of the same

university, position he holds till today. During his sabbatical leave in 1996, he was responsible for the mining division of the Siemens Corporation in Chile. He has a large consulting experience in the mining industry, especially in the application of large drives like cycloconverter-fed synchronous motors for SAG mills, high power conveyors, controlled ac drives for shovels and power quality issues. His main research interests include multilevel inverters, new converter topologies and adjustable speed drives. Professor Rodríguez has directed over 40 R&D projects in the field of Industrial Electronics, he has coauthored over 250 journal and conference papers, and contributed with one book chapter. His research group has been recognized as one of the two centers of excellence in Engineering in Chile through the years 2005 to 2008. Professor Rodriguez is IEEE Senior Member since 1999, and is an active associate editor of the *IEEE Power Electronics and Industrial Electronics Societies* since 2002. He has served as Guest Editor of the *IEEE Transactions on Industrial Electronics* in five opportunities (Special Section on: Matrix Converters (2002), Multilevel Inverters (2002), Modern Rectifiers (2005), High Power Drives (2007) and Predictive Control of Power Electronics Drives (2008).