

INFLUENCE OF DAYLIGHT IN URBAN DESIGN AS A TOOL TOWARDS A MORE SUSTAINABLE CITY

¹Fernández Expósito, Manuel; ¹Moreno Rangel, David; ¹Esquivias Fernández, Paula M.;

¹Group "Architecture, Heritage and Sustainability: Acoustics, Lighting, Optics and Energy". University Institute of Architecture and Building Sciences (IUACC).

University of Seville.

Avenida de la Reina Mercedes 2 41012 Sevilla, Spain

e-mail: *manuelfernandez@estudioheliopausa.com

ABSTRACT

Issues of sunlight and daylighting condition for design of the buildings has had little research and few practical applications among other things, because of the absence of national or local minimum requirements. If we focus on the urban scale, awareness and the number of papers addressing this subject is almost inexistent.

Among the principles of bioclimatic urban, some authors like José Fariña Tojo or José Manuel Naredo determine planning criteria which can be drawn basics that directly affect the urban design. First, it is essential structural roads that respond to sunlight requirements for getting optimal orientations for the maximum utilization of natural light both for the street and for buildings annexed. Besides, this road has to incorporate an appropriate vegetation to the requirements of humidity and environmental evaporation (trying to minimize thermal loads), getting all together, a urban morphology with well oriented facades and an appropriate proportion of courtyards.

The paper will analyze how most relevant urban parameters influence the sunlight inside the building, assessing this influence from the point of view of sustainability. We consider parameters of traditional urban, such as height, width of the street or orientation, such as vegetation and pavement or materiality of the facades.

As a case study, we chose a city with warm weather and between 30-40 ° latitude as Sevilla. As an example, we study a street that belong to morphology expansion district.

In conclusion, we will carry out an evaluation of the degree of influence each parameter has to improve daylighting conditions inside the building, trying to determine which ratio width and high of a street is the most optimal to achieve optimum use of daylight and therefore greater energy savings.

Keywords: Urban design, Urban parameters, Daylighting, Sunlight

1.- Introduction

For years, the Research Group TEP 130 "Architecture, Heritage and Sustainability: Acoustics, Lighting and Energy", has been working on several researches. Particularly David Moreno, Paula M. Manuel Fernández Esquivias are developing their research, among others, on the thematic daylighting in architecture and urbanism.

The first one, he did his thesis by the name "Towards an architecture for life: four actions / reactions that allow outlining the new conditions of the architectural to the problem of sustainability". The other two authors are make their doctoral thesis on daylighting, the first bringing an integrated vision of light and thermal component of the solar radiation inside the buildings and the second on the urban environment. Therefore, this paper is part of the research carried out during that doctoral thesis.

The team has studied five official master related with subject. Teaching both in the department of "History, Theory and Architectural Composition" and in the "Architectural Construction I", of the School of Architecture of Seville and with great participation in multiple research projects.

2.- Objectives

Historic cities, object of this paper, were planned following an organic or geometric design, the two orderings are present from the first cities and have been merged and even overlapped as they have been developing.

Organic order makes reference to its relationship with nature, it is composed with axial symmetry and circular or oval shape. Instead, geometric order, is governed by a rectilinear geometry with hierarchical streets and blocks of square, rectangular or semicircular shape.

The first type, the orientation of the facades is highly variable and is influenced by the streets that adapt to the slope. The buildings have a high degree of overshadowing due to the narrowness and height of buildings. For the second, the streets are hierarchized with principal axes of larger section and other minor secondary. Regularly grid oriented to the four cardinal axes, North, South, East and West, resulting in buildings with 25% of the facades in each orientation.

Along with these ancient plannings, as part of the historical process, it is generally known that there were several trends and movements among which can be highlighted the proposals for the Garden City or the City of the Modern Movement. In the first, the streets are oriented generally following the slope of the ground, predominating the layout northwest-southeast, achieving facades with good conditions of sunlight, favored by the great distance between them. In the second case, the relevant distinction between the street layout and fabric buildings. These are arranged comb-shaped perpendicular to the streets. Also, it was studied the placement of the blocks according to distance and height oriented. The heliotermios axes were used to define the orientation, preferably in north-south orientation.

Despite concerns showed by those proposals, in the late eighteenth century and during the nineteenth urban design was characterized by the lack of space and hygiene resulted in homes with very little daylighting. In the wake of this, in European cities [1] began to appear regulations requiring that the sky was seen from any window of a residential building. Furthermore, parameters such as distance between buildings or the percentage of area should illuminated were set. Current regulations require that every habitable space must be outside with ventilation and daylighting. Minimal surfaces of voids are set in relation to the useful surface area of the space.

The absence of a specific mandatory legislation, such as CTE, leaves the urban design in the hands of regulations whose awareness in urban scale is low [2].

However, it is possible to find such concern in new trends of urbanism, specifically, within the principles of bioclimatic urbanism [3] [4] there are a number of guidelines that directly affect urban design. Below are listed the most relevant that are clearly related to the purpose of this paper:

- We need to make a street layout organized that responds to criteria sunlight and wind.
- The streets must be adapted to the topography, achieving orientations that favor the sunlight and avoid unfavorable winds.
- The vegetation must be appropriate to the needs of environmental humidity and evaporation.
- Urban morphology should generate blocks with facades well oriented and an appropriate proportion of courtyards.

A street layout well oriented under the criteria of sunlight will achieve a good orientation of the facades of buildings and, consequently, good daylighting inside the building. For this first premise, it is necessary to take into account the height and distance of the surrounding buildings as they represent elements of obstruction and reflection of the potential of daylight that can enter a space [5]. Particularly in winter, when there are fewer hours of sunlight, it is necessary to know what should be the distance between two or more buildings that guarantees sunlight for the most unfavorable months, considering the position of the sun at all time. However, during the summer, urban obstructions may avoid overheating of spaces, if the external reflected light provides enough daylight, reducing input direct sunlight.

Therefore, from the point of view of bioclimatic urbanism, the research aims to analyze the influence of the most important parameters on the conditions of daylighting inside the building.

3. Methodology and case study

3.1.- Methodology

As a starting point for achieving an appropriate design daylight in urban areas and inside the building, it should be taken into account several aspects [6]. It is very important the influence of the place, orientation or shape and dimensions of the building, to take advantage of daylight supply and prevent disadvantages to the presence of the sun and its movement. Daylight should be considered from the distribution stage of location: obstacles surrounding a building can have an impact on both the amount of light in the voids and the distribution of light inside a space.

To analyze how urban parameters influence daylight conditions inside the building, we study the reflected light that occurs in all exterior surfaces, which is one component of Daylight Factor. This is defined as the ratio of the light level obtained on an inner horizontal surface respect to the one obtained in that area if it were located outside without any obstruction. For the calculation of Daylight Factor only it is considered the diffuse component of daylight, so it does not consider the presence of the sun, being used Overcast Sky Model approved by the CIE (Commission Internationale de l'Eclairage) distribution of luminance of the sky commonly used for calculation. The daylight factor (fig.1) anywhere on a work plane can be expressed as the addition of three components: the light coming directly from heaven (sky component -SC), the reflected light on the outer surfaces (external reflected component -ERC) and the reflected light on the inner surfaces (internal reflected component -IRC).

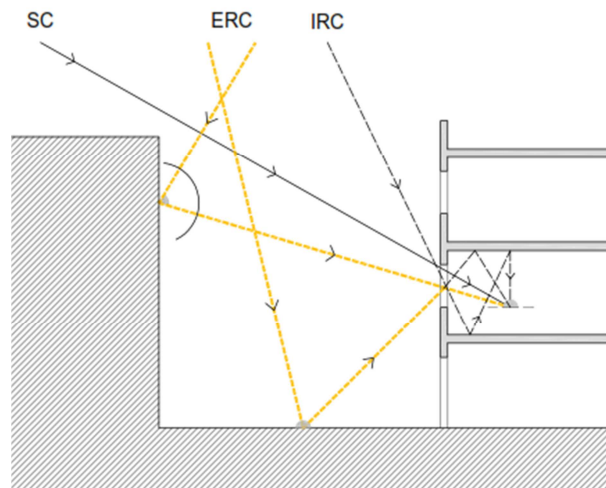

Fig. 1 "Daylight Factor". Source: the author

Its formula is:

$$DF (\%) = SC (\%) + ERC (\%) + IRC (\%) \quad (1)$$

If the lighting requirements need an appearance of daylighting predominantly, then DF must be equal or greater than 5% [7] in which case the use of artificial lighting would not be necessary:

- DF < 1%, low daylight
- DF < 3%, regular daylight for activities poor accuracy during most of the day
- DF < 5%, good daylight for precise activities for several hours a day
- DF > 5%, very good daylight for precise activities for many hours a day

For the analysis in this study, it was calculated using the Advanced Software Autodesk ECOTECH. This program calculates the DF by Split-Flux method developed by the Building Research Establishment (BRE) in the UK. This method calculates the DF of a point as the sum of the direct and reflected, exterior and interior components of daylight. Each component is calculated separately and then summed to obtain the overall lighting in the calculation point.

This method distributes all incident light in a window in two directions, where the luminous flux upwardly and below the window is divided into two components. Each of these components is reflected based on the weighted average reflectance of the surfaces above and below the window. This type of calculation works best in rooms where the ratio of the width, depth and height is 1:1:1, a unusual situation, so that calculations with this method usually results in results major inaccuracy.

In the version of this method implemented in Ecotect a ray tracing is run, each ray represents approximately the same solid angle of sky. The program requires a sky design value which is derived from a statistical analysis of external illuminance levels, representing the horizontal illuminance level that 85% of the time is exceeded between 9h. and 17h. throughout all year. The internal reflected component is determined by an equation using the weighted average of the reflectance of internal surfaces, the total area of glazing and a correction factor for external obstructions.

This program, among others, has been tested by the research group under which this article is written (Research Group TEP 130 is inscribed: "Architecture, Heritage and Sustainability: Acoustics, Lighting, Optics and Energy" University Institute of Architecture and Sciences. Construction of the University of Seville), with an important endorsement in the reliability of the results.

3.2.- Case study

As a case analysis, we do not choose a specific city, but a characterization of common parameters: warm climate and latitude between 30° and 40°. Urban morphology that defines some of these cities is identified with different homogeneous areas [8] [9] [10] and types of street, such as the old towns, orthogonal extensions, expansion district and polygons of housing blocks. This paper focuses on the characteristics of expansion district. This planning, formed in the second half of the nineteenth century and the first of the twentieth century, is composed by a hierarchical grid with streets that cross orthogonally. The length and width of streets are uniform and usually vary between 80 and 200 m and 10 to 50m. The ratio height and width of the sections varies between 0.7 and 1.7 (fig.2).

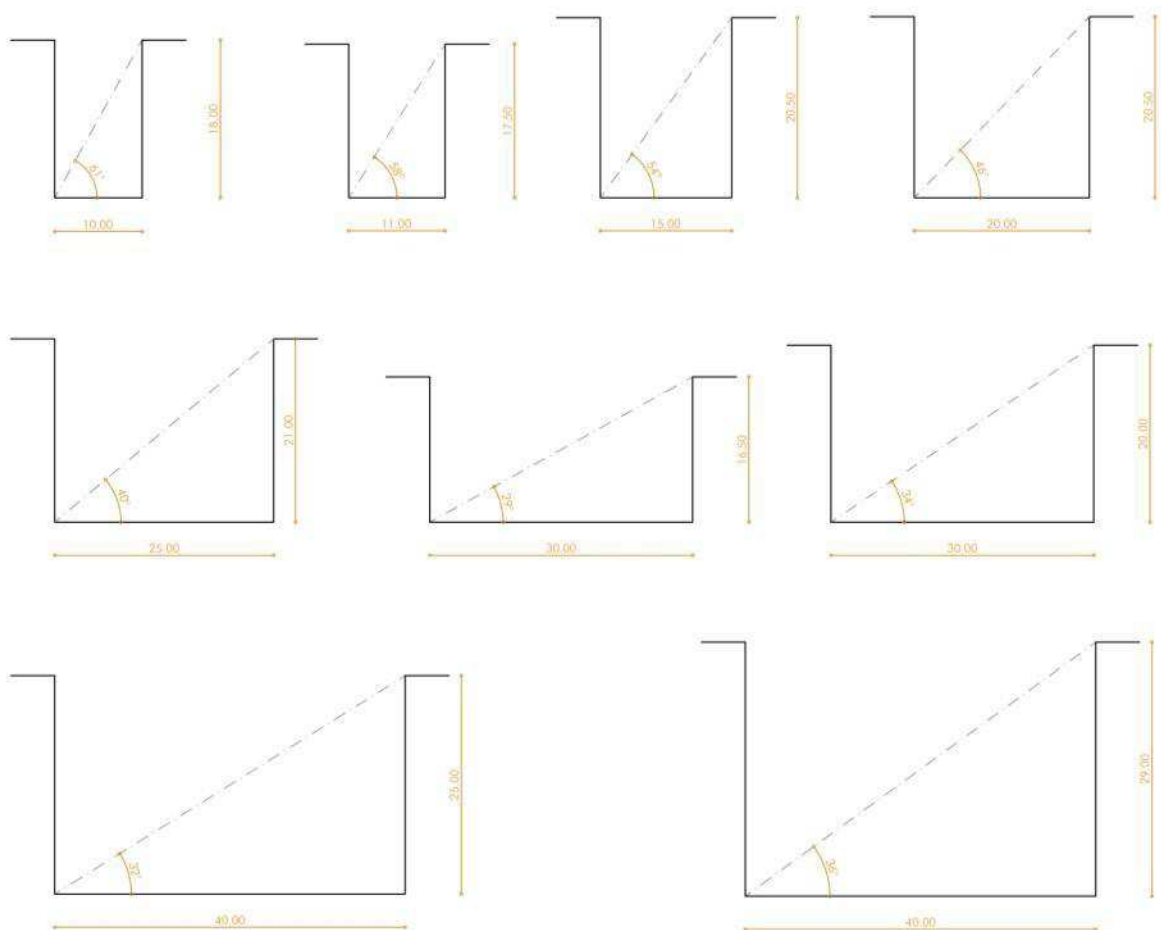

Fig. 2. "Examples of street sections of study." Source: the author

With little climate adaptation, public spaces are protected from the harsh climate in summer by trees. Length-straightness of the streets and width-height of the buildings combine one unfortunate orientation that may lead to unfavorable winds. The amplitude and regularity of the streets determine the regularity of the shapes and size of blocks, considerably square and approximately one hectare surface. The characteristic buildings are multi-family flats with four to ten floors.

The space analysis (fig.3) is a room of 20m² (dimensions 4x5x3m) dedicated to rest and development activities at work or reading. A work plane is set at 85 cm from floor where the influence of external reflected component is analyzed through a standard void 1.5mx2.10m at ground with aluminum frames and double glazing 4+6+4mm low emissivity.

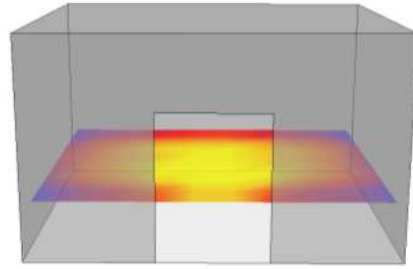

Fig. 3 "Area of study of the building" Source: the author

The urban area corresponds to one of the representative models of this type of planning (fig.4). Space is disposed at the main facade of a dwelling on the first floor (level + 3.00m).

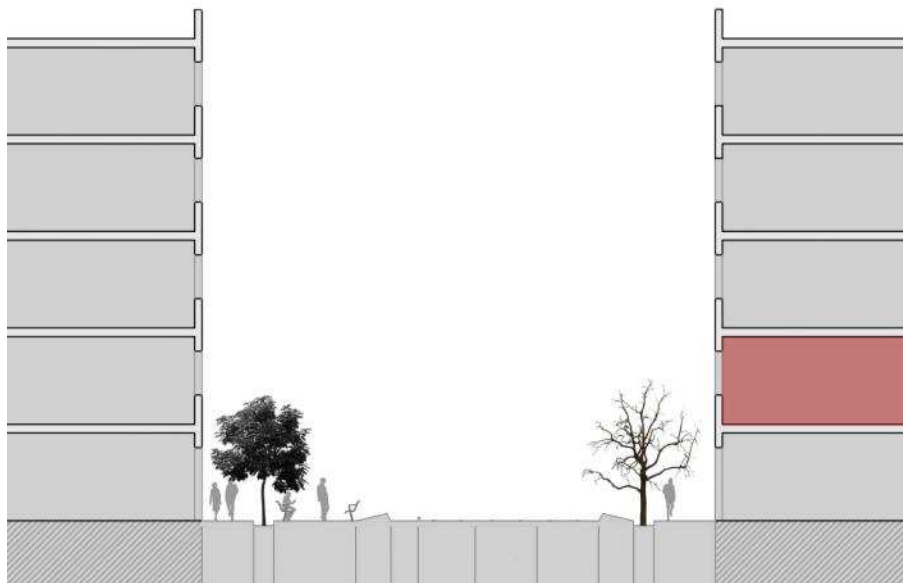

Fig. 4 "Urban area of study." Source: the author

For this study we propose the following urban structure in terms of the parameters which affect the external reflected component (fig.5):

- Length of road: 200m set as a fixed value for all simulations.
- Height of building and road width: three scenarios will be studied for a road width of 18,00m; 12,00m; 18,00m; 24,00m. 0,65-1,00-1,30 resulting ratios respectively.
- Materials: the facade is brick and owns 20% of glazed surface. The holes have aluminum frames and double glazing.
- Vegetation: there are deciduous trees each 12,00m.

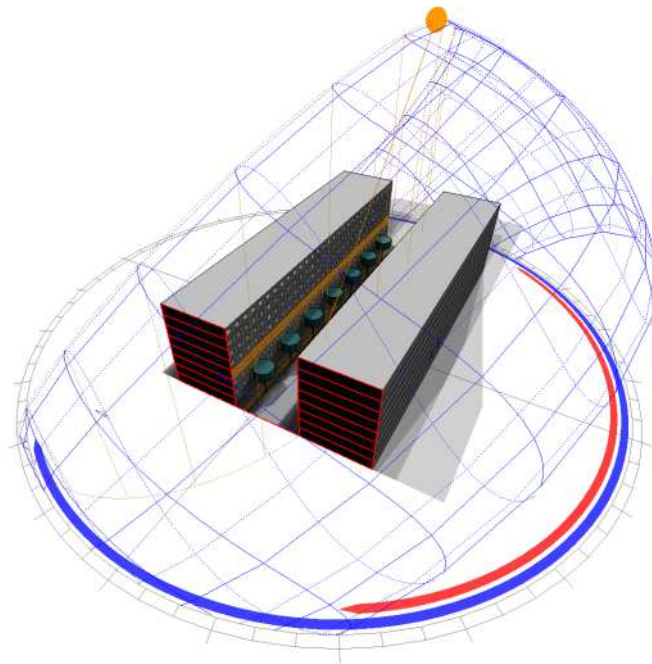

Fig. 5 "model calculation". Source: the author

4.- Results

Next, the calculation results of the reflected component external and lux level (Table 1 and 2) obtained by the study of variation of the ratio between the width and height and with or without the presence of vegetation are shown.

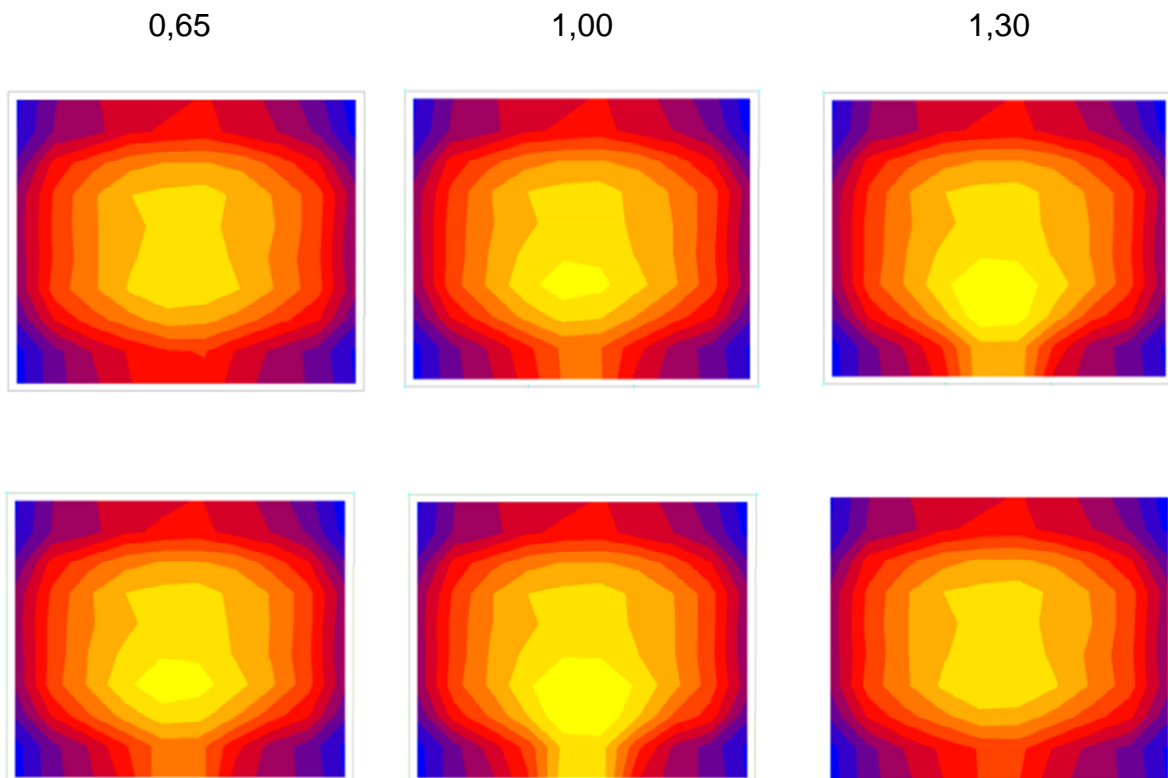

Table 1 "Diagrams of external reflected component"



Tabla 2 "Diagramsof level lux"

Next, we show the table of the most relevant results obtained with and without the presence of vegetation (Table 2 and 3):

Ratio (h/a)	ERC _{min} (%)	ERC _{average} (%)	ERC _{max} (%)	E _{min} (lux)	E _{average} (lux)	E _{max} (lux)
0,65	2,37	4,21	7,40	112,62	263,63	1844,66
1,00	2,37	4,89	7,81	102,62	246,82	1807,73
1,30	2,37	5,42	7,90	93,41	177,49	1656,64

Table 2 "Results with vegetation"

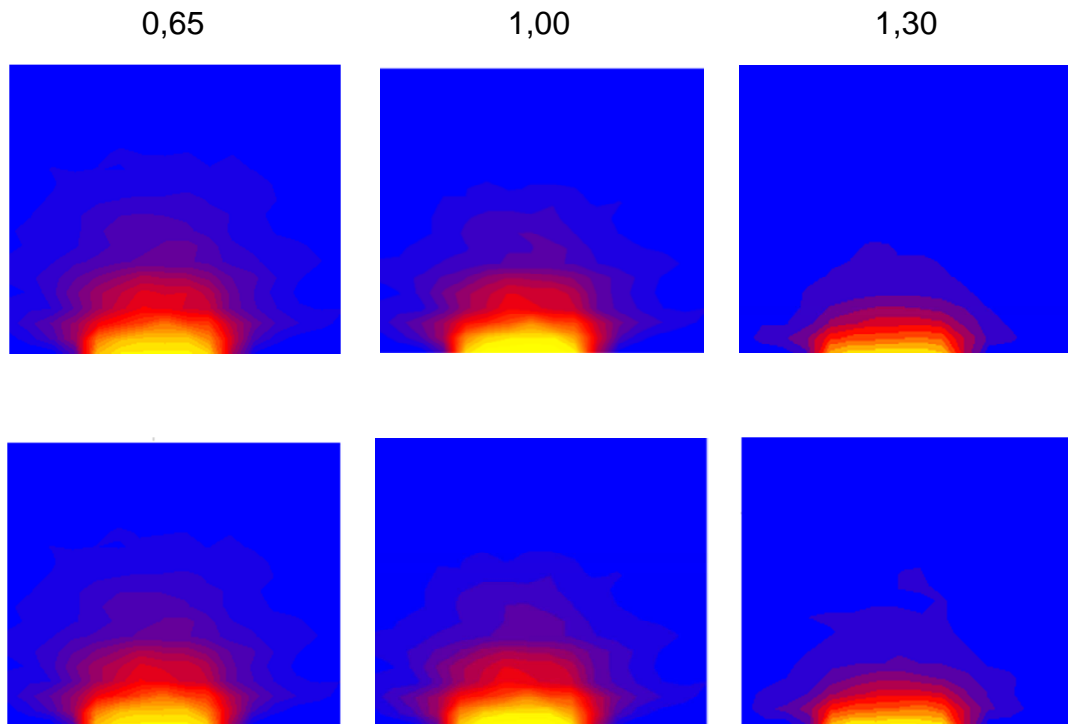
Ratio (h/a)	ERC _{min} (%)	ERC _{average} (%)	ERC _{max} (%)	E _{min} (lux)	E _{average} (lux)	E _{max} (lux)
0,65	2,38	5,24	7,46	105,62	261,08	2224,33
1,00	2,38	5,74	7,88	105,56	244,33	2169,51
1,30	2,38	6,02	8,40	101,56	173,77	2126,29

Table 3 "Results without vegetation"

In view of the results and to compare both studies, we performed the following graph (Table 4) depending on the height of the building and the average value of percentage of external reflected component, so that appreciable variation is occurring. The hypothesis 1 corresponds to the calculation of external reflected

component with presence of vegetation, while the hipótesis 2 corresponds to the calculation without presence of vegetation.

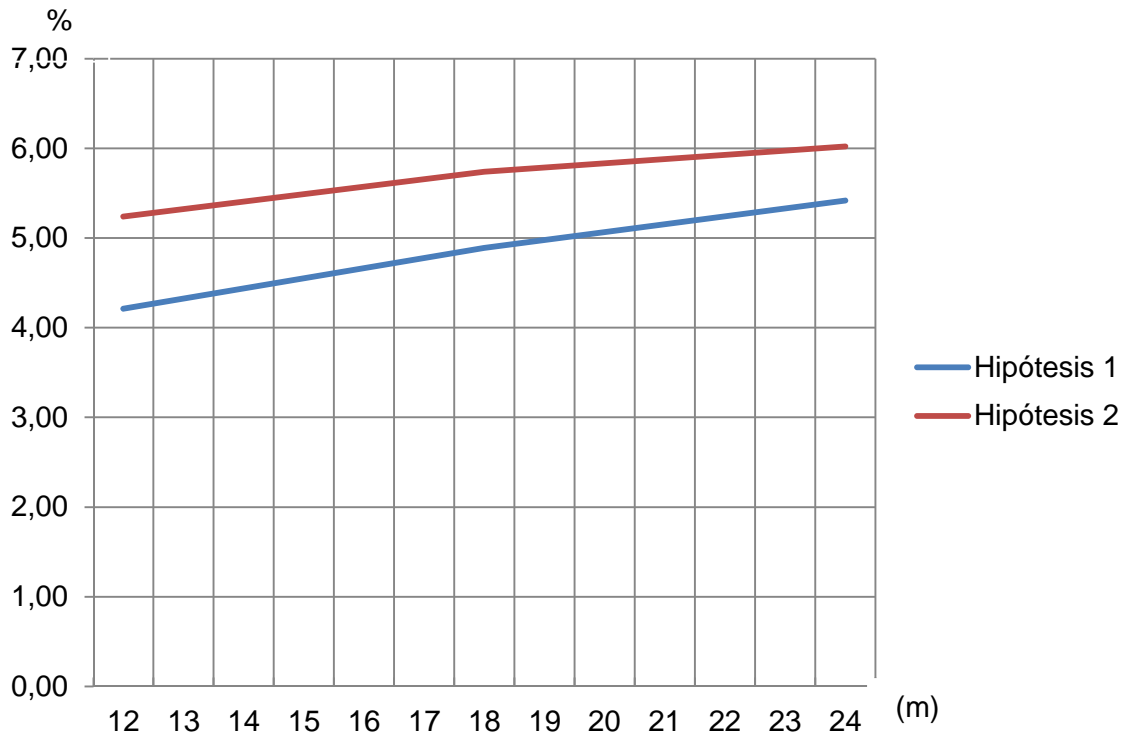

Table 4 " Comparison of calculation hypothesis "

5.- Conclusions

After analyzing the results, several conclusions are obtained. First, the external reflected component is clearly increased in relation to the height of the building. As can be seen in the values in the graph, when we double the height of the building is increased by more than 1%. In this way, it is sufficient to contribute to keep value of daylight factor around 5%, which allows a good daylighting for the development of any task. On the contrary, excessive height damages the level of daylighting within the space, obtaining an average value of 177.49 lux, that is not sufficient for the development of specific tasks.

Therefore, for this case, the height-width ratio should be close to 1.00 since the daylight is close 300 lux. Besides, the external reflected component will approximate 5%. All together with sky component and internal reflected component will achieve a suitable daylight factor.

In the case of the presence of vegetation, the graph shows the percentage reduction of external reflected component. This may be because the vegetation obstructs part facade and pavement surface favoring greater reflection. In the case of the illuminance, hardly is disturbed since trees are medium sized with height similar to the first floor. That supports the idea of using species of deciduous trees, since during the winter may lose their foliage allowing reflection occurs at the maximum surface of walls and pavement, which favors a higher percentage of daylight factor supplemented with the weaker solar radiation that occurs during those months. During summer, the opposite situation occurs, the tree mass will decrease the reflected external component, but being the period of greatest radiation, it will achieve good lighting comfort inside the building.

As a final conclusion, it can be determined that for the case of urban area studied, the ratio width and height of street should be close to 1 for a suitable degree of daylighting. The use of adequate vegetation, deciduous tree can be very favorable and serve as lighting controller. Vegetation will shade on the street and may be used as hindering element to prevent overreflection.

Consequently, we can see that the urban parameters studied have a high degree of influence on the daylight conditions inside the building. So far, urban planning, has established ratio height and width for the urban design of any street, but it is demonstrated that this is not enough. For this case, it is necessary to consider many other factors if you want to achieve an adequate urban design and degree of daylighting comfort. Parameters such as vegetation or materiality of facades and floors should be unavoidable for the early approaches to urban design.

The close relation that occurs between urban space and building, between exterior and interior, should be treated with special sensitivity, analyzing each of the components that improve or harm that relation. A perfect harmony between them derives both urban design of high environmental quality and an interior space with the right degree of daylighting. This leads to a better use of daylight and therefore greater energy savings. Furthermore, in a bright space that ensures visual efficiency, sensorial comfort and an appropriate environment, people can do their work faster and with good accuracy, consequently, they will achieve higher productivity in the development of these tasks.

REFERENCES

- [1] Yáñez Parareda, Guillermo. Solar architecture and natural lighting: concepts, methods and examples. Madrid: Munila-Lería; 2008.
- [2] Higuera García, Esther. Urban planning and environment. Madrid: Institute of Juan de Herrera; 2001.
- [3] Olgyay, Víctor. Architecture and Climate: bioclimatic design manual for architects and urban planners. Gustavo Gili; 2004
- [4] Cárdenas Jirón, Luz. Characterization of bioclimatic parameters in urban fabric residential. Urban Research Notebook No. 82; 2012
- [5] Michele Morganti, Helena Coch Roura, Carlo Cecere. The effect of urban obstructions in mediterranean climates: built form typology, density and energy. ACE: Architecture, City and Environment ; 2012, Año 7, núm. 19 Junio. P. 13-26
- [6] Fariña Tojo, Jose. Bioclimatic Urban Design Manual, Manual of recommendations for the development of planning regulations; 2013.
- [7] Spanish Lighting Committee. Technical Guide for the use of natural light in the lighting of buildings / Spanish Lighting Committee, Institute for Energy Diversification and Saving of Energy, [in collaboration with the Superior Council of Colleges of Architects of Spain]. Madrid: IDAE; 2005.
- [8] Spain. Directorate General of Housing, Architecture and Urbanism. Recommendations for the project and design of urban road / Directorate General of Housing, Architecture and Urbanism. Madrid Directorate General of Housing, Architecture and Urbanism; 2000.
- [9] Chueca Goitia, Fernando. Brief history of urbanism. Madrid: Alizana; 2011.
- [10] Cano Forrat, Juan. Introduction to the history of urbanism. Valencia: Editorial UPV, DL .; 2003.
- [11] Material Library ECOTECH, software analysis and energy simulation of buildings.