

MEDIRECT: A First User Experiment

E. Ramos (*), J. Pinilla (*), A. Torralba (**) and L.G. Franquelo (**)

(*) SAINCO I+D C/ Tamarguillo ,29. 41006 Sevilla, España

tfno: +34 5 492 0992 fax: +34 5 492 3921

(**) Dpto. Ingeniería Electrónica, Escuela Superior Ingenieros. Universidad de Sevilla

Avda Reina Mercedes s/n. 41012 Sevilla, España

tfno: +34 5 4556878 fax: +34 5 4556849

Abstract: *This paper presents MEDIRECT, a FUSE experiment for accurate measurement of the quality of service in power systems using DSP's.*

1. INTRODUCTION

One of SAINCO's core activities is the design and development of systems for the automation and control market, within the electrical energy distribution industry.

The proliferation of connected non-linear loads on electrical networks with an increasingly larger harmonic contents, together with wave quality and network supply problems, require more and more efficient measurement and control elements to be able to adapt to these new requirements.

The immediate objective of SAINCO in this project was to be acquainted with and to incorporate Digital Signal Processing (DSP) in the design process.

In order to fulfil this objective, SAINCO proposed an application experiment to FUSE action in ESPRIT program which has been granted with a positive recommendation for funding.

The Dpto. de Ingeniería Electrónica at the Escuela Superior de Ingenieros de Sevilla, acts a support group providing expertise in DSP technology.

The application experiment consists of incorporation of DSP technologies in the company Remote Terminal Units (RTU) in order to implement the measurement of electric power system magnitudes such as voltage, current, power, energy, etc. with the object of concentrating the functionality

which until now has been carried out by SAINCO's converter racks and conventional RTU analogue acquisition cards on a single acquisition card incorporating DSP hardware and software techniques. Also contemplated are quality of measurement (response to non pure sinewave signals) and other functions traditionally associated to external devices (quality meters, frequency meters, etc.). Usually the existing measurement equipment is based on a set of devices comprising:

- Transformers (voltage and current coupled to medium and high voltage lines).
- Converters (for voltages, currents and power).
- Cards (metering, A/D, others for general purpose and communications).
- Output (to other devices).

This kind of system is specially conceived to guarantee a correct response at frequencies near 50 Hz, although the measurements may become distorted when frequencies increase: core saturation begins, the influences of strays begin to appear, etc.

So, the system conception is based on the assumption that voltage and current signals are practically pure, 50 Hz or 60 Hz sinewaves. The new kinds of load produce currents with frequencies that differ from the nominal, whereby the measurement sequences based on the conventional techniques are imprecise at frequencies other than the nominal one. The

measurement system must be modified and optimised in order to encompass a wider range of frequencies.

The device developed by SAINCO consists on an analogue acquisition card which incorporates DSP capacity for the voltage and current processing together with a general purpose microprocessor for the storage and communication control.

This module has an input capacity for three voltages -Ur, Us and Ut- and three currents -Ir, Is and It- received directly from the voltage and current measurement transformers of a polyphase installation, so a single card integrates what is normally implemented on a chassis fitted with several converters and specific electronic modules. This solution offers better performance in terms of precision, enhanced functionality and lower prices thanks to a reduction in the number of elements.

Schematic representation:

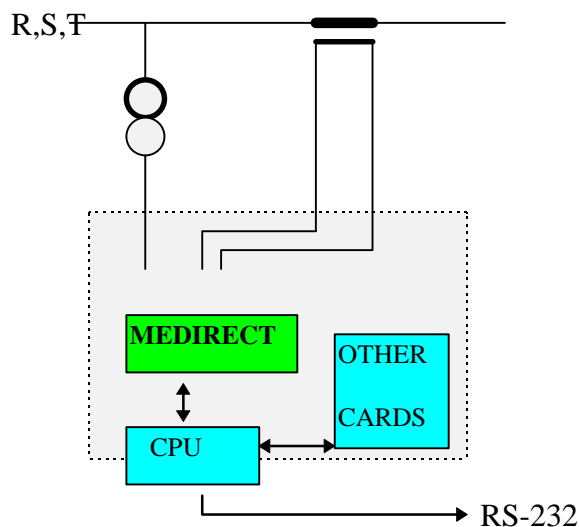

Fig. 1.SAINCO-RTU

The use of DSP technology in electrical measurements offers some major benefits:

- * It solves the problems of measuring in a wide spectrum of frequencies, providing a true R.M.S. values (not average values) with a better precision.

- * It provides information on signal distortion, thanks to the application of FFT techniques.

- * It represents a significant simplification of the measurement sequence by blending the sensing device and providing digital output to the other devices that make up the installation.

- * It constitutes an economically profitable solution by concentrating the functions of various devices that are currently installed separately, given the difference between their operating techniques (voltmeter, wattmeter, frequency meter,...), in a single unit.

The current falling price tendency and the growing performance of DSP devices, together with the proliferation of manufacturers that offer increasingly efficient versions, all point to the fact that the use of these technologies in application companies like SAINCO is essential in order to maintain a competitive edge against American and Southeast Asian manufactures that offer high performance at very competitive prices.

This know-how will enable SAINCO to engage in the development of other products using this technology, such as control devices for airport meteorology supervision, environment data acquisition, water cycle management,...and let us to go on with our beyond frontier strategy (over the last five years, SAINCO has supplied the Utility Industry with approximately 1000 RTU's, of which 20% has been exported to the USA and Latin American countries).

2. GENERAL DESCRIPTION

The direct analogue input module MEDIRECT is formed with the same structure as SAITEL family (registered by SAINCO), i.e., with a control head implemented with a general purpose microprocessor (68HC11) and a specific card depending on the model.

MEDIRECT will be able to read directly from the measurement transformers and to obtain the electric magnitudes. The result of the process will be transmitted to the higher hierarchy levels of the system.

Basically, the magnitudes to obtain are:

- Voltage and current R.M.S.
- Active and reactive power
- Active and reactive energy
- Power factors

These magnitudes are actualised at a rate of no less than one per second.

The module is independent of the nominal frequency and will be able to work both 50Hz or 60Hz, without any change in software (see fig. 1).

3. HARDWARE DESCRIPTION

Hardware architecture is based on a dedicated DSP microprocessor for the acquisition and processing functions which is connected by an synchronous serial interface to the control head module. The different parts to be considered are (see fig. 2):

- Analogue inputs.
- A/D conversion. Self calibration.
- Digital signal processing
- Control head interface
- Supply and communications
- Mechanical format

-Analogue inputs:

This module has six (6) bipolar analogue inputs that come in from the auxiliary rack of adaptation: really three (3) come from voltage measurement transformers and the others three (3) from current measurement transformers.

The maximum range in voltage is (+-)2.5V, that will corresponds to 250% nominal value for current inputs and to 133% for the voltage inputs.

Analogue Inputs

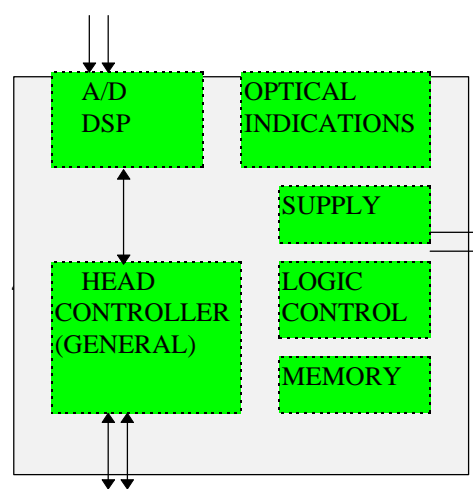

RS-232 Communications

fig. 2.

The analogue input are protected in concordance with the best industrial practice in electromagnetic compatibility.

-A/D conversion:

The analogue inputs are multiplexed and converted with a 12 bits of resolution at a sample rate of 20 kHz.

A self calibration is included with high precision references.

-Digital signal processing:

The process core is formed by a DSP microprocessor that carry out the conversion control and the mathematical calculus to obtain the different electrical magnitudes by FFT algorithms, and to communicate with control head too. This process consists basically on a 64 points Cooley-Tukey Radix-2 DIF FFT with a 20ms period for every one of the six analogue inputs. The program resides in external EPROM to be modified when need it.

-Interfaces:

The interface between DSP and control head is a synchronous serial interface (SPI). The interface with external higher modules are with a standard RS-232.

-Mechanical format:

MEDIRECT has the same format as RTU family, single eurocard format (160mm * 100mm).

The input/output communications and signals is through a standard DIN41612 type F connector, and the interface with the control head module is through a standard DIN41612 C/2 vertical female connector.

4 SOFTWARE DESCRIPTION

Samples are read directly from converter (AD7892-1) through a 12 bits data bus and are stored in a data memory position.

There are 64 samples per cycle for every one of the six analogue inputs with a delay between each two of 6 microseconds approximately. The DSP processor will be interrupted every 8 conversions and compute a 64 point Fast Fourier Transform for each channel with the following characteristics:

- Simple FFT butterfly.
- Real data input.
- Scale values for overflows prevention.
- Normalization.

The control software is splitted in two parts:

- Adjustment.
- Measurement

The adjustment part ascertains the offset of the linear input amplifier and the A/D conversion result when 0 volts are applied to the inputs pins. During measuring this offset has to be subtracted from each sample to get correct results.

The measuring process for power is as follows: during a constant measuring period all pairs of voltage and current samples are multiplied together and added.

This result represents a value which is proportional to $V \cdot I \cdot \cos(\mathbf{j})$. Note that the period $1/f$ must not be a integer multiplier of the sampling interval to avoid aliasing effects.

Simplified flowchart:

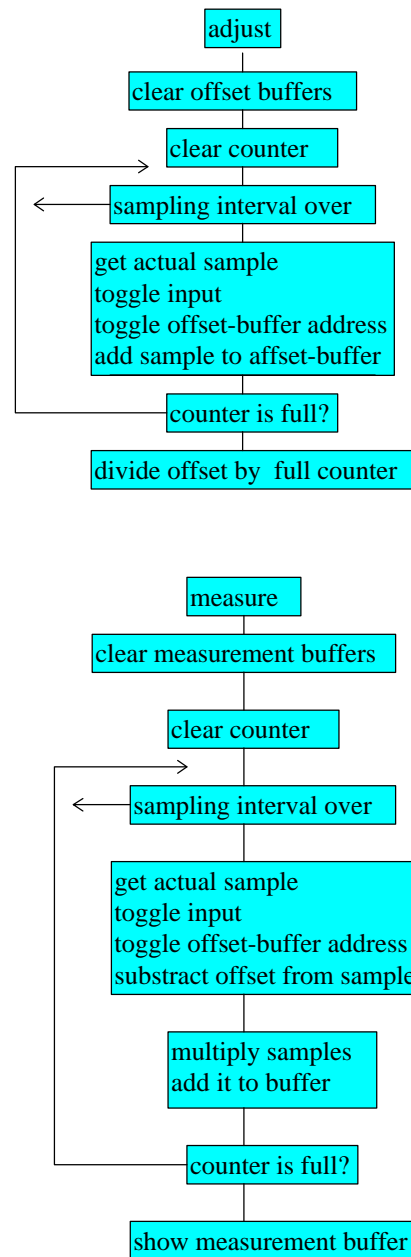

5. CONCLUSIONS

Current falling prices and growing performances of DSP's make them attractive for solving a large number of problems in power systems measurement and control, one of the main activities of SAINCO. to acquire the technology in a real problem, a FUSE experiment, called MEDIRECT, has been described.