

Forma 15

Agent Based Modeling

#forma15 #netlogo #processing

Edited by Culturadigital, May 2016

<http://forma.culturadigital.cc>

info@culturadigital.cc

[@cultdigit](#)

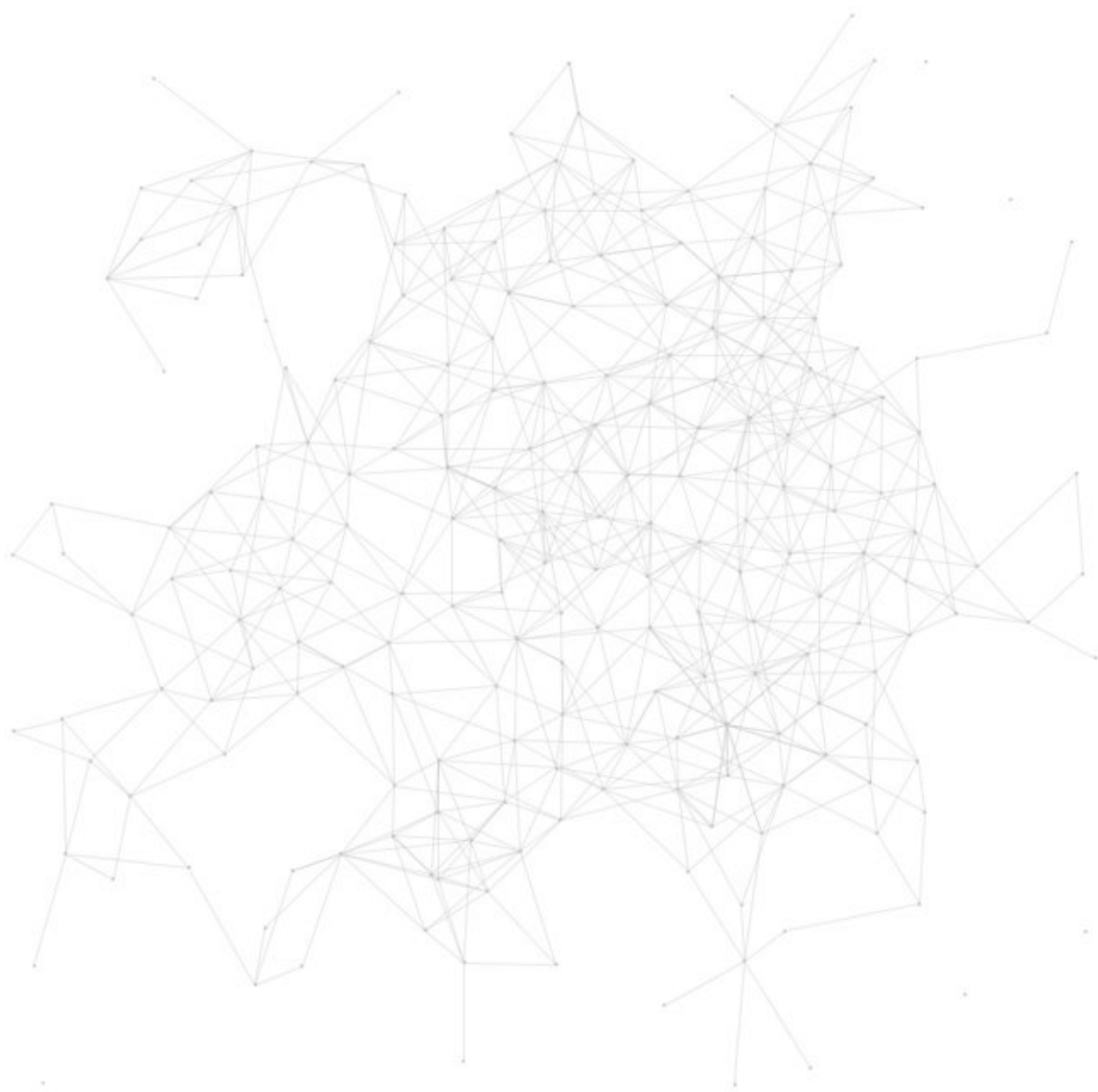

I. The Workshop

WHAT IS FORMA?

FORMA is an initiative to promote agent-based thinking among researchers from every single discipline such as art, biology, maths, sociology, economics and urbanism. Agent-based systems are used to study complex realities, which can hardly be shaped by traditional methods. The aim of this special event is therefore, to provide participants with a solid agent-based modelling expertise that will enhance their understanding of complex processes within their field of research.

The workshop is organized around a limited number of case studies, selected among proposals submitted by researchers from all over Spain. Each case study has a clear target to be addressed during the three full-days of the event, and the authors of the proposal are assigned an agent-based modelling expert plus a team of students, typically from Computer Science and Mathematics, that are in the process of developing modelling skills.

Forma provides an interdisciplinary space where students can work together to solve real problems, while researchers from any field meet the opportunity to work hand in hand with highly skilled programmers towards their research targets. This event unfolds as a great networking tool, where minds with different assets meet to pursue common interests. After this first edition, many of the teams have continued developing their models, or established other kinds of collaboration, even sending abstracts together for international conferences etc.

Apart from the "hands-on" work, the workshop includes top level speakers from the University of Seville, as well as daily tutorials on "soft-learning-curve" languages for agent-based modelling, such as NetLogo, and also Processing. Researchers with no previous knowledge of these tools, will develop enough understanding to prototype new case studies in the future through agent-based modelling, even if only conceptually.

OPEN CALL AND SELECTION PROCESS

In this second edition, a total of ten proposals were received, from which a total of seven were selected, leaving out only three proposals that were too broad for the scope of the workshop or not aimed at agent based systems.

The communication strategy of the open call for proposals, being the second edition of FORMA, was mainly channelled via mailing lists of the major universities in Andalucí and other important universities in Spain. Four of the selected proposals had some connection to the University of Seville, followed by Madrid (2), University of Cadiz (1) and Central University of Ecuador (1).

Other digital channels like twitter were used intensively to spread the call for proposals and participants.

SELECTION CRITERIA FOR CASE STUDIES

FORMA is targeted towards studying complex processes by means of agent-based modelling. The criteria followed during the selection of case studies in this first edition have been:

- **Contemporary subjects:** The case study shall address a topic along the lines of the new information paradigm, digital societies, technological advances and other subjects in which network behaviour plays a decisive role.
- **Complex processes:** Models should aim to clarify a well-defined phenomenon, which due to its inherent complexity requires advanced computational techniques and an interdisciplinary approach.
- **Spatial interaction:** The workshop targets the study of complex processes in which spatiality, be it literal or abstract, has a strong influence over the behaviour of the system at play.
- **Visual understanding:** Proposals shall request for results that can be directly communicated through a graphic visualization of the model and be easily understood by all audiences.
- **Clear identification of the problem:** Because of the limited time to develop the models during the workshop, it is fundamental that a key question is clearly identified in the author's proposal.

CASE STUDIES SELECTED

N1. Genetic Algorithm for Close Range Photogrammetric Network Design

Correspondance author: Elena Cabrera Revuelta

N2. Curves of pursuit

Correspondance author: Juan Carlos García Vázquez

N3. Fill the Gap[s]: Digital simulation to face the post-bubble challenge

Correspondance author: Juan Francisco Fernández Rodríguez

N4. The Monetary System as a Cause of Economic Bankruptcy. The "Sovereign Money" Solution

Correspondance author: Jesús Manuel Utrilla Trinidad

N5. Evolutive patterns in island colonization processes

Correspondance author: Javier Fernández López

N6. Recovering of 24 May Avenue in the historical center of Quito

Correspondance author: Pedro Almagro Blanco

N7. Effectiveness of Shares Capacity Discover Through: Coaching-Learning Method Consolidation

Correspondance author: Ana María Orti González

V2. Maritime trade Cadiz. 1810-1812

Correspondance author: Luis López Molina

*N=NetLogo, P=Processing

TEAMS & ORGANIZATION

Once the case studies were selected, one month prior to the workshop, a brief documentation explaining each proposal was uploaded to the website. Then, all participants were invited to fill in a form via email indicating three of the selected case studies ordered by preference, and also, a short note on their background. With that information the organization distributed the participants in teams of 4 to 8 members per team, and assigned a modelling assistant to each one of them as well. Every participant was informed of the team they had been assigned to beforehand.

The workshop opened on Wednesday 25th November, 5.00 pm with a short introduction. Then followed a lecture by Joaquín Borrego Díaz introducing agent based modeling. And finally, a round of ten-minute presentations of all the proposals, carried out by their respective authors.

Next day kicked off at 9.00 am with a lecture by Fernando Sancho Caparrini, suggesting the ODD(SEA) protocol as a means to create a common understanding between researchers and technical modelling experts. Afterwards, teams started working on their proposals until evening, first addressing the main features of the model on a conceptual level, and then outlining the structure of the code itself (teams were asked to write an ODD(SEA) protocol and to design work-flow diagrams of their models before actually coding them). Modeling assistants had the task to lead and work hand in hand with all team members. Directors performed individual desk-critics with all teams throughout the day. During the first half of the day, there were two parallel programming sessions of two hours each, to introduce Processing and NetLogo to those participants who had no previous experience with either of the two languages.

The third day, Friday 27th, opened with another (morning) lecture by Fernando Sancho Caparrini, looking into real applications of agent based modeling. The rest of the day unfolded quite like Thursday, including the two-hour programming sessions, working in teams (now focusing on code development) and desk-critics.

Finally, on Saturday 25th, there were two last lectures by David Solís Martín and Irene Luque Martín focused on past experiences related to Agent-Based Modeling. Afterwards, all teams presented the results of their models throughout the morning, and by the end of the last presentation there was a discussion session and debate which marked the end of FORMA15.

CREDITS

Organized by:

- Culturadigital
<http://culturadigital.cc>
- Chair of Computer Science and Artificial Intelligence, Universidad de Sevilla
<http://www.cs.us.es>

Collaborators:

- Chair of Information Technology, Universidad de Huelva
<http://www.uhu.es/dti/>

Support:

- Lógica Computacional para la Ciencia del Dato. TIN2013- 41086-P
(Ministerio de Economía y Competitividad), co-financiado con fondos FEDER
- Fidetia



· CULTURADIGITAL ·



LOGICA COMPUTACION
AL PARALACIE
NCIA DEL DATO
TIN2013-41086-P



Directors:

- Joaquín Borrego Díaz. Chair of Computer Science and Artificial Intelligence, Universidad de Sevilla
- Fernando Sancho Caparrini. Chair of Computer Science and Artificial Intelligence, Universidad de Sevilla
- Gonzalo A. Aranda Corral. Chair of Information Technology, Universidad de Huelva

Coordination:

- Jaime de Miguel Rodríguez
- Ismael Domínguez Sánchez de la Blanca

Modeling assistants:

- Juan Galán Páez
- David Solís Martín
- Yago Fernández Rodríguez
- Irene Luque Martín
- Angel Linares García
- Gabriel Muñoz Ríos
- Javier Fernández López
- José Manuel Camacho Sosa
- Pedro Almagro Blanco
- Alfonso Manuel Orta Rodríguez
- Jesús Manuel Rodríguez Mazo

Graphic design:

- Javier Aldarias Chinchilla

Special thanks:

To all the persons not listed above, involved in the coordination of the event, and to all participants, especially students, whose enthusiasm and commitment gave life to the second edition of this workshop.

PARTICIPANTS

- Lorena Caballero Real
- Manuel Caballero Sanchez
- Laura Calzada Infante
- Yago Fernandez Rodriguez
- Juan Carlos Manjon Velazquez
- Elena Cabrera Revuelta
- Jose Antonio Barrera Vera
- Maria Jose Chavez de Diego
- Felix Martin Lopez
- Juan Carlos Carrasco Zambrano
- Jaime de Miguel Rodriguez
- Jose Manuel Jarana Exposito
- Angeles Linares Garcia
- Antonio Manuel Nunez Dominguez
- Miriam Romero Sanchez
- Juan Carlos Garcia Vazquez
- Juan Francisco Fernandez Rodriguez
- Irene Luque Martin
- Carlos Jimenez Cobano
- Alfonso Manuel Orta Rodriguez
- Andres Fernandez Garcia
- Jesus Manuel Utrilla Trinidad
- Juan Galan Paez
- Adrian Bretones Moreno
- Sebastian Lozano
- Antonio Paredes-Moreno
- Rafael Arroyo Aleman
- Javier Fernandez-Lopez
- M^a Teresa Telleria
- Margarita Duenas
- Maripaz Martin
- Jesus Manuel Rodriguez Mazo
- Diego Alonso Cancillo
- Rafael Escudero Lirio
- Ismael Huertas Fernandez
- Ivan Medina Carranco
- Pedro Almagro Blanco
- Elizabeth Regalado Bolanos
- Cristian Naranjo
- Ruben Tavora
- Fredy Caisaguano
- Francisco Javier Solis
- Paulina Teran
- Gonzalo A. Aranda Corral
- Noelia Garcia Estevez
- David Posada Mena
- Jorge Canas Estevez
- Juan D. Morillo Reina
- Ana Maria Orti Gonzalez
- Gabriel Munoz Rios
- Jose Manuel Camacho Sosa
- Ismael Dominguez Sanchez
- Luis Lopez Molina





II. Results

GENETIC ALGORITHM FOR CLOSE RANGE PHOTOGRAMMETRIC NETWORK DESIGN

Which one is the minimum set of points of view from which is possible to visualize a building in a successful way from its exterior side?

Authors:

Elena Cabrera Revuelta
ecabrera2@us.es
Jose Antonio Barrera Vera
barrera@us.es
Maria Jose Chavez de Diego
mjchavez@us.es
Felix Martin Lopez
felix_ml@hotmail.com

Collaborators:

Lorena Caballero Real
Manuel Caballero Sanchez
Laura Calzada Infante
Yago Fernandez Rodriguez
Juan Carlos Manjon Velazquez

Brief:

The term of Architectural Survey, in the field of Architecture and Heritage, includes the necessary operations, measures and analyses to understand and keep record of an architectural object in its whole configuration, including graphic documentation.

Photogrammetry is a technique that allows, through photography, getting three dimensional models of real objects, which have as sufficient metric validity to generate graphic documentation from them: plans, elevations, sections... Other instruments that can be used are total stations or scanners laser.

In this sense, an investigation has been started in order to find the minimum number of positions from which take pictures, using a Genetic Algorithm. In other words, the objective of the Genetic Algorithm is to find a set of points to guard all the facades of a building from its exterior side, in order to ensure that applying the algorithm, the data collection for the architectural survey is going to be satisfactory.

In the model that has been designed, the user can introduce the shape of the building of which there is any interest of having graphical documentation. Also, the user can adjust the technical features of the instrument that is going to be used, as the minimum and maximum distance in which the instrument works correctly.

Once the user has introduced the necessary data, the model recognize the areas from which any point of the facades is successfully guarded. By reciprocity, the model is also able to give information of which part of the building is guarded from any point of the exterior. It can be made manually.

And, to conclude, the model can give the user the best set of points of view searching in multiple solutions by a Genetic Algorithm. This algorithm rewards solutions with a low number of points of view,

ODD Protocol:

1. Aim

1.1 What is the aim of the model?

The aim is to obtain the minimum number of viewpoints and the position, from which visualize the exterior walls of a building, in order to perform an architectural survey.

1.2 For what purpose has been developed?

The purpose is to minimize the working time and ensure a correct data collection process, in order to make a correct architectural survey, and no areas are left without visualize.

1.3 For what purpose is going to be used?

It is going to be used as a method with which any person who needs to make an architectural survey, having a good result with a minimal effort.

2. Entities, state variables and scales.

2.1 What kind of entities conform the model?

The turtles entities are:

- The vertices: they define the building plant
- The linesmen: they are agents that trace the area from which they are successfully observed
- The observers: any point of the exterior of the building is a possible observer. The more times an observer is inside an area of some linesman, the more the observer is guarding.

The link entities are:

- The facade of the building: they are connecting two vertices, shaping the walls of the building, and differentiating interior and exterior of the building.

Environments:

- Interior of the building: the interior of the building is an obstacle for the visualization. An observer cannot guard through this area. And also, a linesman is guarded from the exterior of the building.
- Exterior of the building: is the area in which the observers can be placed.
- Contour of the building : it coincide with the facade line.

Collectivities:

- Individual for the Genetic Algorithm: formed by observers turtles.
- Plant of the building: formed by vertices turtles and facade link agents.

2.2 What internal state variables or attributes characterize such entities?

Building vertices: they limit the facades. They are defined clicking in the position. It is interesting to know their coordinates. They have to be inserted orderly, clockwise.

Building facade: they shape the building plant, depending on the order in which the vertices had been introduced. They have to be wholly guarded by a set of observers. They separate the interior and the exterior sides of the building.

Interior of the building: it has a different color of the exterior side and the contour, white color. In this area no observers can be placed. This is a blind part.

Exterior of the building: it has no color. Observers can be placed in any part of the exterior of the building.

Contour of the building: it is the limit between the interior and the exterior of the building, and it is what is wanted to be guarded from the exterior. It coincides with the facade line.

Linesmen: every patch of the contour of the building is a place from which a linesman trace its cone vision. This cone vision is the area from which a patch of the building contour is successfully guarded, attending the technical features of the used instrument. It means that the area has a minimum radio, and a maximum radio, depending on the working range of the instrument. It has an aperture of 140°, as is described in the Snapchat 5. The trace is drawn to the exterior side of the building.

Observers: they can be placed in any point of the exterior of the building. They are patches from the exterior side. The model counts how many times a cone vision of a linesman has included this patch in its interior. So, the more cones vision had included a patch, the more points of the contour of the building is guarded from that observer.

Individual of the genetic algorithm: one individual is a possible solution to the problem of guard wholly a building from the exterior side. So, an individual is composed by a set of observers, who, together, are able to guard the building successfully.

2.3 What are the unities in which such variables or attributes are expressed?

Vertices: Cartesian coordinates.

Facades: they are between two vertices, which are defined by Cartesian coordinates.

Linesmen: they slip along the facades. So they start in a vertex and finish in another vertex linked by a facade line.

Observers: it is possible to know the Cartesian Coordinates of the patch of the Observers, and also, the number of patches of the contour of the building that the observer is guarding. Individual of the genetic algorithm: it is expressed with the Cartesian coordinates of the observers that compose it, and with the number of observers that compose it. Also, another value that can be associated to an individual is its Fitness Value. This is the result of having applied the Fitness Function to that individual, and this value gives back information about how suitable a solution is to the problem.

2.4 What is the spatial and temporal extension of the model?

The spatial extension is the plant of a building on a scale provided.

The temporal extension will be the runtime.

2.5 What level of spatial and temporal precision simulation will take with?

Space Accuracy: High

Temporal accuracy: Low

3. SUMMARY OF PROCESS AND PLANNING

3.1 What entity does what?

- Vertices: they define the shape of the building. They give information about the size and the disposition of the walls, or facades. They are introduced in clockwise order.

- Facades: they define the way in which the vertices are linked, and the separation between the interior and the exterior.

- Interior of the building: it is an obstacle of itself for the visualization of the building.

- Exterior of the building: it is the area from which is possible to guard the building.

- Contour of the building: it is the set of patches that must be guarded from the exterior side of the building.

- Linesmen: a linesman starts in a vertex and walks along a facade until the final vertex. In every patch that compose the Contour of the building, the linesman stops to trace the cone vision area from which that patch is successfully guarded, depending of the technical features of the chosen instrument.

- Observers: any patch of the exterior side is a possible observer. They guard more or less, depending on the times that a cone vision area had included a patch in its interior.

- Individual of the genetic algorithm: it is the set of observers that is able to guard the whole exterior side of a building. An individual is composed by several observers.

3.2 Which is the order in which the processes are executed?

o The vertices are placed to conform the plant of the building, clockwise, being consecutive those vertices that share a facade.

o The facades are drawn.

o The contour of the building is colored.

o The interior side is colored

o An linesman agent is launched from a vertex to the next one, clockwise. In every patch that compose the Contour of the building this agent traces its vision cone area, to the exterior side of the building, with a minimum and maximum radio, and a determined aperture angle.

o It is counted the times that a patch from the exterior side has been inside of the cone vision area of some linesman.

o The color of the patches of the exterior side are more intense the more times a patch had belonged to a cone vision area.

o The areas with a more intense are those from where more patches of the contour of the building are guarded.

- Genetic Algorithm:

o The initial population is generated with a determined number of individual. The number of observers that compose an individual is proportional to the number of facades, being equal to the half part of the number of facades. Initially, every individual has the same number of observers, but not everyone has to be in ON. The decision of being in ON or OFF is randomly made. An individual is coded with the Cartesian coordinates of the observers that compose it, and with the state of everyone, ON or OFF.

o The Fitness Function is designed to evaluate how suitable an individual is, depending on: the number of facades that are guarded and the number of observers activated. The Fitness Value is the value that an individual has, having applied the Fitness Function.

o A 80% of the population is selected to reproduce between themselves. The selection is made by a tournament selection. It means, two individuals are selected randomly, and that one with better Fitness Value is the individual that is selected. This process has to be repeated until complete the 80% selected.

o After the selection, the next step is the crossover between two selected individuals. From the selected individuals, two individuals are selected randomly. After having applied the Crossover Probability, that is a high one, if the Crossover proceeds, the cross point is

randomly selected, and two new individuals are created. The first one has the head of the father, and the tail of the mother. The second one has the head of the mother and the tail of the father.

- o After the crossover, the next step is the mutation, with a low probability. The new individual can mutate, changing the position of one of the observer, or more of one, in a random way.
- o The Genetic Algorithm will execute many iterations.

4. DESIGN CONCEPTS

4.1. Fundamental Principles

4.1.1 What concepts, theories, theoretical hypothesis lie behind the model design?

The designed model is based on the Genetic Algorithms techniques. Among the evolutionary techniques, the Genetic Algorithms are the most extended group of methods representing the application of evolutionary tools.

The theory of natural selection proposes that the plants and animals that exist today are the result of millions of years of adaptation to the demands of the environment. The organisms that are most capable of acquiring resources and successfully procreating are the ones whose descendants will tend to be numerous in the future. Organisms that are less capable, for whatever reason, will tend to have few or no descendants in the future.

For a search space with only a small number of possible solutions, all the solutions can be examined in a reasonable amount of time and the optimal one found. This exhaustive search, however, quickly becomes impractical as the search space grows in size.

In other sense, it's necessary to take into account the way in which the instruments work, and the range in which they respond with good results, and also the aperture angle of the instrument. It is important to think about that a facade is not correctly guarded unless the angle between the ray and the facade was bigger that a determined angle, which could be around 20° degrees, although it depends on the instrument.

Furthermore, it is important to consider that between different observers must have a good connection. The data acquire from a observers and the data acquire from another, cannot be joined unless between them existed a connection. The easier way is ensuring direct visualization between them, or considers an overlap between the visualization areas of observers that have to be connected.

The principal aim of the designed model is found a good set of observers that was able of guarding the building from the exterior side, being possible to connect the data of the different observers, and using for it a Genetic Algorithm

4.2. Aims:

4.2.1 What are the aims that the individuals pursue through the adaptation processes that govern their behavior?

- Vertices: define the way in which the facades are going to be linked.
- Facades: separate interior and exterior and give information for coloring the interior.
- Interior: it does not allow observers to be placed in it.
- Exterior: it allows observers to be placed in it, and it allows linesmen to trace their cone vision area over it.
- Contour of the building: It separates interior and exterior and gives information for coloring the interior side. The contour of the building is the line along which the linesmen are going to walk.
- Linesmen: they are going to walk along the contour of the building, launching a cone vision area from every patch of the contour, in order to evaluate the terrain, it means, evaluate every patch of the exterior side. Every patch of the exterior side will have the information of the times that a cone vision area had passed over a patch. In this way, all the patches are evaluated, and it is possible to know how many patches of the contour guards a patch of the exterior.
- Observers: any patch of the exterior side is a possible observer. So, after having launched the cone vision area, and having evaluated the terrain, it is possible to have the information of the part of the building that a Observer patch is able to guard.
- Genetic Algorithm individual: visualize all the patches that belong to the Contour of the building from the exterior side with the minimum possible number of observers.

4.3. Learning:

4.3.1 Do the adaptive features change over time as a result of the experience?

In the genetic algorithm, each generation is better adapted to the generation before.

4.3.2 How does these changes happen?

They happen because of the Fitness Function and the Selection Process.

The Fitness Function is applied to every individual of the population and measures how

suitable a solution is. The obtained value is called Fitness Value. The closer the fitness value is to an optimal value, the better that individual is. The Selection Process is the way in which new generations are created. Selecting the best individuals through the Fitness Function, the new individuals have the good genes of their parents.

4.3.3 Are they conscious changes, even planned, or are they just answers to the evolutionary environment?

Yes, they are. It is expected that, as happens in the real nature, the best individuals survive, and, the reproduction makes new individuals even better than their parents, because they inherit the good attributes from their parents. And so, generation after generation the population is better and better.

4.3.4 Do co-evolution processes happen due to the interaction between individuals and environment?

The environment does not change, only the population.

4.4. Interaction:

4.4.1 What kinds of interactions are relevant for the agents?

It is relevant the interaction between the agents Linesman and the patches of the exterior that are possible Observers. This relation is the most important, because the reciprocity of being guarded is the mean point in which the algorithm is based on.

4.4.2 Are they direct interactions, in which the meeting between them affects to themselves?

Yes, they are direct interactions because the relation is about direct visualization between them.

4.5. Randomness:

4.5.1 Which processes have been modeled assuming that they are, totally or partially, random?

In the Genetic Algorithm there are many processes that are based on the randomness. It is a fundamental principle of the Genetic Algorithm in general, because they treat to simulate the behavior of species.

So, the initial population is created placing the observers in patches chosen in a random way. Also, the observers that are ON or OFF are chosen in a random way. Another thing is the selection, which is a Tournament selection, in which two individuals are selected in a random way and the best one wins. Furthermore, the point in which the parents cut their chromosome, it means, the chain of values of the observers that compose them, is chosen randomly. And, to conclude, in the case of the mutation, an observer is changed randomly too.

4.6. Observation:

4.6.1 What data are generated and collected from the simulation for analysis?

The information that we collect is the position of the best points of view, being possible to know their Cartesian coordinates. Also, it is possible to observe the number of observers needed depending on the building complexity. Other information that can be collected is the evaluation of the terrain, being possible to consult any patch that could be interesting.

5. INITIALIZATION

5.1 How is the initial state of the model, this is, in the $t=0$ moment of the simulation execution?

At that moment, screen is black, waiting for the placement of the vertices that give shape the building plant. The vertices have to be introduced manually clicking in the places, and in a clockwise order.

5.2 How many entities shape the virtual society firstly, and which values do these variables have?

The first thing that it is going to be introduced is the placement of the building vertices, and after that, the facades are created linking two consecutive vertices.

5.3 Is it always the same, or can it change in different simulation execution?

Because it is a Genetic Algorithm, every time that it is executed it generates individuals in a different way.

5.4 Does the initialization correspond to a real state, that is, is it empirically calibrated, or are

random values?

The initialization corresponds to a real state, because it performs a real building. Also, the technical features of the instrument are real.

6. INPUT

6.1 Does the model use data from extern sources to perform processes that change during the simulation?

No, it does not.

Flow chart:

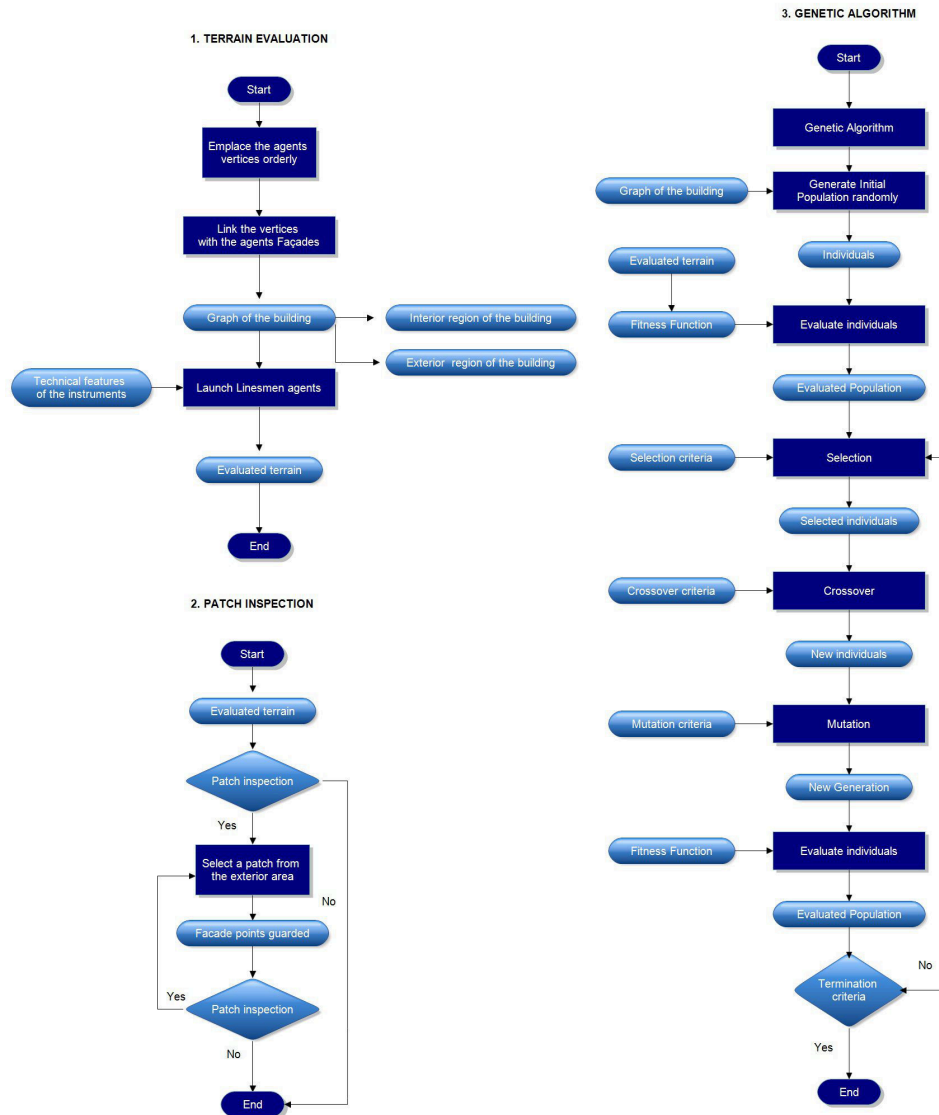

Code: N1_code.rar

View it on Github: <https://github.com/culturadigital/forma15/blob/master/N1.nlogo>

Model snapshots:

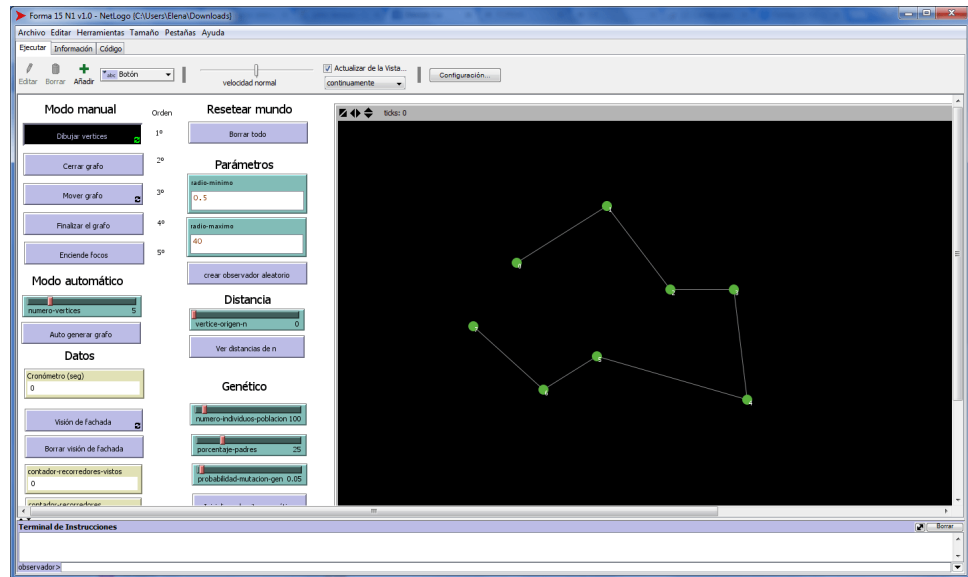

Fig. 1: Placement of vertices

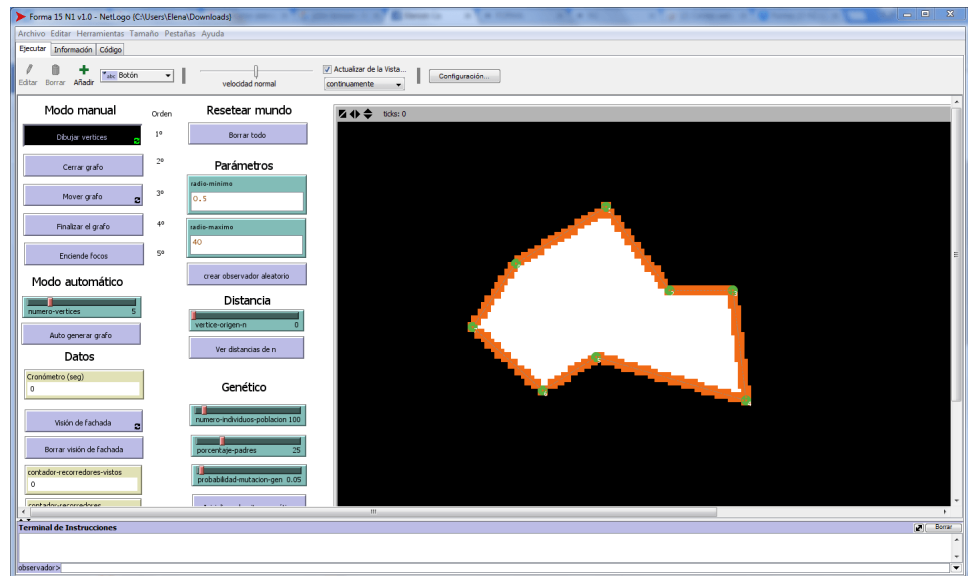

Fig. 2: Building plant

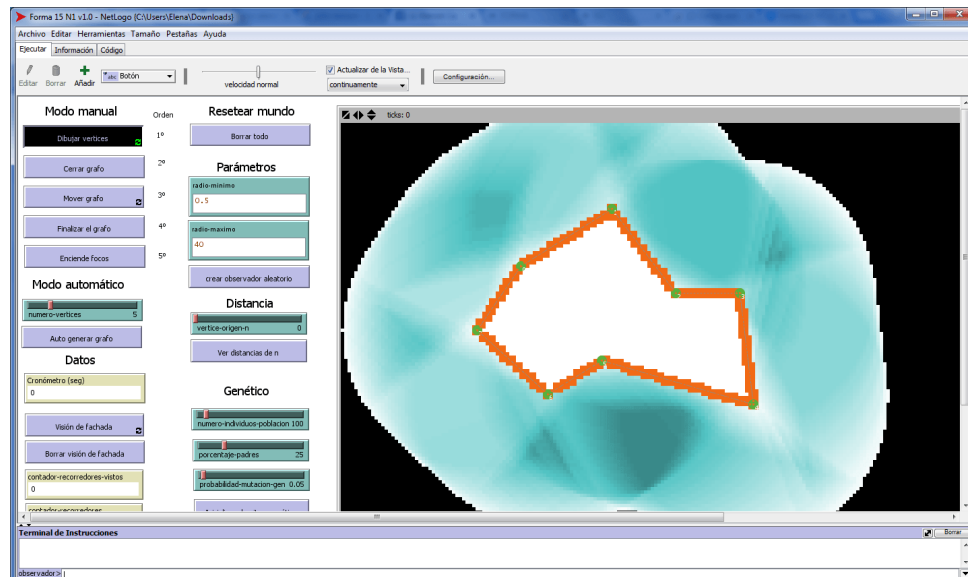

Fig. 3: Evaluated terrain

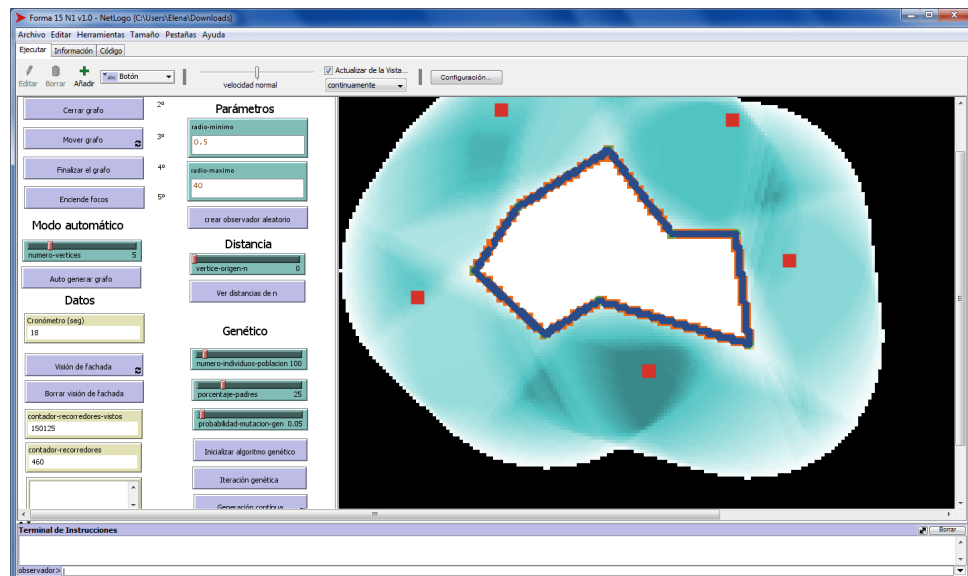

Fig. 4: Result of Genetic Algorithm

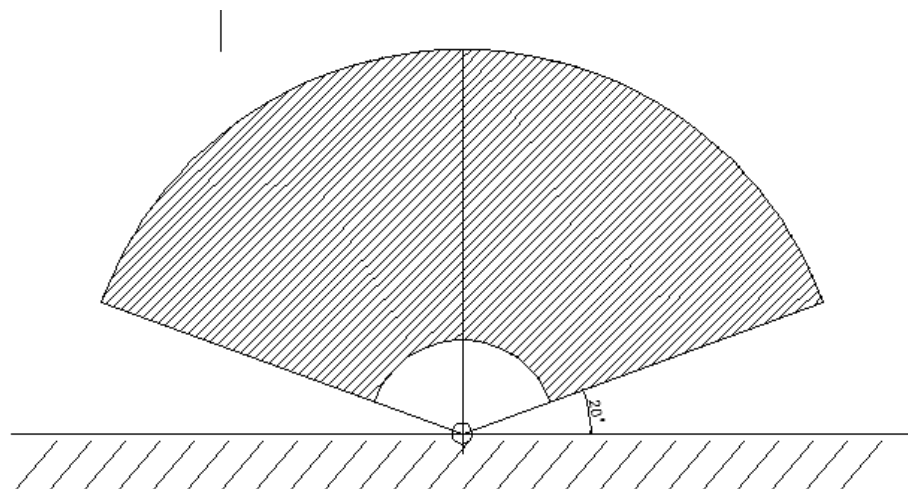

Fig. 5: Cone vision lanched from linesmen

Conclusions:

In this work it has been exposed the problem of guarding a building from its exterior side, posing a Genetic Algorithm to solve it. This algorithm tries to minimize the number of points of view that conform a set able to see the facades of the building wholly, with a particular given technical features, which depend on the chosen instrument.

The Genetic Algorithm has been implemented in NetLogo. The first thing that has been modeled it was the display features, as the way in which the vertices of the building are placed or the way in which the model is able of distinguish exterior and interior side of the building. After it, the Genetic Algorithm was implemented.

The designed model is able to locate the best set of points of view from which it is possible to obtain a good visualization of the exterior side of a building. As a first approach, it is a good result; and there are many possibilities to carry on developing the model, trying to consider more constraints, as the aperture vision angle.

It has been an interesting work, meshing different perceptions of the same problem, which has approximated a real work in the field of the Architecture to the students, and the most important thing, it has served to the proponents to see real results of the investigation.

References:

- O'Rourke, J., Art Gallery Theorems and Algorithms, Oxford University Press, 1987.
- Gestal, M., Rabuñal, J.R., Dorado, J., Pazos, A. Introducción a los Algoritmos Genéticos y la Programación Genética, Universidad Da Coruña, 2010.
- Almagro, A., Levantamiento arquitectónico. Universidad de Granada. 2004
- Alsadik, B., Gerke, M., and Vosselman, G., Optimal camera network design for 3d modeling of cultural heritage. ISPRS Annals of the Photogrammetry, Remote Sensing and Spatial Information Sciences, 3. 2012

CURVES OF PURSUIT

Which is the shape of the curves plotted by different agents that perform simple or cyclic pursuit?

Authors:

Juan Carlos Garcia Vazquez

Collaborators:

Juan Carlos Carrasco Zambrano
Jaime de Miguel Rodriguez
Jose Manuel Jarana Exposito
Angeles Linares Garcia
Antonio Manuel Nunez Dominguez
Miriam Romero Sanchez

Brief:

We consider a group of agents that perform simple or cyclic pursuit in different scenarios. We are interested in the type of curves plotted in the persecution, the existence of partial captures or total collapse of the agents in a single point, dependence of the curves with respect to initial conditions, different orders of persecution between agents, etc.

Methodology:

In our case, the mathematical-geometric character of the problem allows a direct approach to the problem. Agents are modeled in Netlogo by turtles that perform the persecution in the natural way in the plane or in the 3d space

Code: N2_code.zip

View it on Github: <https://github.com/culturadigital/forma15/blob/master/N2.nlogo>

Model snapshots:

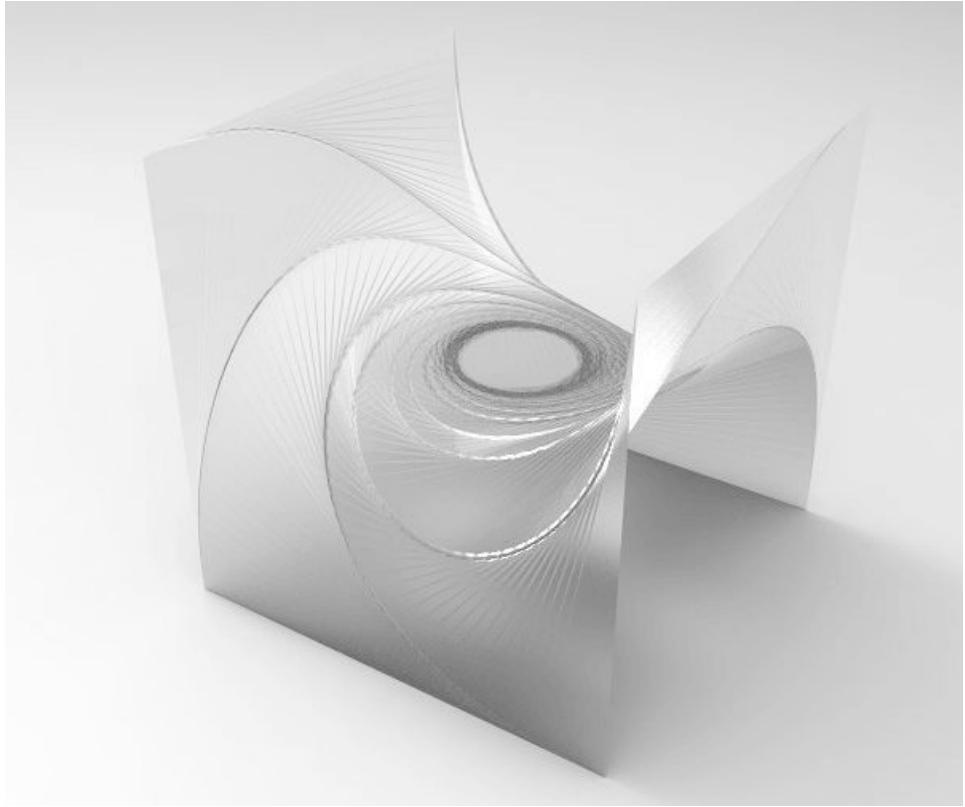

Fig. 1: Surface of pursuit between agents distributed along the vertices of a cube.

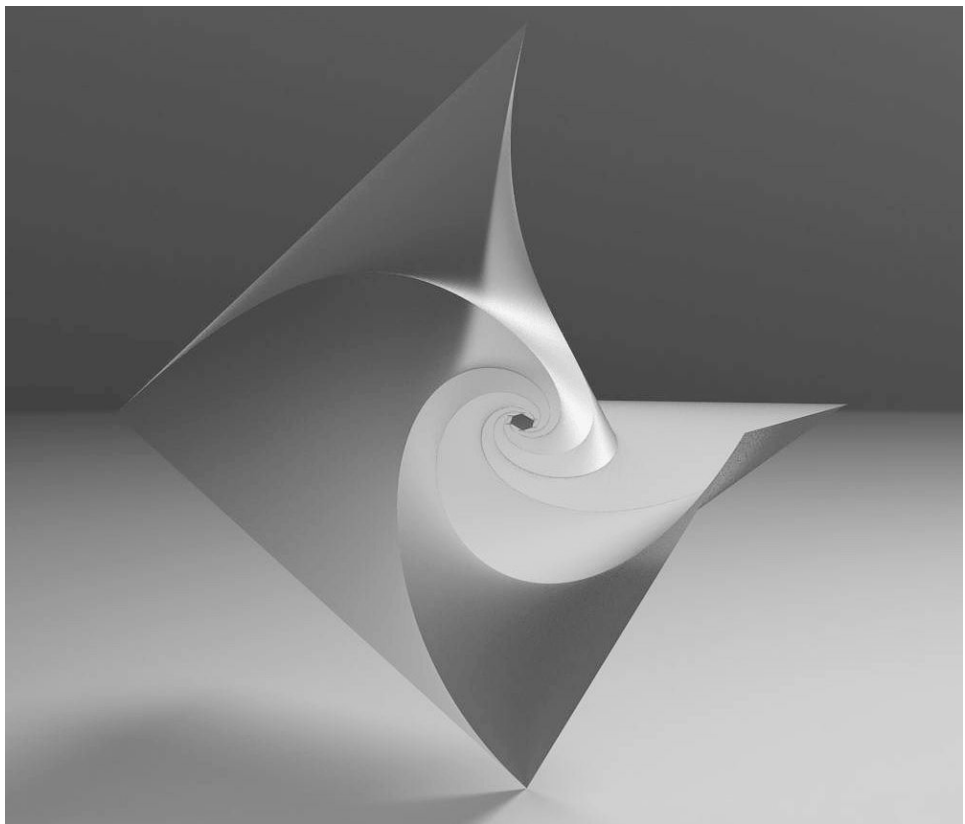

Fig. 2: Surface of pursuit between agents distributed along the vertices of an octahedron.

Conclusions:

We have modeled the following settings:

1) 2d models:

1.1. Simple pursuit: the problem of circular persecution.

1.2. Cyclic persecution:

1.2.1. Arbitrary number of uniformly distributed agents or initial positions introduced by the user

1.2.2. Different speed cases: randomly chosen, uniform, speeds introduced by user,

1.3. Different ground conditions.

2) 3d models:

2.1. Using Netlogo:

2.1.1. Agents in the vertices of a cube.

2.1.2. Different orders of persecution between the agents.

2.1.3. Visualization of the deformation produced on the cube.

2.2 Using Processing:

2.2.1. Agents in the vertices of a cube. Agents in the vertices of an octahedron.

2.2.2. Different orders of persecution between the agents.

2.2.3. Ability to export the generated surfaces to DXF.

2.2.4. Agents on surfaces NORBS with pursuit following geodesic surface.

References:

- A. M. Bruckstein, C.L. Mallows y I. A. Wagner, Probabilistic pursuit on the grid, American Mathematical Monthly, vol. 104, 1997, pp. 323--343.

FILL THE GAP[S]: DIGITAL SIMULATION TO FACE THE POST-BUBBLE CHALLENGE

Is it possible to define, through the use of simulation tools, a methodology of visualization of the degree of "renting" of the existing empty housing stock to link it with the satisfaction of the residential demands of citizens, according to the parameters that characterized the different actors involved in the housing process?

Authors:

Juan Francisco Fernandez Rodriguez
jfernandez52@us.es

Collaborators:

Irene Luque Martin
Carlos Jimenez Cobano
Alfonso Manuel Orta Rodriguez
Andres Fernandez Garcia

Brief:

There is no doubt that one of the biggest challenges for urban planning nowadays has to do with the reuse of the vacant housing stock that exists in lots of cities and towns around us. Spain is one of the European countries with the highest percentage of empty houses, and in parallel with major problems to ensure the access to housing to the population. So, the solutions for this problem necessarily involves the definition of strategies to put in use the empty houses as the first resource to satisfy the demands of citizens.

The problem arises when this challenge is considered as a global phenomenon. We talk about empty housing under statistical parameters instead of making an approach to the problem from the specific study of the existing housing stock in each municipality. Just the definition of the characteristics of the empty houses, the causes of which they remain empty, and their degree of "renting", as a parameter that express the facility to put them in use, will be able to evaluate the best strategies to act on them and offer an answer to the specific demands in each case.

The broad knowledge of the under-used stock characteristics - the location, age, estate of conservation, tenure, or causes that remain them unoccupied - as well as the information about applicants of houses, about their residential needs and access capabilities, will be the key to reach our purpose, being necessary for that to manage large amounts of information, from different nature and source, in a process that further simplifications must seek complex solutions.

At that point it will be necessary to incorporate to the study of the phenomenon of empty housing the use of modeling and simulation tools, able to link the characteristics of different actors involved in the housing process (applicants, owners, technicians, social entities, administration), as a methodology needed to understand the dynamics generated between them to settle down the basis for the development of subsequent phases of decision in the residential planning.

In this context the aim of this proposal will be to analyze how the incorporation of multi-agent simulation tools to the process of linking the vacant dwellings and residential demands will allow to visualize the degree of "renting" of the existing empty housing stock at the local field, to establish further strategies to solve the social challenge of access to housing by putting them in use.

ODD Protocol:

1. PURPOSE

The aim of the model will be to simulate the process of put in use of empty housing and satisfaction of residential demands with the participation of the different elements involved, to determine the variation of the percentage of vacant houses over the time, to relate the maximum and minimum peaks with the factors that cause them.

2. ENTITIES, VARIABLES AND SCALES

The model will consist of patches, global variables and agents, which are defined as:

PATCHES

We will define three kind of patches, depending on the use of ground according to urban classifications:

1. RESIDENTIAL
2. PUBLIC SPACE
3. COMMERCIAL

All the houses defined in the model will be linked to residential patches, being defined as: 1 residential patch = 1 house

We will assign a characteristic to the patches, which will be the "environment condition" linked to the degree of attraction of a house for applicants depending on the kind of patches around it:

Environment condition:

0. All patches around are residential
1. All patches around are public space
2. All patches around are commercial
3. Patches around are a mix of residential/public space/commercial

AGENTS

We will define two different agents in the model; Houses and Applicants (demand). The variables that characterize these agents are:

HOUSE:

Occupied: Yes / No

State of conservation: Good / Bad / Regular

Age: 0 (<5 years) / 1 (5-25 years) / 2 (25-50 years) / 3 (> 50 years)

Price: High / Medium / Low

Capacity: 1-6 people

The owner of the house will be an attribute of the house, with its own attributes, which will be linked to characteristics of the applicant desired by the owner.

Laboral status desired: Unemployed / Student / Employed

Age desired: Young / Adult / Elderly

APPLICANT:

Has a house?: Yes / No

Environment condition: 0/1/2/3

State of conservation searched: Good / Bad / Regular

Budget: High / Medium / Low

Age of applicant: Young / Adult / Elderly

Members of the family: (1-6)

Employment status: Unemployed / Student / Employed

GLOBAL VARIABLE:

Finally we will define a Global Variable, which will be assumed by the government, which will be characterized by its help to applicants to access to housing.

GOVERNMENT

Guarantor of access to housing (by specific policies): Yes / No

available funds: High / Medium / Low

Scale of assignation (for the rent of applicants): low / medium / high income

Scale aid groups (for the age of applicants): Young / Adult / Elderly

The model is developed temporarily in TICKS. Each one is equivalent to one year, which is the time that is considered appropriate to ensure minimum stability for an applicant to rent a house. That time also correspond to a reasonable period of time to consider changes in the

state of the building, which will influence in the price by the increase of the age. It will be a period, as well, that will consider the changes in the available funds of the government.

3. SUMMARY OF PROCESS AND PLANNING (SCHEDULE)

First of all we will define the action of every agent of the process:

- The action taken by the applicant will be to seek for a house to be rented according to its demands and characteristics.
- The action of houses will be to be occupied, by its characteristics or by the action of the owner that will look for the economic benefit of renting its house.
- The action of the government will be to provide help to the applicants to access to housing.

The point of start of the modeling process will be defined by the appearance of empty houses and applicants. From that point the first action taken by the applicants will be to occupy the houses that link with their demands directly (EASY RENTING)

- Houses that have a lower or equal price than their budgets.
- Houses that have a higher or equal state of conservation than searched.
- Houses that have a greater or equal capacity than the number of people in the household.

From that point the following steps will be linked to the action of the owners and the government, just when the conditions for the "easy renting" are not satisfied:

- Negotiation between owners and applicants to guarantee the occupation of houses (DIFFICULT RENTING). In this step we can define two situations:

1. The applicant is employed and the state of conservation of the house is higher or equal than the applicant's search. The owner will bring the price down 1 level.
2. The applicant is unemployed but could get funds from the government, and the state of conservation of the house is higher or equal than the applicant's search. The owner will bring the price down 1 level.

- Provide help to the applicants from the government (RENTING WITH HELP). When it is not possible the "easy" or "difficult renting", the conditions to get help from the government will be to have available funds and that the applicant's characteristics link with the conditions of assignment.

Over the time the state of conservation and age of houses will change, as well as their quality and value. The age of applicants and employment situation will change too. At the same time the government conditions will change, providing or not support to applicants, and so the model will change too.

4. DESIGN CONCEPTS:

The basic theory that this model and simulation is trying to support is that the convergence among all the agents involved in the housing process will, despite the limitations of either agents, ensure the occupation of empty houses and satisfaction of the needs of the demand under a system stable over the time.

As a strategy to develop the model we will establish the causes that are determining factors to guarantee the occupation of empty houses as variables of the different agents of the process, as well as the relationships established between them.

The system will initially be defined by five stages of work in the different scales of relationship between those agents involved in the process. These stages are:

1. Management of administrative data from social sources.
2. Incorporation of information about empty housing (visit, inspection) and housing applicants (survey, interview) as the first step to locate potentially "renting" houses.
3. Inclusion of data about potentially "renting" housing owners.

4. Definition of the degree of "renting" of existing empty houses, according to the data acquired in previous steps.

5. Definition of management strategies to put in use empty housing.

Thus the characteristics of applicants will be linked to vacant dwellings in a first step, with the owners appearing in the negotiation with the applicants when, for their conditions, it is necessary. The guarantee that applicants can offer to owners will have to do with their employment situation, economic status, or the capability to get support from the government, acting according to its budget capacity and political will.

The model will try to visualize the degree of "renting" of empty housing, defined as the factor that will link the degree of facility of renting a house and the degree of stable guarantee for the applicant. Under this idea we will define as degree of "renting" level 1 (DR1), those cases in which we have "easy renting" houses with applicants that remain in them over the time. The rate of this degree will have a lower level (DR2) linked to houses occupied in later steps of the process ("difficult renting" or "renting with help") and applicants that can not remain in those houses for a stable period of time. The lowest level of the degree of "renting" (DR3) will be linked to houses that can not be occupied in the process.

5. INITIALIZATION

In its initial state the model is composed of a distribution of patches of residential, public space and commercial use, randomly distributed. Each residential patch contains a house while in public spaces appear applicants waiting for the process of occupation of empty housing to start.

In the initial version of the model the physical environment will be abstract and following the description given previously. In a second version of the model, it was improved by incorporating a PNG file corresponding to a real sector of the municipality under study. Linking three assigned colors to the plots represented in it, the different type of patches; residential, public space or commercial, are located and distributed in a spatial way.

Flow chart:

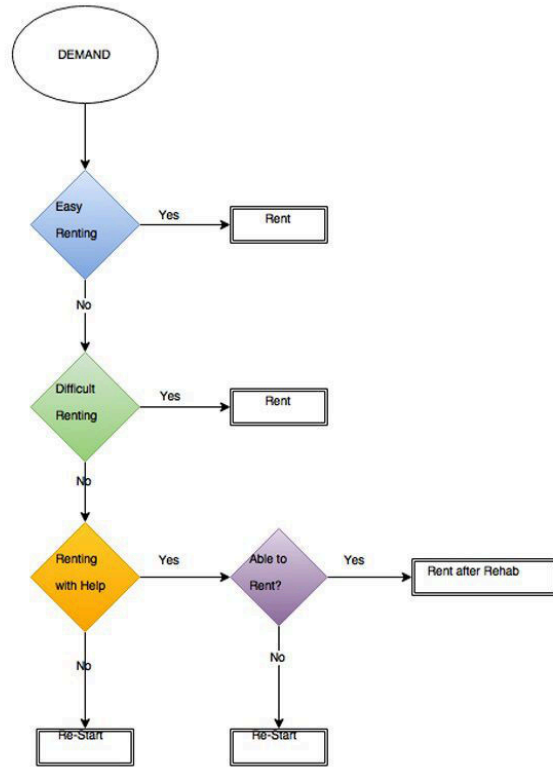
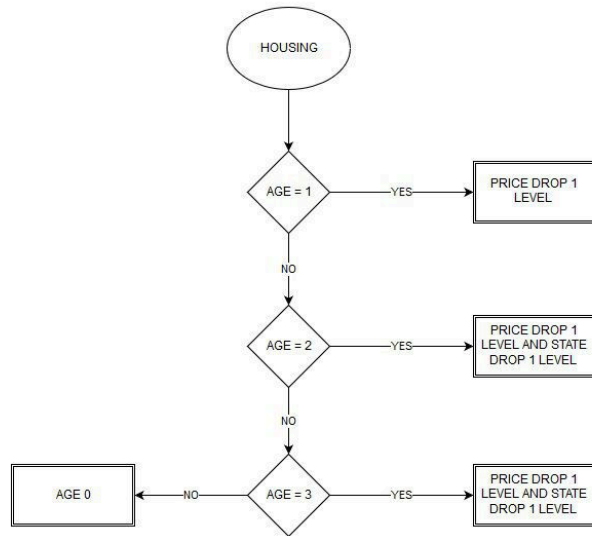
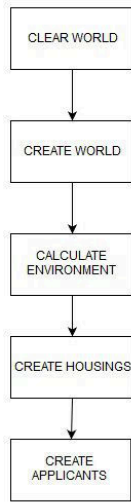

Code: N3_code.zip

View it on Github: <https://github.com/culturadigital/forma15/blob/master/N3.nlogo>

Model snapshots:

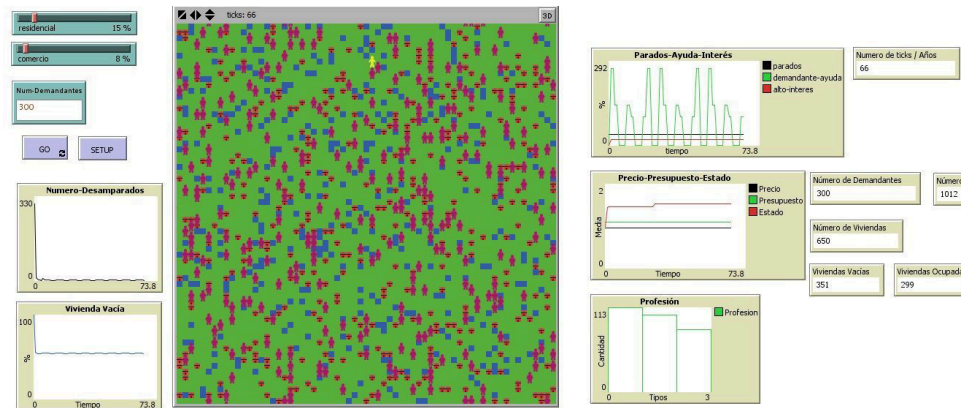

Fig. 1: Initial state. Initial version of the model

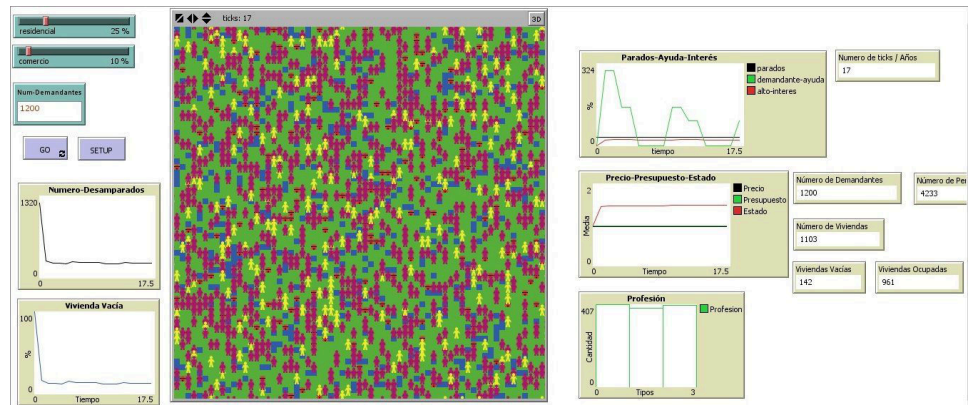

Fig. 2: State in process. Initial version of the model

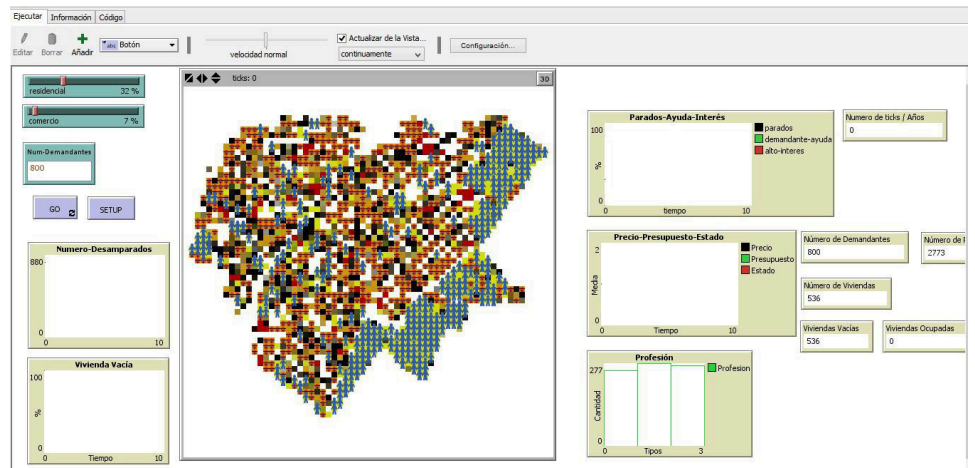

Fig. 3: Initial state. Version 2 of model with spatial distribution as real plane

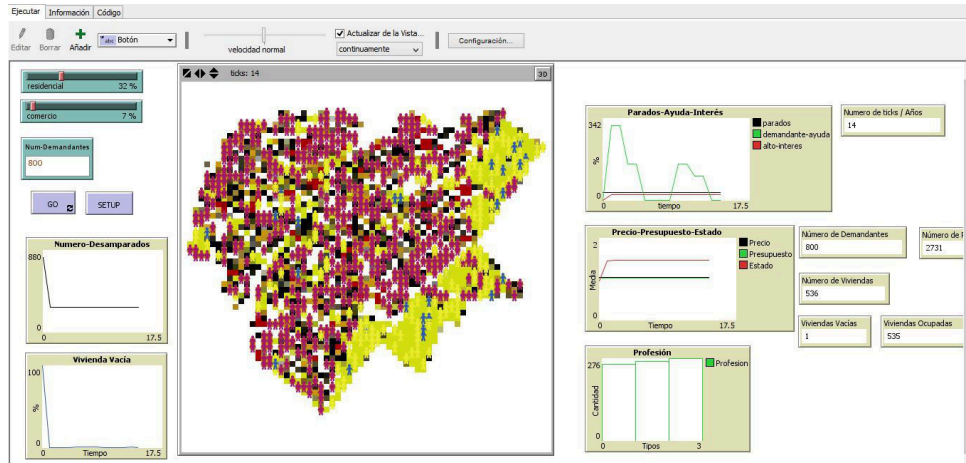

Fig. 4: State in process. Version 2 of model with spatial distribution as real plane

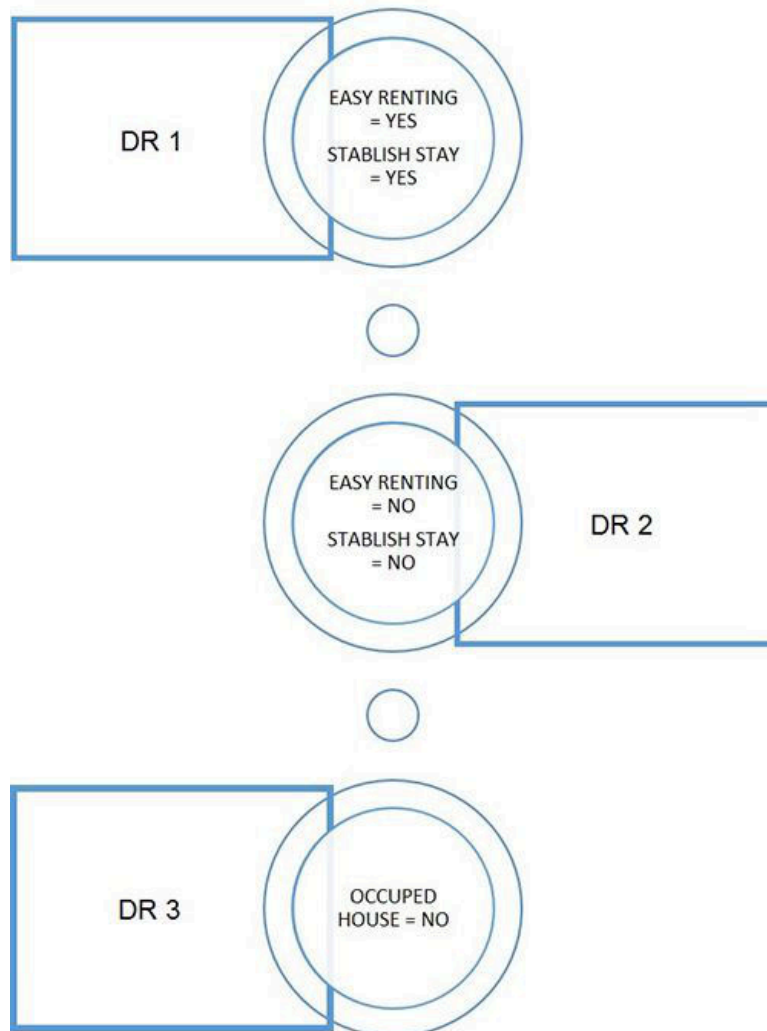

Fig. 5: Diagram degree of "renting"

Conclusions:

As conclusions of the work developed during the workshop, as a collective process, and from the specific results given by the model, we will evaluate the results attending to three points of view:

1. The benefits of the workshop process for the research and the topic proposed: First of all we will talk about these items that, being part of the original proposal, was necessary to "re-thinking" from a multidisciplinary group perspective, and how these new definitions bring to the research a richer point of view. The specific definition of who the agents are, their actions, variables and relationships, and the translation of these concepts to a different language supposed new ways of thinking that helped us to understand the system, as well as the aids of the model we were searching.

2. The specific information given by the model and the simulation developed: After thinking about all the elements involved in making the system works, the results given by the model bring to the research answers through the simulation and the graphics linked to it. In this case, we can determinate how the percentage of empty houses and applicants vary over the time, how the maximum peaks are related to the worst employment situation of applicants and periods of time without help of the government, and how the changes of the age of houses affects to the state of conservation and prices.

3. The keys to work in the future in a more complex model: After this first approach to the multi-agent simulation tools, it will be necessary to keep on working in a more complex system able to incorporate agents and variables ignored in this first step, to reach more specific results. In this way, and after incorporating this new complexity to the model, there are several ideas drawn as conclusions during the workshop that will be future lines of work:

a. Represent in the model previous periods of time to evaluate how the results obtained can link with the real situation lived, as a way of validating the model.

b. After defining the meaning of degree of "renting" in the model, and with the first approach to the spatial view of the results in a real map, we will define in a geographical way this degree of "renting" in a complex model, to determinate which parts of the city are in a best position to be occupied.

References:

- "From empty properties to new homes. Council's Empty Home Strategies". Stratford-On-Avon District Council. [https://www.stratford.gov.uk/...](https://www.stratford.gov.uk/)
- "Estudio del número de vivienda vacía en Andoain". Amaia Lujambio. Departamento de servicios sociales del ayuntamiento de Andoain. <https://jonpelaez.files.wordpress.com/...pdf>
- "Guía-modelo para la elaboración de planes municipales de vivienda y suelo". La junta de Andalucía lanza esta iniciativa vinculada al plan marco de vivienda, según el cual serán los municipios quienes, a través de esta figura de planeamiento, realizarán el análisis de su parque de vivienda y necesidades y demandas para, adoptar las medidas necesarias para atenderlas. [http://www.juntadeandalucia.es/fomentoyvivienda/...](http://www.juntadeandalucia.es/fomentoyvivienda/)
- 596 ACRES. Proyecto desarrollado en Nueva York, dirigido a visibilizar la enorme cantidad de espacio disponible y sin uso que podría ofrecerse como nuevos espacios libre y zonas verdes comunitarias en barrios donde escasean. Presentan una primera etapa de mapeo, catalogación y posterior apropiación, poniendo en relación estos espacios con las necesidades de las comunidades interesadas en su puesta en uso. <http://596acres.org/es>
- [IM]POSSIBLE LIVING. El objetivo de esta iniciativa desarrollada en Italia es visibilizar los edificios infrautilizados que puedan ser susceptible de un uso más intensivo, definiendo para ellos diferentes categorías según su uso previo, propiedad, características, para catalizar procesos de colaboración entre personas y colectivos que quieran dar soluciones creativas. <http://www.impossibleliving.com>

THE MONETARY SYSTEM AS A CAUSE OF ECONOMIC BANKRUPTCY. THE "SOVEREIGN MONEY" SOLUTION.

Is the current design of the monetary system an endogenous cause of bankruptcies in serie? Could the "Sovereign Money" proposal be a solution?

Authors:

Jesus Manuel Utrilla Trinidad
paleomodernidad@gmail.com

Collaborators:

Juan Galan Paez
Adrian Bretones Moreno
Sebastian Lozano
Antonio Paredes-Moreno
Rafael Arroyo Aleman

Brief:

The World has suffered an enormous recession, after a cycle of euphoria of credit in the financial markets.

International Movement for Monetary Reform (IMMR) was born to change the monetary system, because we think that the design of the monetary system of the eurozone and other developed countries causes a mal-function of all the economy.

The construction of the monetary system is the problem, because:

- 1-It is divided in three different circuits: cash, reserves and deposits.
- 2-Money used by the people is created by the banks making loans (=creating debt).

IMMR thinks that this system generates two main problems:

- 1-It puts the economy in the road of a general bankruptcy.
- 2-It doesn't permit to rescue the people and the real economy.

To prove it, we want to make a microsimulation of the system.

And we want to prove our solution too: the Sovereign Money. It consists in a new system with just one circuit and with the prohibition for the banks to create money. Just a democratic central bank can create money, and usually free of debt.

ODD Protocol:

1. PURPOSE

The model's purpose is to simulate the "fractional reserve" system (or money-debt system), and make it run, in order to observe the results of the credit booms over the economy.

2. ENTITIES, STATE VARIABLES AND SCALES

What kind of entities compose the model (agents / individuals, spatial units, environment, communities)?

The model defines some global variables:

- poor (too much debt)
- rich (very far to be poor)
- bankrupt (after n opportunities they can't pay their debts)
- middle class (people in a warm position) and bank-to-loan (a bank system that creates money through loans)
- income-max: maximum level of income in cash permitted to each trade
- xmax, ymax: in order to determine the randomly created movement of the turtles (persons trading) through the patches
- bank-loans: total loans created by the bank system; it could be limited

- bank-reserve coefficient: amount of money keep by the banks; from 1% to 100% of the savings
- bank-to-loan: new money created by the banks by making loans; the less the reserve coefficiente be, the more the money created by the banks will be

Turtles are persons interacting; number of people is selected by the observer (the central bank) from 400 to 1.500.

Turtles have some state variables for interacting among them:

- savings
- loans
- wallet
- temp-loan
- wealth
- customer
- bankruptcy?
- opportunities

Spatial extent is a square 17x17 cells.

There is no limit of time. But banks can loss their ability to create money if the whole population is in bankruptcy.

3. SUMMARY OF PROCESS AND PLANNING

The individuals (turtles) are moving through the patches. Some individuals (turtles) have money to trade with, and if there is another turtle who needs money in the same patch, they make a loan one to another, two, five dollars or nothing.

After this, people must then sort out the balance of their wallet with the bank. People will put a positive wallet balance in savings, or pay off a negative balance, a person will take out a loan from the bank if funds are available to borrow (if bank-to-loan>0). Otherwise the person maintains the negative balance until the next round. Lastly, if someone has money in savings and money borrowed from the bank, that person will pay off as much of the loan as possible using the savings.

If someone is in debts, and after n opportunities can't change his situation, he will be declared in bankruptcy; they will finish his economic life.

4.DESIGN CONCEPTS

What concepts, theories, theoretical assumptions underlying the design of the model?

We assume the ideas of IMMR about the construction of the monetary system. These ideas say that the bank system have an unlimited power of creation of deposits through loans.

When the bank industry begins a process of production of loans, it is impossible to stop a credit boom; the economy is full of money, but also is full of debt. Finally, bankruptcies in serie will appear, driving the whole economy to collapse.

Interest rates, in our model, are zero.

Do you use consolidated novel theories or model?

We have proposed an alternative monetary system based on the IMMR theories. We have called it "Dinero Soberano", and it can be run using the on/off button.

This theory propose to give money to the people directly, free of debt, avoiding the creation of debt circuits.

EMERGENCIAS: Which results in the model are expected to vary in complex ways and perhaps unpredictable inside a change of the particular characteristics of individuals or environment?

The "Dinero Soberano" alternative has an unpredictable development in the long run. May appear a situation of very high liquidity among the people that we have to treat.

ADAPTATION: Which adaptive traits have the individuals?

Do these features try to increase some kind of indicator of individual success related to its objectives?

In the money-debt system, the main adaptation is to call for debts in the moment that the rest of the people is doing it. In the "Sovereign Money" system, the passion is for liquidity free of debt. The first adaptation produces later on bankruptcies in serie, the second a high liquidity with a slow and continuous track of economic growing.

PERCEPTION: What state variables, internal or the environment, it is assumed that agents perceive?

Agents can perceive the behaviour of the rest of the people, because they can know how much debt and money they have. It produces an imitative behaviour, which generates the credit booms and later a great crunch in the economy.

In particular, they perceive savings, loans, state of the wallet and wealth of the other turtles (persons).

What is the scope of the signals that an agent can perceive, local or global?

Each turtle can perceive the signals of the turtle (person) who occupies the same patch than her.

INTERACTIONS: What types of interactions are assumed to be relevant between the agents?

The main interaction is among savers and debtors, and among the people with the bank system (a kind of great bank) on every patch. Operations of saving and borrowing are decided through those interactions.

Is there direct interactions, as if the encounters between agents influence over them? Yes: savings are formed directly in the encounters between turtles on each patch.

Is there indirect interactions, as if competing for an intermediate resource? Yes: the decision of lending is made by the bank system depending of the aggregate figures of the economy, which at the same time determine the capability of the turtles to get more money and pay one's debt.

RANDOMNESS. They are:

- The delivery of the total initial amount of money in cash.
- The movement of the turtles through the patches.
- The possibility of make a trade between two turtles is 1/2; if there is a trade, the possibility of interchange 2 or 5 dollars is 1/2 each one.

GROUPS. We have created four classes of economic agents in the economic order, who are changing while the system is running. The evolution of each class is one of the most important emergencies of the system.

These classes are defined by a single property: the relation among the savings and the loans of the turtle and the maximum income set by the programmer:

- if savings > income-max, the turtle is upper class (rich), it takes colour green;
- if loans > savings, the turtle is lower class (poor), colour red.
- if one turtle continues being poor after a number of opportunities (loops) established by the programmer, then that person becomes in bankruptcy, she finishes her interactions and she changes into yellow colour.
- Rest of the cases are middle class, in grey.

At the beginning of the running, 100% of the turtles are middle class.

OBSERVATION: What data are generated and collected from the simulation for analysis?

The simulation produces these data:

- Income distribution (%poor, rich, bankruptcies and middle class).
- Evolution of deposits and cash.
- Production of loans and money.

5. INITIALIZATION.

What is the initial state of the model, that is, at time $t = 0$ of the simulation run?

The initial phase is the tick = 0, with the distribution of patches and turtles.

Using the sliders, the observer can select:

- Expectations of the bank system.
- QE.
- Number of turtles.
- "Dinero Soberano" on/off.

How many entities are in the virtual society initially, and what values, accurate or random distribution, are the state variables of the entities? There are patches and turtles.

Patches are distributed within a framework of 17×17 .

Turtles are selected by the observer using a slider, among 400 and 1.500. They begin with random distribution on the patches and with $2 \times \ln(\text{com-max})$ (selected by the programmer) money in cash.

This just represent the real data in a reduced scale.

6. DATA ENTRY

Does the model use data from external resources (data files, or other models) to represent processes that vary in time during the simulation?

No, it doesn't.

7. SUBMODELS.

We can work with three models alternatively:

- A reserve system with a reserve coefficient among 0% and 100%.
- A reserve system as up, but with the implementation of a QE.
- A "Sovereign Money System".

QE permits a simulation of the predictable effects of an official Quantitative Easing over the system. We have simplified very much the effects: or no effects (x1) or can make double (x2) the effects of the reserve coefficient over the production of money and credit.

The "Sovereign Money System" is implemented by selecting "on" on the on/off button. Characteristics:

- Money is created mostly free of debt by the central bank, very slowly.
- Central bank creates money when dangerous bankruptcies in serie begin.
- Money is delivered giving an equal quota to each turtle.

8. SIMULATION AND EXPERIMENTAL

Which experiments can prove the validity of the model?

We have made all kind the experiments, and all have proved the validity of the model:

- Experiments changing the number of people.
- Experiments changing de QE.
- Experiments changing the expectations of the bank system.
- Experiments changing the reserves coefficient.
- Experiment implementing the Sovereign Money.

What representations can make from the variables of the study (measurable outcomes) to facilitate understanding of the model?

Two graphics: creation of money through loans and distribution of income.

9. MODEL ANALYSIS AND CONCLUSIONS

How the model behaves in front of the initial assumptions (known behavior under realistic conditions)? How does the model behave under unknown conditions?

The model behaves as we expect in all the experiments:

- 1- Under the money-debt system, it always finishes with bankruptcies in serie, under any conditions.
- 2- Under the sovereign money system, model behaves in the long run better than expected:

bankruptcies go under control (expected), creation of money is mostly free of debt and very quite (expected) and the upper class (people with much liquidity) at the end is the most part of the population (65%- not expected).

What possible improvements allowed the model to view the results? What interesting variations could be made?

Some improvements and variations could be made:

1- More realistic QE.

2- Put the people in different economic sectors.

3- Impose external stress conditions to prove the strength of the sovereign money.

4- Include interest payments.

5- Create some different banks.

6- Create a foreign trade.

7- Measure the inflation.

Etc.

Flow chart:

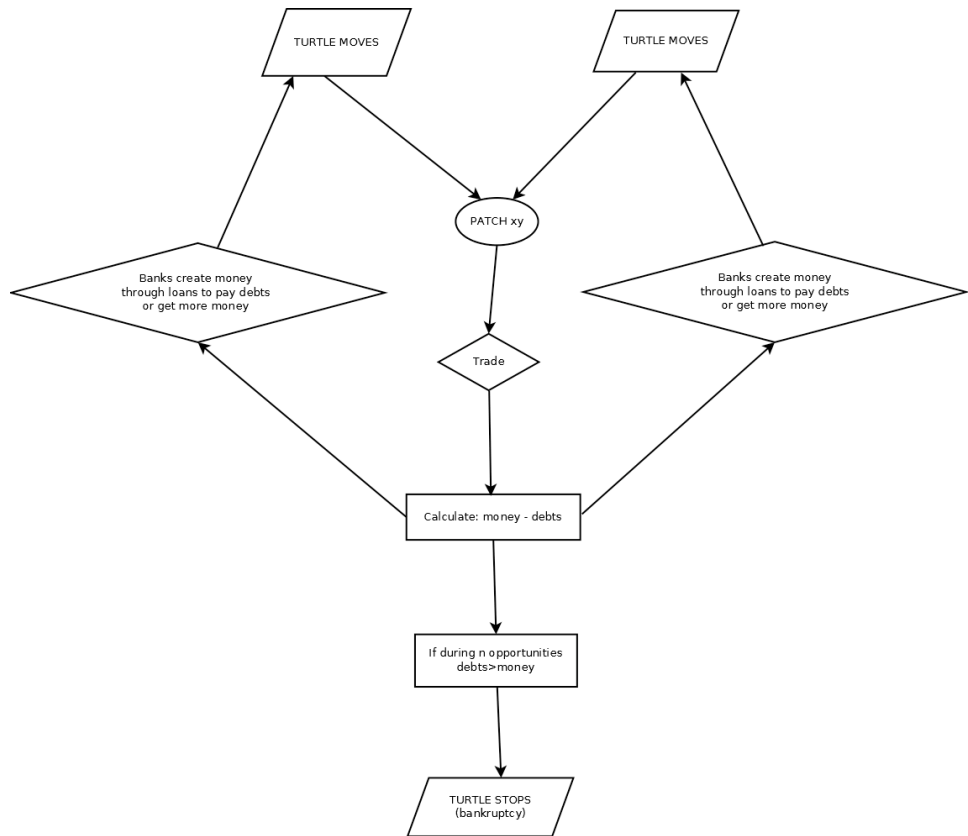

Code: N4_code.zip

View it on Github: <https://github.com/culturadigital/forma15/blob/master/N4.nlogo>

Model snapshots:

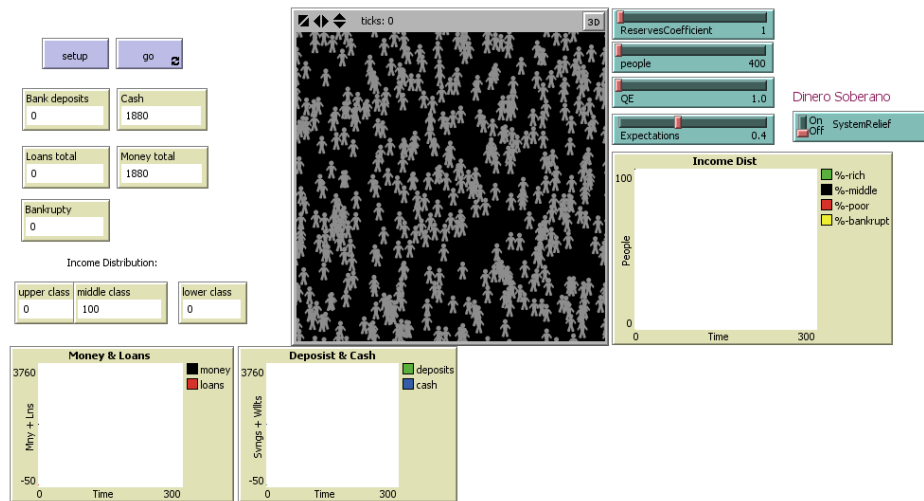

Fig. 1: CASE1: a) The system begins with a 1% reserves coefficient; 100% people free of debt; 1880 of total money in cash, randomly distributed; no QE.

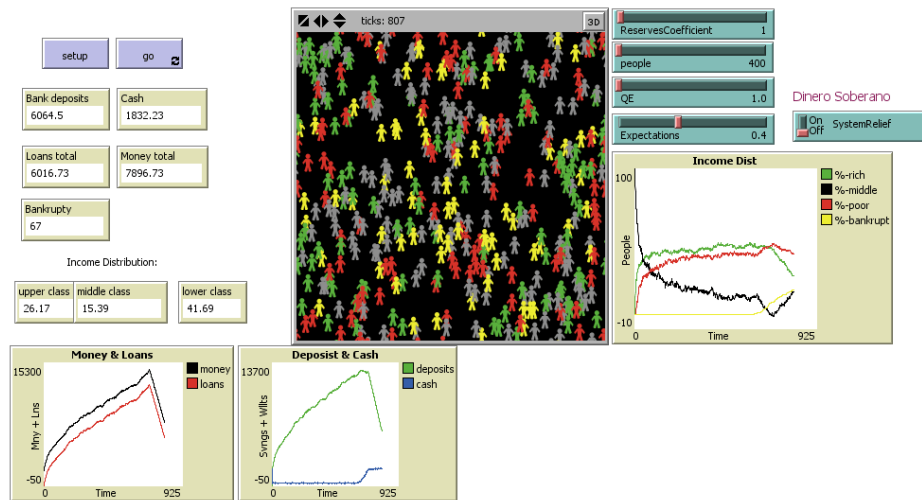

Fig. 2: b) After 807 ticks, the credit boom is exploding, bankruptcies in serie begin to appear

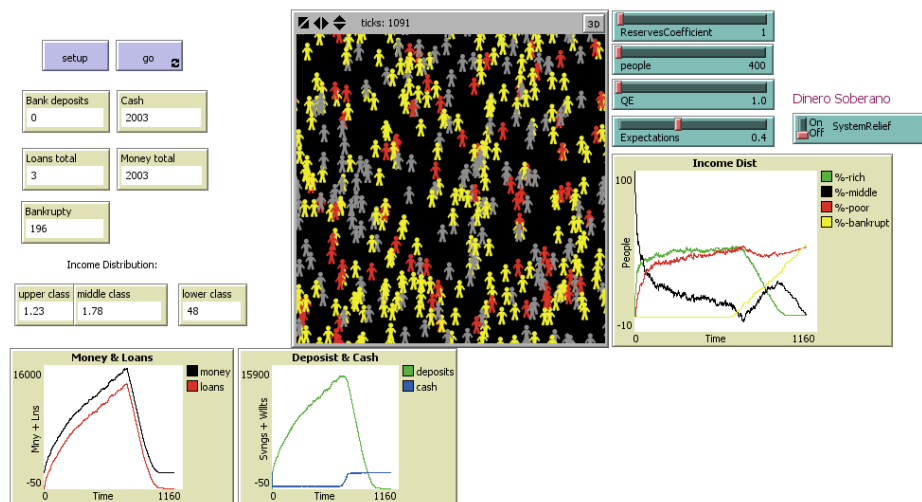

Fig. 3: c) Finally, we have destroyed the economy: most of the agents are collapsed by debts, few people has got almost all the economic power.

Conclusions:

CONCLUSIONS ABOUT THE MONEY-DEBT SYSTEM

We have improved a previous model included in netlogo by Wilensky, U. (1998). NetLogo Bank Reserves model. <http://ccl.northwestern.edu/netlogo/models/BankReserves>. Center for Connected Learning and Computer-Based Modeling, Northwestern University, Evanston, IL.

It is based in the "multiplier model of creation of money", which is uncomplete. It has given us a economy with three group of agents, plus the bank system that gives them the money through loans.

We have added three important facts:

- 1-The possibility of Quantitative Easing(QE).
- 2-The fact that agents with too much debt created in periods of credit booms, may fall down in bankruptcy after a time, closing many bussiness.
- 3- The Sovereign Money as an alternative system.

There are more facts to be considered in order to make the model more real. First of all the existance of different sectors in the economy, a calculus of inflation, GDP and other macroeconomic figures.

CONCLUSIONES ABOUT THE SOVEREIGN MONEY SYSTEM

With an on/off button, the observer (the central bank authority) may select the "sovereign money" system. It changes the way in which the system is running. The Central Bank can put money into the economic system giving them to the people (the real producers and the citizens) free-of debt.

Banks continue working, but they don't create money through debt too much, they just transfer savings. And the bankruptcies are under control thanks to the few debts and to the ability of the central bank to rescue his people.

THE RESULTS OF THE MICROSIMULATIONS

Both models (money-debt and sovereign money) run as the theory and historical evidence anticipate:

- Money-debt system creates a boom of credit that explodes in chain of bankruptcies under enormous debt, producing many people poor and few selected over-rich people.
- Sovereign Money controls the debt and the bankruptcies, with a slow creation of money mostly free of debt, leaving in the long term a few people with problems of debt (15-20%) and most of them in the upper class (60-65%). This last fantastic result was unexpected.

We need to improve the models by introducing more realistic conditions and variables, and testing the two systems under more complex situations.

References:

- "Monetary Reform, a Better Monetary System for Iceland". Frosti Sigurjonsson. <http://www.forsaetisraduneyti.is/...pdf>
- "Where Does Money Come From?". Josh Rya-Collins, Tony Greenham, Richard Werner y Andrew Jackson. Libro publicado en Reino Unido por la New Economic Foundation (2012).
- "Money in the Modern Economy: An Introduction". Michael McLeay, Amar Radia and Ryland Thomas of the Bank's Monetary Analysis Directorate. 2014. <http://www.bankofengland.co.uk/...pdf>
- "Money Creation in the Modern Economy". Michael McLeay, Amar Radia and Ryland Thomas of the Bank's Monetary Analysis Directorate. 2014. <http://www.bankofengland.co.uk/...pdf>

EVOLUTIVE PATTERNS IN ISLAND COLONIZATION PROCESSES

What is the colonization process that best explains the species distribution pattern in oceanic islands?

Authors:

Javier Fernandez-Lopez
jflopez@rjb.es
M^a Teresa Telleria
Margarita Duenas
Maripaz Martin

Collaborators:

Jesus Manuel Rodriguez Mazo
Diego Alonso Cancillo
Rafael Escudero Lirio
Ismael Huertas Fernandez

Brief:

Oceanic islands are laboratories to assess hypotheses about colonization, evolution and biological processes. Since they have never been connected with continental landmasses, they constitute an ideal scenario to study how and when colonization processes occur. Animals, plants and other organisms can arrive to oceanic islands through different ways, depending on their adaptations to some dispersal vector or even due to stochastic processes.

In our case study, we use a spatially explicit agent model to assess two different theories about the Canary Islands colonization. We study the case of the genus *Hyphoderma*, a wood-decay fungus that causes white rot. This fungus originated in Morocco coast and has colonized some Macaronesian islands, resulting in different speciation processes and developing several endemic species for each archipelago (Telleria et al. 2012).

Here, we use agent-based models as a work-frame in order to combine an underlying evolutive model with a spatially explicit ecological model. First, we model a dynamic population with several processes as asexual reproduction, dispersal and colonization depending on environmental suitability. Secondly, we implement a DNA evolution model in each dispersive agent in order to simulate genetic drift, taking into account genetic transition matrices obtained from real samples. Finally, we test two different theories about island colonization: random long-distant dispersion, depending only on distance; or anisotropic long-distant dispersion, depending on some dispersal vector like sea or wind currents.

We assess each theory by comparing simulation results with real genetic data, having into account different parameters as genetic diversity in each island or the colonization sequence through time.

ODD Protocol:

1) Purpose

The model was designed to explore different theories about oceanic island colonization. What are the variable that are modeling the biodiversity patterns observed in islands? What are the mechanisms that are mediating island colonization?

2) Entities, state variables and scales

The model has two kinds of entities: spores and square patches of land.

Patches make up a real landscape square of 2.5 km aprox. and are characterized by several variables: x-y coordinates, temperature, wind direction, name of the island/mainland and a hash table where are included the haplotype (DNA sequence) of each fungus and the occupancy percentage.

Spores represent the dispersive form of the fungus. They have three main variables: haplotype (inherited DNA sequence with probably some mutation), time-life (a kind of fuel for dispersion) and density (related with the probability of colonization).

3) Process overview and scheduling

The main process have several parts:

- Vegetative growing: Each patch with fungus occurrence can transfer some amount of

fungus to his neighbors

- Emission of Spores: Each patch with some amount of fungus create a spore per haplotype. The inherited DNA can be mutated following a transition matrix with some probability.
- Dispersion: Spores move following the hypothesis in test: randomly or having into account the wind direction in each patch. The spores move an specific distance per iteration. Spores consume a "time-life score" in each iteration
- Colonization: When the time-life of spores is empty, they check the suitability of the patch where they are. If the environmental conditions are suitable, the spore colonize the patch adding an amount of fungus related with spore "density" and the same haplotype as the spore haplotype.

4) Design Concepts

The basic principle addressed by this model is the simulation of island colonization following different hypothesis and the assessing of which one is in accordance with the real situation of the biodiversity patterns observed. The general idea in colonization processes in biology is that the closer is the place to colonize, the easier is the colonization. With this tool we test how other ways to colonization could be more agree with the real genetic patterns observed in oceanic islands, like anisotropic dispersion.

Stochasticity is used to represent a source of variability in the colonization process.

The output of the model tries to reproduce a real field sampling, allowing to compare simulation results with real ones.

5) Initialization

The landscape is initialized when the model starts. An optimal range of temperatures is arbitrarily selected (194 - 195) in order to create the initial distribution of fungus in Morocco coast.

6) Input data

Environmental variables (temperature, wind direction) are provided by .asc files. Other initial parameters, as transition matrix, initial DNA sequence or movement distance per iteration can be modified in the code.

7) Submodels

The DNA mutation submodel defines how DNA sequence should be modified when the spores are emitted. This submodel can be adjust in accordance with the genetic model of the species.

Flow chart:

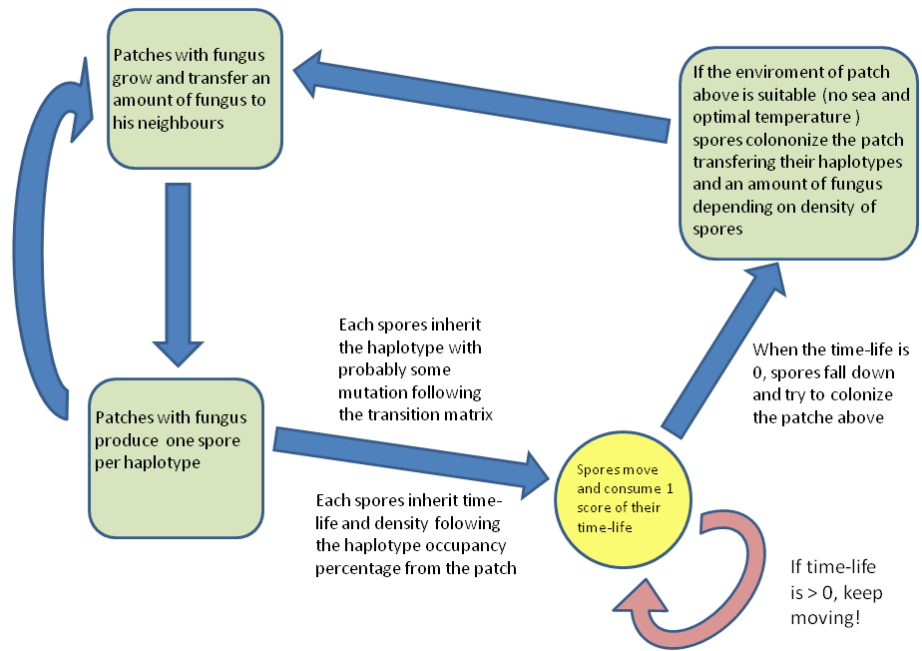

Code: N5_code.rar

View it on Github: <https://github.com/culturadigital/forma15/blob/master/N5.nlogo>

Model snapshots:

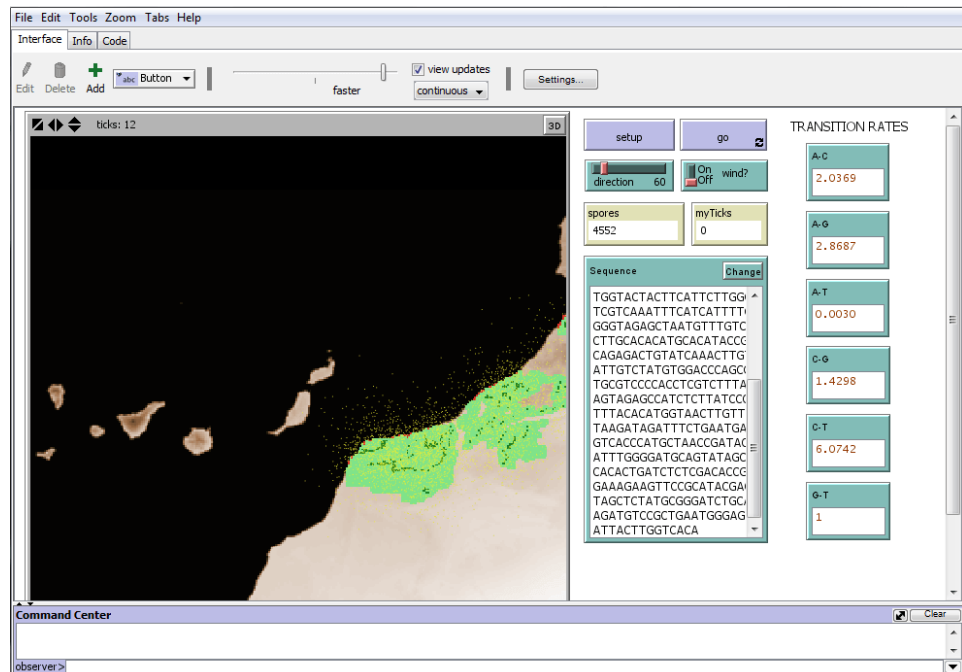

Fig. 1: Initial view of the simulation

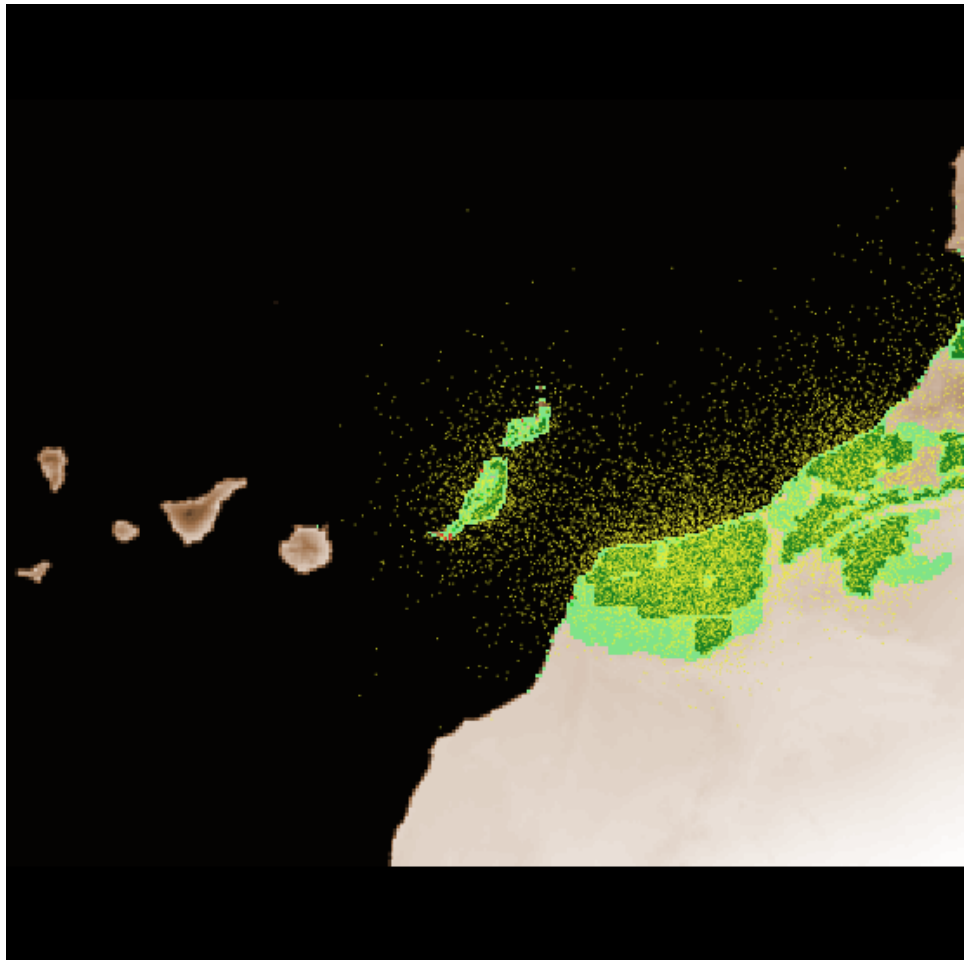

Fig. 2: Capture of a simulation assuming long-distance dispersion depending only on distance

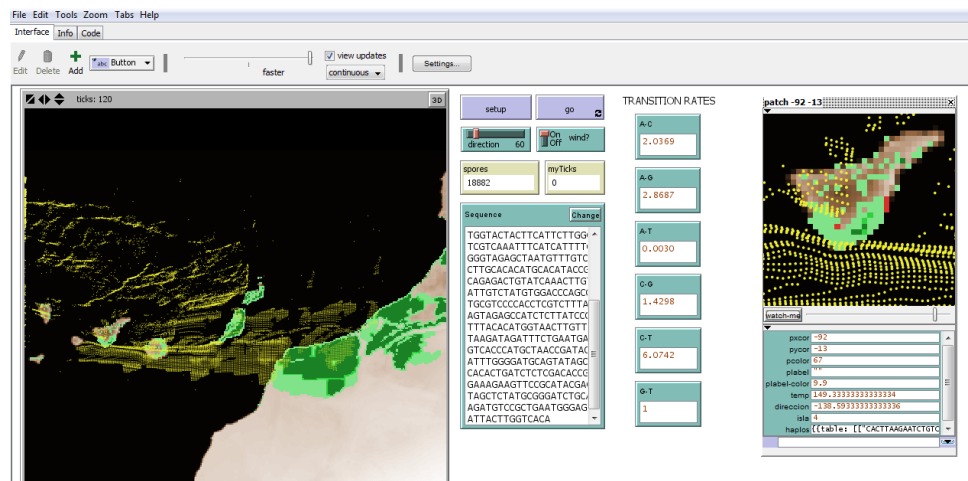

Fig. 3: Capture of the model assuming anisotropic dispersion (depending on wind direction)

Conclusions:

These simulations are useful in order to understand the underlying processes that can model the fungal biodiversity patterns observed in Canary Islands. The model can be modified and exported to other biological groups or other geographic region. Some experiments could be designed using BehaviorSpace in order to test different hypothesis. Moreover, changes in environmental conditions could be added in order to explore additional phenomenon like climate change.

In our specific case, we have demonstrated how considering environmental constraints to dispersion, as wind direction, the genetic biodiversity patterns can change significantly.

References:

- Telleria, M. T., Dueñas, M., Beltrán-Tejera, E., Rodríguez-Armas, J. L., & Martín, M. P. (2012). A new species of *Hyphoderma* (Meruliaceae, Polyporales) and its discrimination from closely related taxa. *Mycologia*, 104(5), 1121-1132.
- Grimm, V., Revilla, E., Berger, U., Jeltsch, F., Mooij, W. M., Railsback, S. F., ... & DeAngelis, D. L. (2005). Pattern-oriented modeling of agent-based complex systems: lessons from ecology. *science*, 310(5750), 987-991.
- Muñoz, J., Felicísimo, A. M., Cabezas, F., Burgaz, A. R., & Martínez, I. (2004). Wind as a long-distance dispersal vehicle in the Southern Hemisphere. *Science*, 304(5674), 1144-1147.

RECOVERING OF 24 MAY AVENUE IN THE HISTORICAL CENTER OF QUITO

What are the reasons preventing the recovery of 24 May Avenue in the historical center of Quito?

Authors:

Ivan Medina Carranco
ivan.medina@aecid.ec
Pedro Almagro Blanco
palmagroblanco@gmail.com
Elizabeth Regalado Bolanos
regaladoeli@gmail.com

Collaborators:

Cristian Naranjo
Ruben Tavora
Fredy Caisaguano
Francisco Javier Solis
Paulina Teran

Brief:

The public investments performed in the historical center of Quito since 1981, has been increased until now. At the beginning these investments were oriented to religious centers and in 1987 were focused on recovering the historical center from a hard earthquake. The architectural interventions were performed mostly in the nuclear part of the historical center (Plaza de la Independencia and religious buildings), promoting the tourism mostly to this nuclear zone.

One of the big problems that Quito is facing now is the recovering of historical zones that, although are not in the nuclear zone of the historical center are considered cultural heritage. Emblematic zones under this situation are San Roque, La Libertad, La Marin and 24 May Avenue. 24 May Avenue is the most representative zone of this group because is next to the nuclear historical center and there were architectural investments to prepare this zone for the tourism.

Despite efforts done by local and central governments tourists are not visiting the 24 May Avenue. The main problem that avoids tourism to visit this zone is prostitution, this zone is a traditional place for the prostitutes to work, this fact is connected with the proliferation of "negative commerces" that host prostitution services. In the area under study, many people has created hotels oriented to host tourism, but after a while they realized that there is not enough tourism in the area to maintain the service and they decide to become their hotels "negative commerces" in order to host prostitution services, this behaviour generates a vicious circle that avoids tourists to visit the 24 May Avenue.

ODD Protocol:

The main goal of this model is to analyze how different elements interact in the recovering process of 24 May Avenue and neighboring areas. In the model context, a zone is considered recovered if the number of tourists who visit it are over a predefined threshold. This model will be used in collaboration with Municipality of Quito to verify public policies in a computational context and to test their effectiveness.

The purpose of the model is to test how different public policies can help to recover the 24 May Avenue (decrease prostitution and increase tourism). We have modeled the prostitution, commerce and tourism subsystems. Prostitution and Tourism are subsystems that fight each other, commerce subsystem acts as an intermediate element that tends to favour the dominant subsystem (prostitution or tourism).

We use 5 different kinds of agents:

- Tourist

- Prostitution Client
- Prostitute
- Commerce ("Positive"/"Negative")
- Local neighbour
- Tourist attraction

Commerces can be "positive" or "negative", from a municipality point of view "positive" commerces means restaurants, hotels, hostels and cafes and "negative" commerces are places which host the prostitution services.

We use 6 different kinds of patches, one for each zone defined in the model: "Nuclear Historical Center", "La Ronda", "El Panecillo", "San Roque" and "24 May Avenue", we added a new kind of patch named "commerce area" that means that is a place where is allowed to start new commerces.

Tourists, prostitutes, prostitution clients and commerces has "energy" as main attribute:

- Tourists increase their energy if they are surrounded by local neighbors, "positive" commerces or tourist attractions. Tourists decrease their energy if they are surrounded by prostitutes or "negative" commerces. If a tourist visits a tourist attraction and come back to their original place with positive energy they will replicate (proportionally to his energy).

- Prostitutes increase their energy if they have enough clients. Energy of prostitutes decrease if they dont get any client in a temporal window. If prositutes energy go above a given treshold they will replicate (proportionally to their energy). If prositutes energy go behind a given treshold they will dissappear.

- Prostitution clients decrease this energy if they are surrounded by local neighbors or tourists. Prostitution clients increase their energy if they are surrounded by prostitutes or "negative" commerces. If a prostitution client visits a prostitute and come back to their original place with positive energy they will replicate (proportionally to their energy).

- Commerces increase their energy if they are surrounded by local neighbors or tourists. Commerces decrease their energy if they are surrounded by prostitutes. If a "positive" commerce energy go behind a given treshold it becomes a "negative" commerce. If a "negative" commerce energy go above a given treshold it becomes a "positive" commerce. A new "positive" commerce can appear if a "commerce area" patch is surrounded by local neighbors and tourists.

Here is a pseudocode describing the main process of the model:

1. Creation of initial agents guided by real distributions. Tourists born with a "tourist attraction" goal and prostitution clients born with a "prostitute" goal.
2. One-step-go: Each rule is applied to each agent.

Rules:

Tourists and Prostitution cleints: Look for their goal until they get them, then they come back to their origin. When they come back to the origin they replicate if they have enough energy.

Local neighbor: Random walk around 24 May Avenue.

Commerces: Evaluate his energy and transform to "positive" or "negative" if they have the right energy. Anytime can born a new "positive" commerce in "commerce area" if there is enough energy.

Prostitutes: Evaluate his energy and replicate or dissappear.

In the present model, a tick represents a minute and a patch represents a square meter. Spatial extent is a square 600x300 cells simulating the 24 May Avenue and the four neighbouring zones: Nuclear historical center, "San Roque", "El panecillo" and "La Ronda".

There are social, economic and territorial aspects that affect the behavior of the tourism in a historical zone. After analyze the real system through interviews with specialist and people who lives in this area we focused in which we think are the main subsystems: Tourism, commerce, local living and prostitution. For a more elaborate study we should take in account security and real state layers.

Although the initial position of each agent is random, the way the system generates initial agents respond to real espatial distributions, we generate tourist, tourist attractions, prostitutes and prostitution clients in each zone according to the real distribution of them in each modeled zone. To simulate public politics the model allows to increment/decrement number of initial tourist, tourist attractions, prostitution clients and local neighbors through multiplying by a factor the number of elements in each zone. Some parameters during the

execution of the model are random too: The way how the prostitutes decrease their energy waiting for clients and the initial energy of prostitution clients and tourists.

Flow chart:

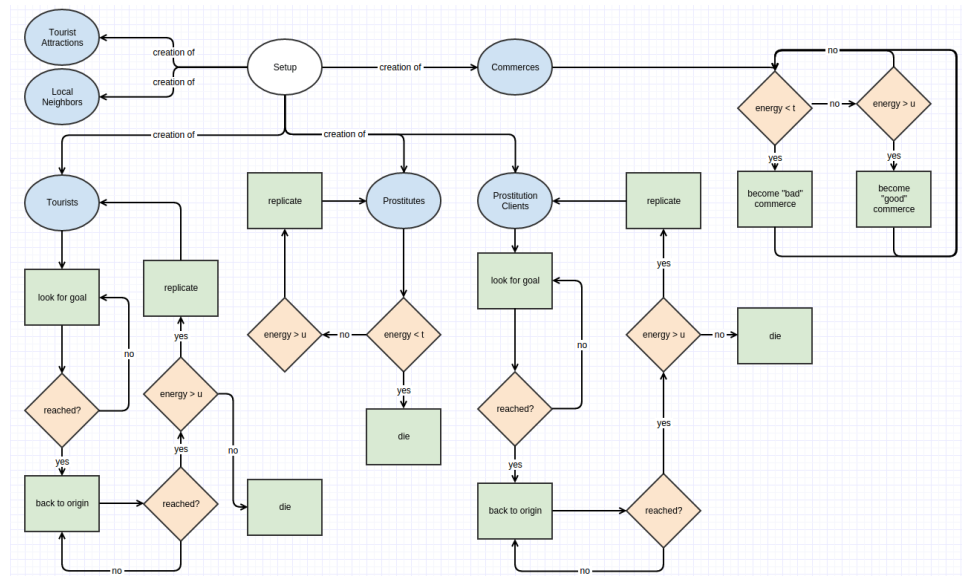

Fig. a: Flow Chart

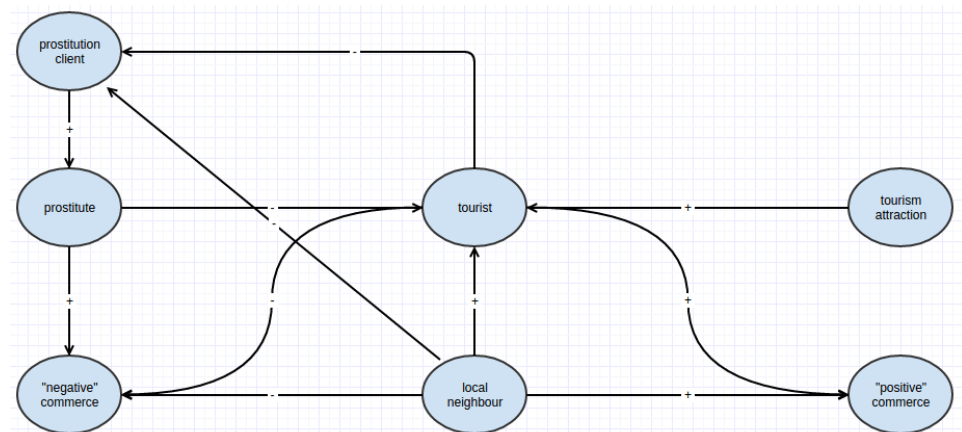

Fig. b: Positive and negative influences between different types of agents

Code: N6_code.rar

View it on Github: <https://github.com/culturadigital/forma15/blob/master/N6.nlogo>

Model snapshots:

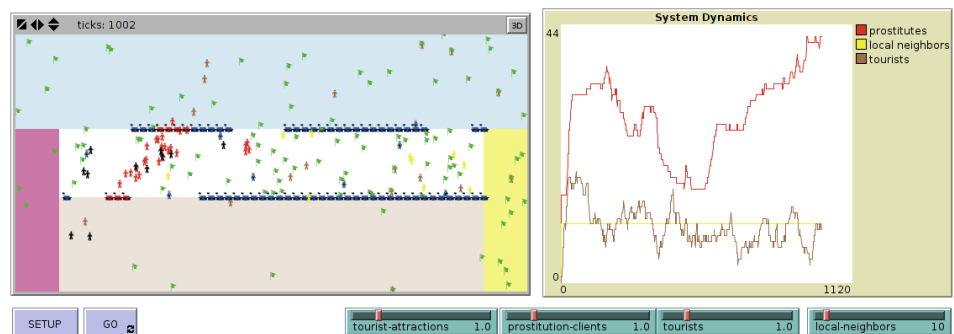

Fig. 1: Experiment 1: Actual state of the Avenue 24 May, prostitution persists and moves to

"San Roque" Area. Tourism remains low.

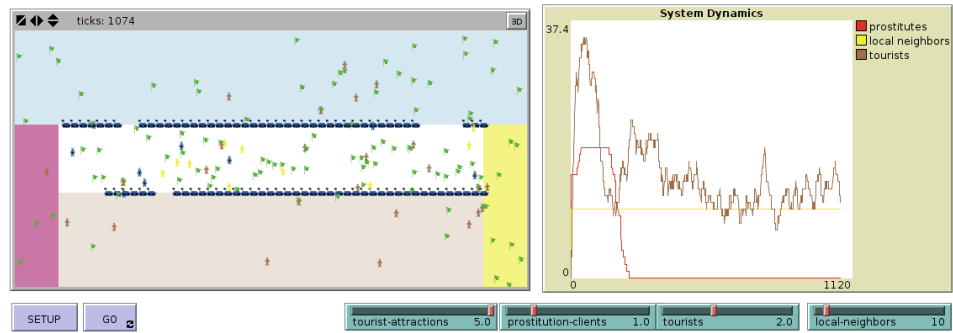

Fig. 2: Experiment 2: Simulating Public Politic 1 - Increasing Tourism Attractions (x5) and number of initial Tourist (x2). Prostitution disappear.

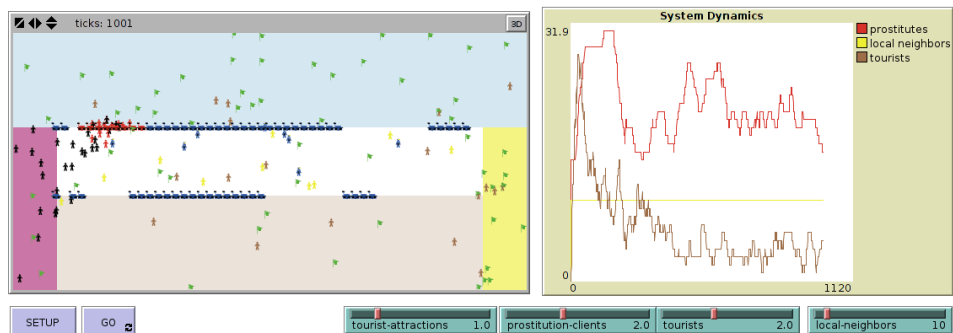

Fig. 3: Experiment 2: Simulating Public Politic 2 - Increasing tourists (x2) and prostitution clients (x2). Prostitution remains high and tourism remains low.

Conclusions:

After a simulation with the standard initial values (according to the actual situation of the zone) we can observe how prostitution remains as a problem and tends to polarize the distribution of the Avenue, moving the prostitution to the north part of the avenue and the tourism to the south part (exactly what is happening actually in the avenue). However if we modify the initial conditions we can change the evolution of the system, particularly if we increase (x5) the tourist attractions in the 24 May Avenue and increase the initial tourists (x2) the system tends to avoid prostitution and the tourism tend to fill the entire area. The model allow us to test different situations as for example a situation where all kind of visitors are increased (prostitution clients, local neighbors and tourists) but no new tourists attractions are added to the area, in this special situation the tourism seems to win his battle against prostitution but after a thousands of ticks it decreased giving way to a supremacy of prostitution.

â€

We have found two main problems during the development of this model: The fact that personal interactions (as prostitution services or tourist attraction visits) and commerce interactions (commerce becoming "negative" or "positive") have completely different time scale and the problem with the efficiency of the model because modelling at low level spatial behaviours of hundred of agents makes it slow to simulate. We plan to upgrade this model trying to fix this two problems: Modelling personal interactions as microsystems and creating a more abstract representation of the systems maybe using a graph based model instead of a patch based one.

A model like that will be very useful for the Municipality of Quito who is trying to recover the 24 May Avenue, this model will allow them to check which public politics are more recommended to implement under conditions we have taken in account. This model will be presented to Quito Municipality workers in order to test real public politics.

References:

- Municipio del D.M.Q. (2009). "Administraciones Zonales del Distrito Metropolitano de Quito".

- Evelia Peralta y Rolando Moya Tasquer.- Rescate de edificaciones históricas para la función habitacional. <http://www.vitruvius.com.br/revistas/read/arquitextos/03.028/751>
- Mónica Moreira.- Marco Legal de las Areas Históricas de Quito. <http://www2.archi.fr/SIRCHAL/seminair/sem3/contributions/quito.html>
- Mario A. Hidrobo M.-Experiencias Constructivas de la Rehabilitación Integral de la Casa del Alabado. ATP Seminario Arquitectura de Terra em Portugal. Junio 2007

EFFECTIVENESS OF SHARES CAPACITY DISCOVER THROUGH: COACHING-LEARNING METHOD CONSOLIDATION.

What's the most suitable in a capaciting process based on the actions Coaching-learning methodology?

Authors:

Ana Maria Orti Gonzalez
anaorti@siscapem.com

Collaborators:

Gonzalo A. Aranda Corral
Noelia Garcia Estevez
David Posada Mena
Jorge Canas Estevez
Juan D. Morillo Reina

Brief:

After years of research, we propose the concept "Emprendedorismo" as a body of knowledge aimed at enhancing the entrepreneurial spirit and social innovation of a community from a perspective that integrates multi-disciplinary approaches from complementary currents disciplinary social science. To do this, we need contributes to the consolidation of the concept as a scientific discipline method.

Coaching-learning is a methodology defined as: system actions for combined development of basic skills and transversal skills (both in the professional side and personal), which can be applied in the diagnosis and development of individual learning processes and group, to strengthen a system of skills management with the principles embodied in the philosophy of Management Excellence. All this we represent as Multiagent Systems Modeling. For representation initially use the tool of NetLogo.

ODD Protocol:

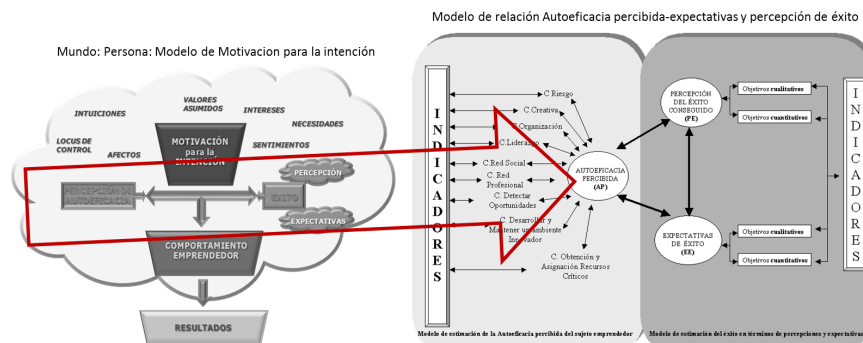

Orti, A. (2003): Fomento de la iniciativa emprendedora en el estudiante Universitario. La autoeficacia percibida emprendedora. Tesis doctoral. Sevilla. Julio, 2003.

ODD Protocol:

1. Overview

Purpose:

The molecular model we propose as a starting point for the development of multi-agent system is an adaptation of the Social Cognitive Theory of Albert Bandura in which we make a brief change: Change the RESULT concept, for the SUCCESS concept, because we understand that this Secondly displays a very strong when motivationally guide to action emotional component, and pick you up in the following sentence: "Expectations of success Motivation influence and predict behavior".

To explain the operation of the molecular model, we define a number of parameters (Agents) and we provide an initial value (which is the result of self-diagnosis questionnaires person with regard to AP, PE and EE).

Later we define a particular element (Target) and determine the energy level of the agents

according to the degree of orientation to the target.

Steps in the definition of the Entities:

In the modeling process we will follow these steps:

- Define the world: THE PERSON (proposed in point 1)
- Define Agents: AP (Perceived self-efficacy), EE (Expectations of success) and PE (Perception of Success) (proposed in paragraph 2)
- Identify the target (starting point for initiating movement)... (Blue)
- Define and measure Initial System States (person) based on perceived levels of it in their initial self-efficacy. These motivational states will be three levels:
 - o Passive (Orange)
 - o Neutral (Black Percent)
 - o Motivated (Green).

These initial states will depend on a combined function between the dimensions of the perceived self-efficacy:

- Level,
- Generalitat
- Strength.

The initial states and the degree of orientation marking target will be defining the energy states of agents.

5. Debug a specific scale measuring self-efficacy Enterprising, following a procedure based on Structural Equation Model, according to the requirements proposed by Bandura.

6. Modify the "Result" concept by the concept of "Success" and set the starting point on that basis. This starting point will call GOAL.

7. Define Success concept in qualitative and quantitative terms.

8. Propose a measuring scale according to the target set.

9. Identify the phases of the initial process

10. Calculate the sub-phases depending on the input information (these sub-phases will be those that include the individual's interaction with the immediate social environment (process coaching). This will lead to model educational simulation based on microprocessors information.

11. Establish concrete actions more effective coaching in the processes of interaction and how are you influencing the motivational process of the individual.

Flow chart:

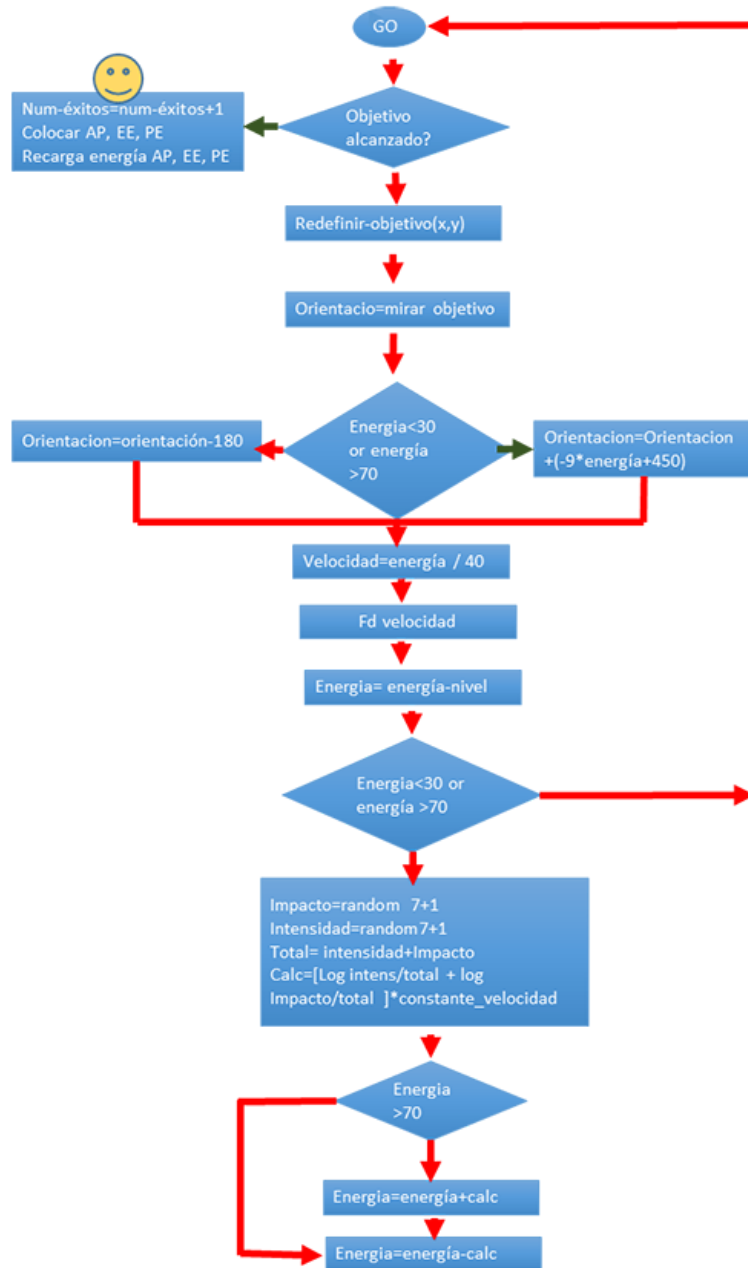

Code: N7_code.zip

View it on Github: <https://github.com/culturadigital/forma15/blob/master/N7.nlogo>

Model snapshots:

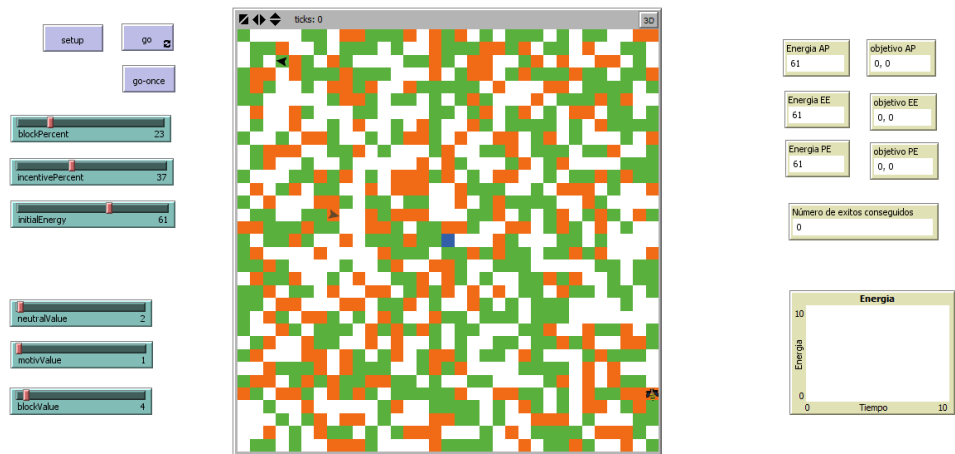

Fig. 1: System at startup

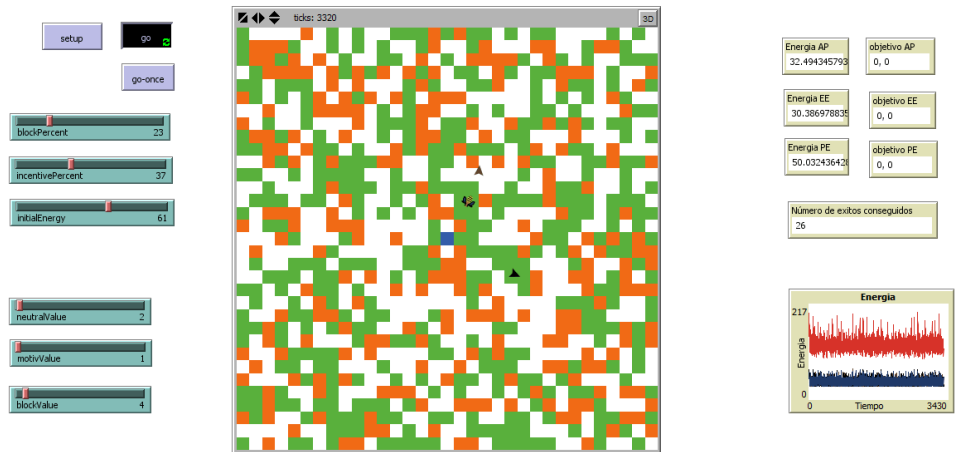

Fig. 2: System at runtime

References:

- Ana María Orti González. "Fomento del Espíritu Emprendedor: el Emprendedorismo". Editorial Académica Española, 2011
<http://es.slideshare.net/AnaMariaOrtiGonzalez/emprendedorismo-55125247>

MARITIME TRADE CADIZ. 1810-1812

How was the movement of ships and goods and which actors were involved?

Authors:

Luis Lopez-Molina
luis.lopez@uca.es

Collaborators:

Gabriel Munoz Rios
Jose Manuel Camacho Sosa
Ismael Dominguez Sanchez

Brief:

The location of Cadiz as a commercial strategic enclave, comes to explain the founding of the city by the Phoenicians, about the year 1100 B.C. However this work translates to almost 3,000 years later, convulsed 1810, 1811 and 1812, in which the Cadiz city acted as head of a state dismembered by the war with France and the beginning of the emancipation movements in the overseas colonies. Trade relations between the rest of the world and the european metropolis, helped the city of Cadiz to keep the hope of those who refused to give in to the domination of Napoleon.

If we focus on the period of the siege of Cadiz, those 30 months between 1810 and 1812, in which the Napoleonic forces had blocked the land access to the port city most important of Spain, it can understand the value of transfer of any goods. Remarkable, precious metals, whether in gold or silver, coined or even unminted for its high significance for the whole of Spanish society. During that period, no regent, merchant, rancher, owner, ie, any person, entity or country, that need to send flows to other places, have imagined how easy and safe it would be to send currency from one point to another including from overseas. However, until relatively recently, the risk borne by them was such that in some cases led to bankruptcy.

This merchandise was so valuable because it helped finance the war against the greatest army known so far. Private remittances, mainly based on trade, helped the Junta of Cadiz could make several loans to the Spanish Regency. And the public was destined, among other emergency, feed, supply and even to pay the troops who defended us.

This work could help simulate the movement of ships and goods (flags, consignees, etc ...) with a high degree of reliability, supported by a database that possess more than 3 million data created for my doctoral thesis (and defended) and I still expanding.

Methodology:

Data Mining.
Python and API Geocoding of Google, for the coordinates (latitude and longitude) of the location of the ports
Leaflet, to display coordinates on web maps.
R (programming language), to show best views on maps

Fig. 3: Image created during forma15

Conclusions:

Thanks to the tool used and especially the support and help of people who have made the Forma15, the visual impact of my work is not only better, but higher quality and precision. This causes the necessary explanations every researcher is forced to give, remain reduced by the visual effect caused greater control of the tools.

The results obtained support the initial thesis of the importance of commercial activity in the port of Cadiz during the Napoleonic blockade (1810-1812).

Thanks to this conference, a new range regarding future challenges opens. One of the biggest to be addressed, is to create the exact routes by sea and enter the type of vessel to which reference is made.

References:

- Alfonso Mola, M., 2009. Armadores y la Flota Mercante Colonial. La Guerra y las Transformaciones del Sector Naviero en el Antiguo Régimen. In C. Martínez Shaw & M. Alfonso Mola, eds. España en el comercio marítimo internacional (siglos XVII-XIX). Quince Estudios, p. 548.
- Cuenca-Esteban, J., 1981. Statistics of Spain's Colonial Trade, 1792-1820: Consular Duties, Cargo Inventories, and Balances of Trade. *Hispanic American Historical Review*.
- Fisher, J.R., 1993. El comercio entre España e Hispanoamérica (1797-1820). *Estudios de historia económica*, (27), pp.7-114.
- García-Baquero González, A., 1972. Comercio colonial y guerras revolucionarias: la decadencia económica de Cádiz a raíz de la emancipación americana Hispano-Am., Sevilla.
- López-Molina, L., 2014. El Puerto Gaditano en el Inicio del Ocaso de la Epoca Colonial (1810-1812). In N. Biangardi & M. E. Sandrini, eds. *Los espacios portuarios. Un encuentro entre disciplinas*. La Plata: Universidad Nacional de la Plata. Argentina, pp. 19-41.

