

Ozone generation in a wire-to-cylinder corona discharge ozonizer fed with mixtures of O₂ and N₂

K. Hadji¹, F. Pontiga², A. Belasri³, H. Hadj-Ziane¹, A. Fernández-Rueda²

¹ *Laboratoire de Génie Physique, Université Ibn Khaldoun, Zaaroura, BP 78, 14000 Tiaret, Algeria.*

² *Dpto. Física Aplicada II, Universidad de Sevilla, Av. Reina Mercedes 4, 41012 Sevilla, Spain.*

³ *Laboratoire de Physique des Plasmas, des Matériaux Conducteurs, et leurs Applications, Université des Sciences et de la Technologie d'Oran, El Menaouer, BP 1505, 31000 Oran, Algeria.*

The generation of ozone in a coaxial wire-cylinder corona discharge reactor has been experimentally investigated using variable proportions (5% to 90%) of oxygen in nitrogen. The experiments have been carried out under negative polarity and using different gas flow rates (50 cm³/min to 200 cm³/min). The obtained results show that the corona current exhibits a certain dependence with the percentage of oxygen in the gas mixture, which may influence the rate of ozone production. Moreover, the evaluation of the ozone yield has revealed a non-linear dependence of this magnitude with the concentration of oxygen. The maximum ozone yield was obtained when the percentage of oxygen in the gas mixture was about 70%.

1. Introduction

Ozone has numerous practical applications due to its extreme oxidizing power. Among the different applications of ozone, water treatment is particularly important since, contrary to chlorine, ozone does not leave residues because it decomposes spontaneously into molecular oxygen. Other fields of application of ozone include bleaching and chemical technologies. Large scale ozone production is usually based on dielectric barrier discharge. However, corona discharge can also be an effective means of ozone generation in lower scale applications.

The characterization of corona discharge ozonizers has been the object of investigation by numerous authors. These studies have focus their attention in different parameters, such as the corona polarity, the composition and temperature of the corona electrode, the humidity of the gas, the gas flow rate, etc. [1,2,3,4]. The influence of the gas composition has also received detailed attention [5,6]. Hence, it is known that the addition of small quantities of nitrogen may increase the efficiency of ozone production with respect to the case of pure oxygen.

In the present paper, we will present an investigation on ozone generation in dry mixtures of oxygen and nitrogen using a coaxial wire-cylinder corona reactor. Special attention will be paid to the influence of the ration O₂:N₂ on the corona current and on the ozone yield. The influence of the gas flow rate will also be taken into account.

2. Experimental

Figure 1 shows a schematic diagram of the experimental set-up used during the experiments.

The corona reactor consisted of a tungsten wire, 0.1 mm in diameter, placed along the axis of symmetry of a stainless steel cylinder of length 5 cm and inner diameter 17 mm. The two ends of the reactor were closed with UV grade quartz windows, and the entire reactor was situated inside the sample compartment of a UV spectrophotometer (Thermo Evolution 300). The reactor was fed with a mixture of O₂ (99.995% purity) and N₂ (99.999% purity) that was prepared with the help of two mass flow meters. The wire was energized using a high voltage amplifier (Trek 610C) and the corona current was registered with of a digital multimeter (Keithley 196).

The corona current and UV absorption were measured at regular intervals until steady readings were obtained. Then, using Beer-Lambert's law, ozone concentration was determined using a least

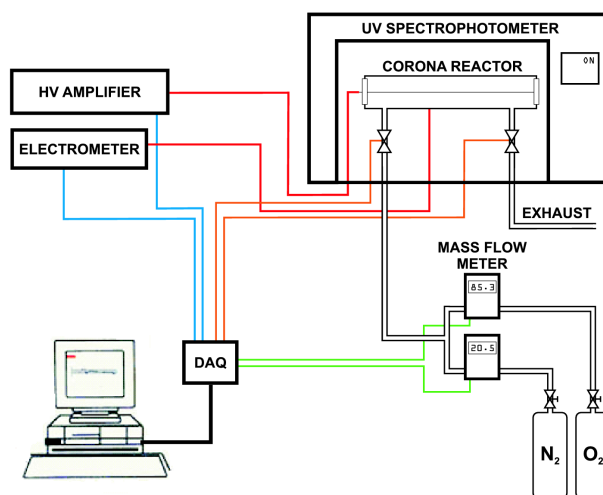

Figure 1. Schematic diagram of the experimental set-up.

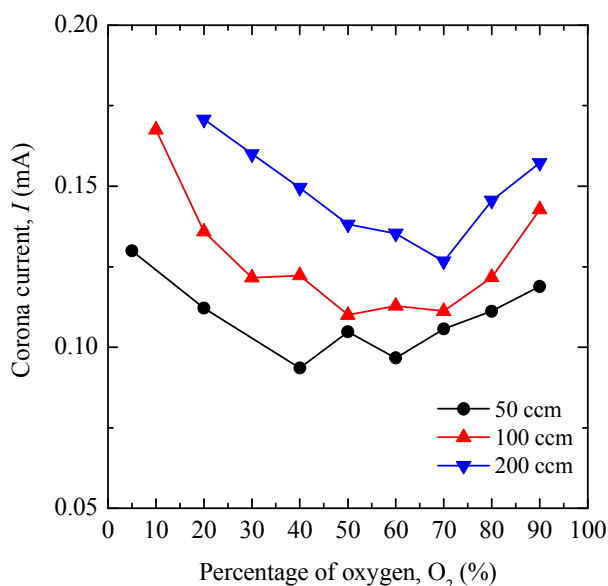

Figure 2: Corona current intensity as a function of the percentage of oxygen in the gas mixture for an applied voltage of -6 kV and different gas flow rates.

square fitting of the experimental absorbance on the wavelength range 220–280 nm.

2. Results and discussion

During the experiments, the applied voltage was fixed at $V = -6\text{ kV}$, and the percentage of oxygen in the gas mixture was varied in the range 5% – 90%. Three sets of experiments were executed, with flow rates $Q = 50, 100$ and $200\text{ cm}^3/\text{min}$.

The corona current, I , registered during the experiments is shown in fig. 2 as a function of %O₂ in the gas mixture. Clearly, there is a common tendency for all flow rates: the current intensity is slightly higher both at small and at large O₂:N₂ ratios. Moreover, at a fixed value of O₂:N₂, the current intensity increases with increasing the flow rate.

Ozone concentration at the exit of the ozonizer may be expected to be proportional to the operating power ($P = IV$), the transit time of the gas inside the ozonizer ($t \propto Q^{-1}$), and the concentration of oxygen molecules. The last factor, i.e. oxygen molecules, constitutes the source of atomic oxygen, which can later recombine with oxygen molecules in three-body collisions to form ozone. Therefore, assuming that a given fraction of power is consumed in the formation of ozone, the yield of ozone production, γ (grams of ozone per kW-h) $\propto [\text{O}_3]Q/P$, should be proportional to the percentage of ozone in the gas mixture. Such linear dependence is observed in fig. 3 for oxygen concentrations below 40%.

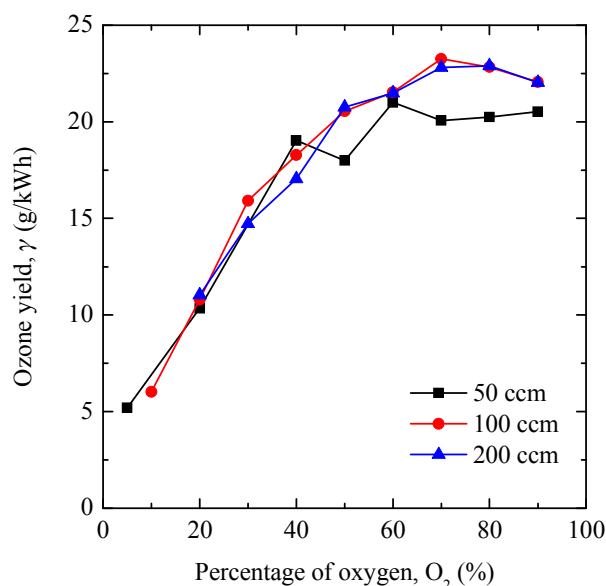

Figure 3: Ozone yield as a function of the percentage of oxygen in the gas mixture for an applied voltage of -6 kV and different gas flow rates

However, when the percentage of oxygen is further increased, the ozone yield tends to saturate and slightly decreases as 100% of O₂ is approached. This behaviour may be attributed to the role played by nitrogen atoms and electronically excited nitrogen molecules in the dissociation of oxygen molecules, since these processes become less important as the percentage of oxygen is augmented.

3. Acknowledgement.

This work was supported by the the “Consejería de Innovación, Ciencia y Empresa (Junta de Andalucía)” and the “Ministerio de Ciencia e Innovación”, Spain, within the European Regional Development Fund contracts FQM-4983 and FIS2011-25161.

3. References

- [1] M. B. Awad and G. S. P. Castle, *J. Air Pollut. Contr. Assoc.* **25** (1975) 369-374.
- [2] T. Ohkubo, S. Hamasaki, Y. Nomoto, J.-S. Chang And T. Adachi, *IEEE. Trans. Ind. Appl.* **26** (1990) 542-549.
- [3] K. J. Boelter and J. H. Davidson, *Aerosol Sci. Tech.* **27** (1997) 689-708.
- [4] J. Chen and J. H. Davidson, *Plasma Chem. Plasma Process.* **23** (2003) 501-518.
- [5] J. D. Skalný, T. Mikoviny, N. J. Mason and V. Sobek, *Ozone Sci Eng* **24** (2002) 29-37.
- [6] R. Peyrous, C. Monge, B. Held, *Czech. J. Phys.* **49** (1999) 289-299.