

Multilayer optical strip for illumination, imaging and analysis

E. Gomez-Gonzalez^{*}, J. Marquez-Rivas^{**},
M.A. Perales-Esteve^{***} and M.J. Mayorga-Buiza^{**}

^{*}Department of Applied Physics III, Engineering School, University of Seville, Spain, egomez@us.es

^{**}Service of Neurosurgery, University Hospital “Virgen del Rocio”, Seville, Spain

^{***}Department of Electronic Engineering, Engineering School, University of Seville, Spain

ABSTRACT

This paper presents an optical device (multilayer optical strip, MOS) composed of a strip-shaped, multilayer, planar structure connected to a remote control unit. Active and passive optical elements in overlapping layers of the optical strip define different configurations for specific applications, including illumination, optical analysis, imaging and optical communication and control of other devices. The strip can be flexible, rigid or of variable shape. It can be attached to existing instruments and tools to access cavities, conduits and hard-to-reach locations with irregular or changing boundaries. It can be of small size, powered on batteries, portable and cost-effective. Main areas of application of this device span from surgery, medicine, dentistry, biology and veterinary to optical sensing of pollutants and pathogens, industrial inspection and quality control. It is also suitable for use in small spaces such as vehicles, in emergency or disaster areas and in low-resources or developing environments.

Keywords: planar optics, multilayer optics, illumination, imaging, optical analysis

1 DESCRIPTION

The presented multilayer optical strip (MOS) is composed of two main components: a so-called “optical strip” and an additional unit for power supply, thermal regulation, signal conditioning, control and, if required, data transmission and recording. The optical strip combines overlapping layers of active and passive optical elements (OEs). Several optical strips can be connected to a common control unit to define specific emitter-receiver geometries. Proper cables connect the control unit and the strip/s. Active layers of the strip may include light emitting and receiving elements, liquid crystals and linear and array image sensors, while passive layers may include color filters, diffracting grating and components, and micro and planar lenses. An additional metallic layer provides structural strength and heat removal.

OEs in active and passive layers allow for controlling the properties (intensity, color temperature and spectral composition, polarization), spatial structure and time intervals (pulses, sequences) of the light emitted or received

by the active elements. A key element in the design for intended applications is the strip (band) shape of small size. Typical dimensions of current prototypes combine widths of 5-10 mm and thicknesses of 2-5 mm with variable lengths, from 50 mm to those required by specific applications. Fast-evolving technological improvements in small, planar optical elements can be further incorporated and will allow for scaling down dimensions [1]. The control unit provides electrical power to the strip and drains heat from active OEs. This external unit also synchronizes signals and receives data, measurements and images, and allows for additional computer connections and connectivity. Depending on the structure and materials of the layers, the shape of the strip/s can be adapted so that they can be attached to instruments and tools using either mechanical fixation, magnets or adhesive layers. The strip/s can be sheathed for specific environments and sterilization or be disposable. Depending on the number and type of layers and OEs, the whole system can be portable, very cost-effective and easy to manufacture [1-2].

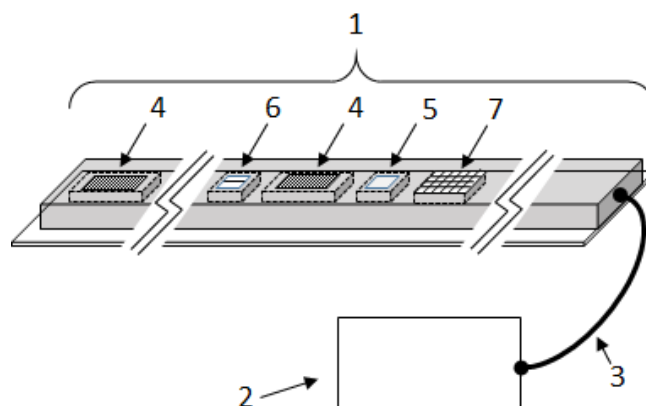

Figure 1: General overview of proposed MOS device showing optical strip (1), control unit (2) and connecting cables (3). Light-emitting elements include LEDs (4) and a laser diode (5). Receiving elements include a sensing photodiode (6) and a matrix detector array (7).

In the following sections, four cases of use are presented: deep-field surgical illumination, optical analysis of materials, inner imaging of cavities and optical control of devices. Background outlines and technology readiness

level (TRL) values are given for each application. This device is currently patent pending (University of Seville, Spain, 2014) [3].

2 APPLICATION TO ILLUMINATION IN DEEP SURGICAL FIELDS

Surgical illumination devices use large-size lamps and headlights, and optical fiber and liquid light guides. They define a directional light beam projected onto the surgical field but instruments and surgeon’s hands generate shadows and irregularly lit areas. Such inhomogeneities affect surgical performance, particularly in deep-field neurosurgery and in minimally invasive procedures. A linear array of high-intensity light emitting diodes (LEDs) in a MOS attached to conventional surgical instruments provides optimized illumination even at the very far end of cavities. Color temperature of emitted light is controlled by the types and modulation of selected LEDs.

A portable, battery-operated MOS system may also be used inside vehicles and in emergency situations. In such applications, current TRL = 5-6.

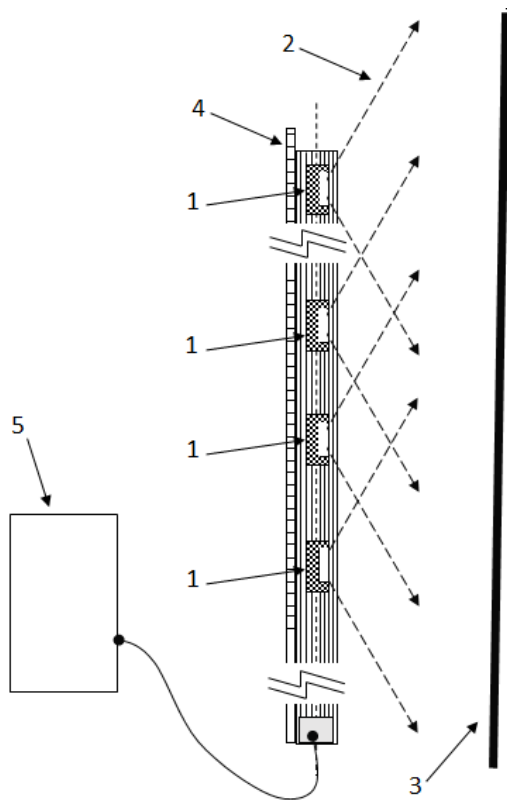

Figure 2: Application of proposed MOS as an illumination device. Each high-intensity LED (1) emits a 120° cone of light (2). For simplicity, the illuminated surface is shown as planar (3). The supporting metal layer (4) drains heat to dissipation elements in the control unit (5).

3 APPLICATION TO OPTICAL ANALYSIS

A combined array of LEDs and receiving photosensors on one or more optical strips allows for obtaining measurements of diffuse reflectance, absorption and fluorescence –static and dynamic– spectra of the walls or the content of the cavity where the MOS device is inserted. The type and modulation of the LEDs define the emitted colors (wavelengths). Comparison with reference values or spectral signatures may identify pollutants and pathogens, especially in optically transparent media in conduits or containers. In this application, current TRL = 3.

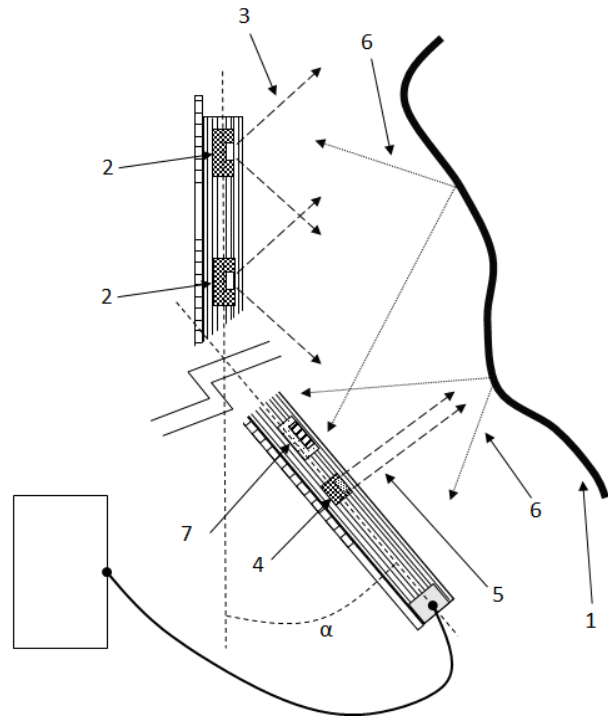

Figure 3: Application of proposed MOS for optical analysis of a surface (1). The optical strip is bended an angle α . Each LED (2) emits a 90° cone of light (3). A laser diode (4) emits a collimated beam (5). Reflected light beams (6) are received by sensing photodiodes (7).

4 APPLICATION FOR IMAGING INSIDE CAVITIES

A MOS structure can combine image sensors with illuminating microLEDs. Active optical elements project illumination beams or patterns of structured light [4] and array sensors –with overlapping micro- and planar lenses– record images. This set-up allows for imaging inside

cavities (Figure 4). Sequential scanning, stereoscopic or panoramic views and other specific reconstructions can be generated from obtained image sets. Attachment of proposed MOS to specific instruments may allow for optical imaging in locations hard to reach with current camera systems. In this application, current TRL = 2.

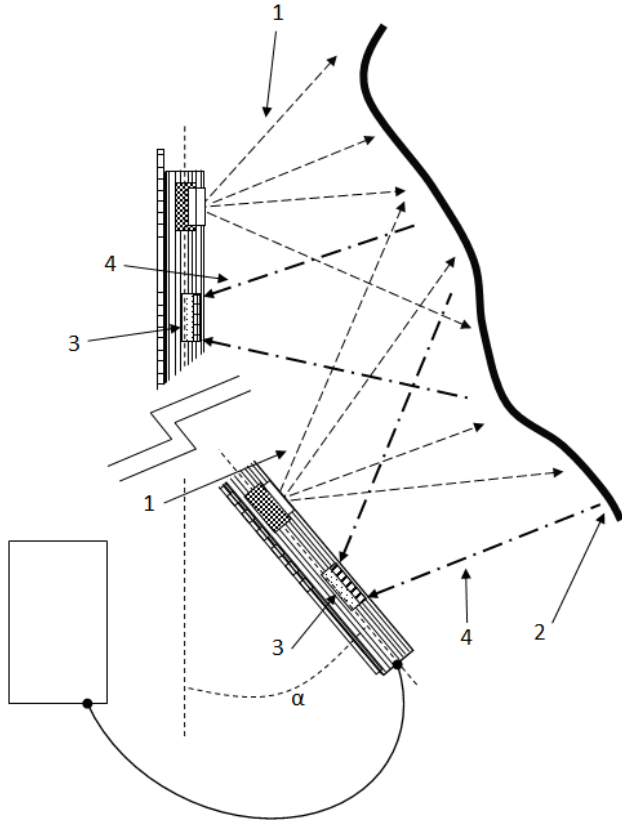

Figure 4: Application of proposed MOS for imaging inside cavities. The optical strip is bended an angle α . Illumination or structured light beams (1) are projected onto the imaged surface (2). Imaging sensors (3) receive reflected beams (4).

5 APPLICATION TO OPTICAL COMMUNICATION AND CONTROL

Optical signals emitted and received by active elements placed on the optical strip of the MOS can be used to control and communicate with other devices (sensors, switches, actuators, and even robots) in the illuminated area (Figure 5).

Light beams emitted from LEDs in the strip can be modulated to carry control signals. Data from sensors can also be sent as optical signals to be received by the optical strip and recorded or further transmitted from the control unit. In this application, current TRL = 2-3.

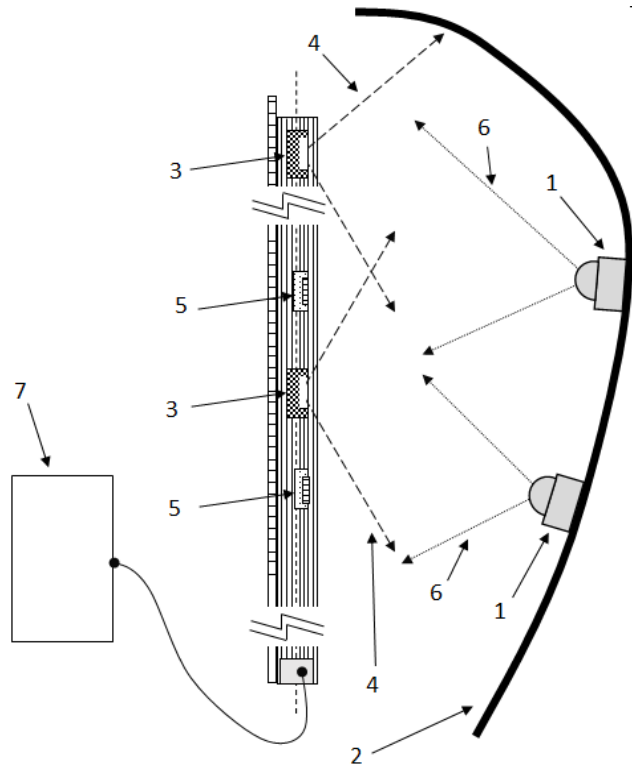

Figure 5: Application of proposed MOS for optical communication and control of devices (1) in cavities (2). LEDs (3) emit modulated light beams (4). Photodiodes (5) receive signals and data (6) from controlled devices (1) and send them to the control unit (7).

REFERENCES

- [1] Milster T.D., "Miniature and micro-optics" in Bass M. et al (eds.), "Handbook of optics", Vol. 2, McGraw-Hill, 7.1-7.33, 1995.
- [2] Schumann M. et al. "Hybrid 2D-3D optical devices for integrated optics by direct laser writing". *Light: Science & Applications*, 3, e175, 2014.
- [3] Gomez-Gonzalez E., "Dispositivo Optico Planar Multicapa", Patent pending, University of Seville, 2014.
- [4] Hayes T., "MicroLEDs emit light in programmable patterns", *OLE*, december, 15-17, 2008.