

## Accepted Manuscript

Oxidative degradation of a novel AMP/AEP blend designed for CO<sub>2</sub> capture based on partial oxy-combustion technology

F. Vega, M. Cano, A. Sanna, J.M. Infantes, M.M. Maroto-Valer, B. Navarrete

PII: S1385-8947(18)31076-3  
DOI: <https://doi.org/10.1016/j.cej.2018.06.038>  
Reference: CEJ 19249

To appear in: *Chemical Engineering Journal*

Received Date: 23 December 2017  
Revised Date: 6 June 2018  
Accepted Date: 8 June 2018

Please cite this article as: F. Vega, M. Cano, A. Sanna, J.M. Infantes, M.M. Maroto-Valer, B. Navarrete, Oxidative degradation of a novel AMP/AEP blend designed for CO<sub>2</sub> capture based on partial oxy-combustion technology, *Chemical Engineering Journal* (2018), doi: <https://doi.org/10.1016/j.cej.2018.06.038>

This is a PDF file of an unedited manuscript that has been accepted for publication. As a service to our customers we are providing this early version of the manuscript. The manuscript will undergo copyediting, typesetting, and review of the resulting proof before it is published in its final form. Please note that during the production process errors may be discovered which could affect the content, and all legal disclaimers that apply to the journal pertain.



## Oxidative degradation of a novel AMP/AEP blend designed for CO<sub>2</sub> capture based on partial oxy-combustion technology

F. Vega<sup>a</sup>, M. Cano<sup>a</sup>, A. Sanna<sup>b</sup>, J. M. Infantes<sup>a</sup>, M. M. Maroto-Valer<sup>c</sup>, B. Navarrete<sup>a</sup>

<sup>a</sup>*Chemical and Environmental Engineering Department, School of Engineering, University of Seville, C/ Camino de los Descubrimientos s/n 41092 Sevilla, Spain, Phone: 954481397, [fvega1@us.es](mailto:fvega1@us.es)*

<sup>b</sup>*Institute of Mechanical, Process and Energy Engineering (IMPEE), School of Engineering & Physical Sciences, Heriot-Watt University, Edinburgh, EH14 4AS, UK*

<sup>c</sup>*Research Centre for Carbon Solutions (RCCS), School of Engineering & Physical Sciences, Heriot-Watt University, Edinburgh, EH14 4AS, UK*

### Abstract

Solvent degradation and volatile compound emissions are two of the major concerns about the deployment of carbon capture technologies based on chemical absorption. In this context, partial oxy-combustion might reduce the solvent degradation due to the use of a higher CO<sub>2</sub> concentrated flue gas. This work evaluates the oxidative degradation of a novel AMP/AEP blend, namely POS #1, under partial oxy-combustion conditions. The effects of temperature and flue gas composition were evaluated in terms of solvent loss, degradation rates, NH<sub>3</sub> emissions and degradation products. The experiments were set at temperatures up to 70 °C and two levels of O<sub>2</sub> concentration – 3%v/v and 6%v/v. The CO<sub>2</sub> concentration of the flue gas ranged between 15%v/v and 60%v/v CO<sub>2</sub>.

The novel solvent POS#1 showed high resistance to degrade and resulted in lower degradation rates than MEA in all the operating conditions evaluated in this work. The maximum degradation of AEP and AMP was 24% and 19%, respectively. MEA degraded almost double under the same conditions. Temperature and O<sub>2</sub> concentration enhanced the oxidative degradation of POS #1. However, the use of higher CO<sub>2</sub> concentration in the flue gas led to lower degradation rates of AEP and AMP and hence oxidative degradation was partially inhibited under partial oxy-combustion conditions. The presence of higher CO<sub>2</sub> content in the flue gas decreased the NH<sub>3</sub> production and a 70% reduction of its emissions was achieved as the CO<sub>2</sub> concentration shifted from 15%v/v to 60%v/v. Other major degradation compounds such as formate and 2,4-lutidine were also decreased. New degradation products were not identified

so that the suggested degradation pathways proposed in the literature were not influenced by the presence of higher CO<sub>2</sub> concentrations.

Keywords: degradation; partial oxy-combustion; solvent; CCS; CO<sub>2</sub> capture

## 1. Introduction

The transition towards a low-carbon energy system relies on improving process efficiency and the deployment of renewable energy production [1]. The energy sector contributes with two-third of the greenhouse gas (GHG) emissions worldwide and the primary energy demand is expected to increase 30% by 2040 [2]. In this framework, carbon capture and storage (CCS) technologies are considered a frontline option to meet the European Commission (EC) 2030 strategy aims (40% reduction of GHG emissions in 2030 compared to the 1990 emission levels) and the reduction targets proposed by the Paris Agreement in last Conference of Parties (COP-21) [3].

Among CO<sub>2</sub> capture technologies, partial oxy-combustion is emerging as a promising approach that might reduce the energy penalties related to the overall CO<sub>2</sub> capture process [4]. It is based on the use of oxygen-enriched air as an oxidizer to produce a higher CO<sub>2</sub> concentrated flue gas that should enhance the CO<sub>2</sub> separation process, typically based on chemical absorption [5]. Partial oxy-combustion can potentially reduce the costs associated to both the high purity O<sub>2</sub> production required from oxy-combustion technology and the CO<sub>2</sub> separation process related to post-combustion technology [6]. According to Favre et al., partial oxy-combustion might achieve a 25% energy reduction of the CO<sub>2</sub> capture process [7].

In addition, solvent degradation, which contributes up to 10% of the total CO<sub>2</sub> capture costs, constrains the development of chemical absorption and its application in CCS technologies [8,9]. Further concerns about emissions of volatile solvents and their reaction to form carcinogens compounds, such as nitramines and nitrosamines in the atmosphere, are currently limiting their use as a CO<sub>2</sub> mitigation approach [10]. Recent studies on monoethanolamine (MEA) degradation showed that the operating conditions derived from partial oxy-combustion can lead to a substantial reduction of both the solvent degradation rates and the emissions of

volatile degradation compounds and solvents under absorption conditions [11]. The presence of elevated CO<sub>2</sub> concentration in the flue gas likely limits the O<sub>2</sub> mass-transfer into the bulk liquid and hence inhibits the encounters between the solvent and O<sub>2</sub> [12].

These main findings described above encourage research to develop new solvent formulations and blends that can improve the overall performance of the CO<sub>2</sub> capture process in terms of faster absorption kinetics, higher CO<sub>2</sub> absorption capacity, lower energy requirements for solvent regeneration and higher resistance to thermal and oxidative degradation [12-15]. Primary amines such as monoethanolamine (MEA) have been proposed to be blended with tertiary amines, showing lower energy requirements during the solvent regeneration stage [16]. Potassium carbonate promoted with piperazine (PZ) and 2-amino-2-methyl-1-propanol (AMP)/PZ blends has also showed further improvements on the absorption kinetics [17, 18]. In this respect, a new solvent blend, namely partial oxy-combustion solvent (POS #1), resulted in a high performance for CO<sub>2</sub> capture under partial oxy-combustion conditions. POS #1 combines AMP with aminoethyl piperazine (AEP) showing an excellent behaviour in terms of absorption kinetics and cyclic CO<sub>2</sub> capacity, particularly at 40%v/v CO<sub>2</sub> concentration in the flue gas [19].

AMP has shown a high resistance to be degraded both thermally and in presence of O<sub>2</sub> [20, 21]. Its resistance is not altered as it is blended with other amino-based solvents [22]. The low degradation rates showed at high temperature make AMP an attractive solvent [23]. Its use should allow to operate the stripping stage at elevated temperatures. Elevated stripping pressure lead to higher stripping temperature, which might reduce further the energy consumption during the regeneration stage [24]. AMP resulted highly resistant to degrade in comparison with other primary amines. It is unlikely possible to abstract one hydrogen atom from the tertiary carbon of the  $\alpha$ -position nitrogen atom due the molecular structure of AMP and hence the formation of radicals via hydrogen abstraction is inhibited [20, 21]. Table 1 summarizes the most relevant degradation compounds reported from the literature. With respect to oxidative degradation compounds, Lepaumier explained that methylation reactions should be a primary degradation

step for AMP degradation [20]. A new degradation pathway has been proposed by Wang and Jens in which AMP may degrade via peroxy radical formation [22].

AEP belongs to piperazines that also showed low degradation rates at temperatures below 150 °C [13]. Although AEP provided an elevated resistance to oxidative degradation, the degradation rates were higher than both aqueous solution of PZ and AEP/PZ blends [25]. The main degradation compounds identified from AEP degradation studies are summarized in Table 2. Most of them were identified from thermal degradation experiments in combination with other solvents. Although here is no specific studies on AEP degradation mechanism, Freeman suggested that AEP is as nucleophile as PZ and hence AEP might attack different protonated AEP to form thermal degradation compounds. Most likely, AEP reacts with protonated either the  $\alpha$ -nitrogen or nitrogen from the primary amino group [26, 27].

Table 1. Main degradation products identified from AMP degradation studies

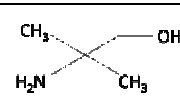

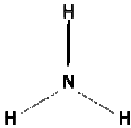
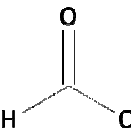
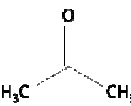
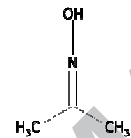
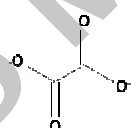
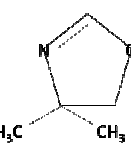
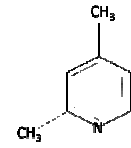
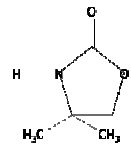

Solvent	Molecule Structure	Molecular Weight	CAS number	Reference
2-amino-2-methyl-1-propanol		89	124-68-5	-

Degradation compound	Molecule Structure	Molecular Weight	CAS number	Reference
Ammonia		17	7664-41-7	[20,21,23]
Formate		45	-	[20,21,23,28]
Acetone		58	67-64-1	[21,23]
Acetone oxime		73	127-06-0	[23]
Oxalate		88	-	[20,21,23]
4,4-dimethyl-2-oxazoline		99	30093-99-3	[23]
2,4-Lutidine		107	108-47-4	[21,23]
4,4-dimethyl-2-oxazolidinone		115	26654-39-7	[20,21,23]

For oxidative degradation pathways, hydrogen abstraction of one of the methylene carbon in the ring is suggested to be the initial step to produce oxidative degradation of AEP. Peroxyl radical

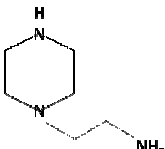
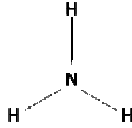
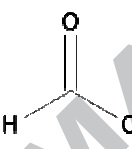
might react in alkaline medium to produce peroxide via intermolecular hydrogen abstraction [27].

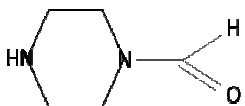
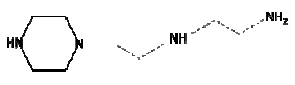
Table 2. Main degradation products identified from AEP degradation studies

Solvent	Molecule Structure	Molecular Weight	CAS number	Reference
1-(2-aminomethyl)piperazine		129	140-31-8	-
Degradation compound	Molecule Structure	Molecular Weight	CAS number	Reference
Ammonia		17	7664-41-7	[13,27]
Formate		45	-	[13]
Piperazine		86	110-85-0	[27,29]
N-formyl piperazine		114	7755-92-2	[13]
1-[2-[(2-aminoethyl)amino]ethyl]piperazine*		129	140-31-8	[13,29]
1,4-piperazinediethanamine*		172	6531-38-0	[13,27,29]
1,1'-(1,2-ethanediyl)bis-piperazine		198	19479-83-5	[13]

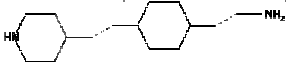
Poly AEP		-	-	[27]
----------	---	---	---	------

This work aims at evaluating the degradation of POS #1 under partial oxy-combustion conditions in order to confirm both the resistance of the AMP/AEP blend under these new operating conditions and the capacities of this technology to decrease solvent degradation. The effects of key operating parameters such as temperature and oxygen concentration are also studied. The degradation of AMP and AEP are further discussed in terms of solvent loss, main degradation compounds, volatile compound emissions and degradation mechanisms.

Although degradation pathways and the most relevant degradation compounds from oxidative degradation of AMP and AEP have been studied at different O<sub>2</sub> partial pressure and temperatures, the effect of CO<sub>2</sub> concentration in the flue gas is still unknown. In this work, the influence of higher CO<sub>2</sub> content in the bulk gas on the degradation product formation will be evaluated and new insights about major degradation products and their possible degradation pathways will be further discussed.

## 2. Experimental procedure

AEP and AMP solvents were supplied by Acros Organics with purity over 99 vol.%. The solution were prepared using deionized water. The synthetic flue gas with different CO<sub>2</sub>/O<sub>2</sub> compositions were provided in 50L-cylinders by Linde. The certificate analysis of the cylinders (DIN EN ISO 6141) guarantees a level of uncertainty of the within +/- 1%. The sulphuric acid required for ammonia emission determination was provided in a 0.1 N aqueous solution format by Panreac with a level of uncertainty within +/- 1%.

In this work, operating parameters such as the absorption temperature, the CO<sub>2</sub> and the O<sub>2</sub> concentration of the synthetic flue gas were studied in order to evaluate their effects on the oxidative degradation behaviour of POS#1 solvent - AEP/AMP blend -. A summary of the ranges evaluated in this work is reported in Table 3. Variations of the CO<sub>2</sub> composition of the synthetic flue gas simulate the different level of oxygen-enriched air used in partial oxy-



combustion capture. Conventional post-combustion capture represents a 15%v/v CO<sub>2</sub> – typically CO<sub>2</sub> composition from air-firing coal combustion [30] – whereas higher CO<sub>2</sub> concentrations imply a higher oxygen content in the oxidizer for partial oxy-combustion operations. The maximum CO<sub>2</sub> concentration studied in this work was 60%v/v CO<sub>2</sub>, corresponding to an 80%v/v oxygen-enriched oxidizer during the combustion process [11]. According to Favre et al., higher values of the oxygen-enriched air should not produce further reductions on the overall energy requirements of the CO<sub>2</sub> capture process under partial oxy-combustion conditions respect to post-combustion and oxy-combustion [7]. In addition, the O<sub>2</sub> concentration varied from 3% v/v to 6% v/v and the operation temperature was evaluated at the operating temperature and the temperature bulge in a conventional CO<sub>2</sub> chemical absorption process - 50°C and 70°C, respectively. Two experiments were conducted at 100 °C to evaluate the oxidative and thermal degradation at elevated temperature. A detailed description of the experimental parameters is reported in previous work [11].

Table 3. Summary of the experimental tests carried out in this work

Parameter	Operating range																	
	15				20				40				60					
CO <sub>2</sub> (%v/v)																		
O <sub>2</sub> (%v/v)	3		6		3		6		3		6		3		6			
Temp (°C)	50	70	50	70	50	70	50	70	50	70	50	70	50	70	100	50	70	100

Figure 1 shows a scheme of the lab-rig used in this work. A detailed description of the lab-rig and the operating procedure can be extracted from previous work [11]. Briefly, the lab-rig consists of a 250-mL semi-batch stirred reactor where the AMP/AEP blend was placed. The initial solvent concentration was 15%p/p AMP and 20%p/p AEP, which is under patent application [31]. As it can be seen in Fig. 1, four experiments could be performed in parallel. Synthetic flue gas was supplied from cylinders and the desired flue gas flow – 0.1 mL/min – was controlled using mass-flow controllers. The synthetic flue gas was saturated in water at the experimental temperature before bubbling it into the reactors. A pair of reactors were placed

into two thermal baths in which the experimental temperature was controlled by PID controllers acting on two electrical resistances sited in the thermal-oil baths. The temperature of the electrical resistances were also controlled to avoid any over temperature mal-function during the tests. Oil was also pumped from the thermal-oil baths into the exhaust gas heat exchangers to maintain the water balance in the system.

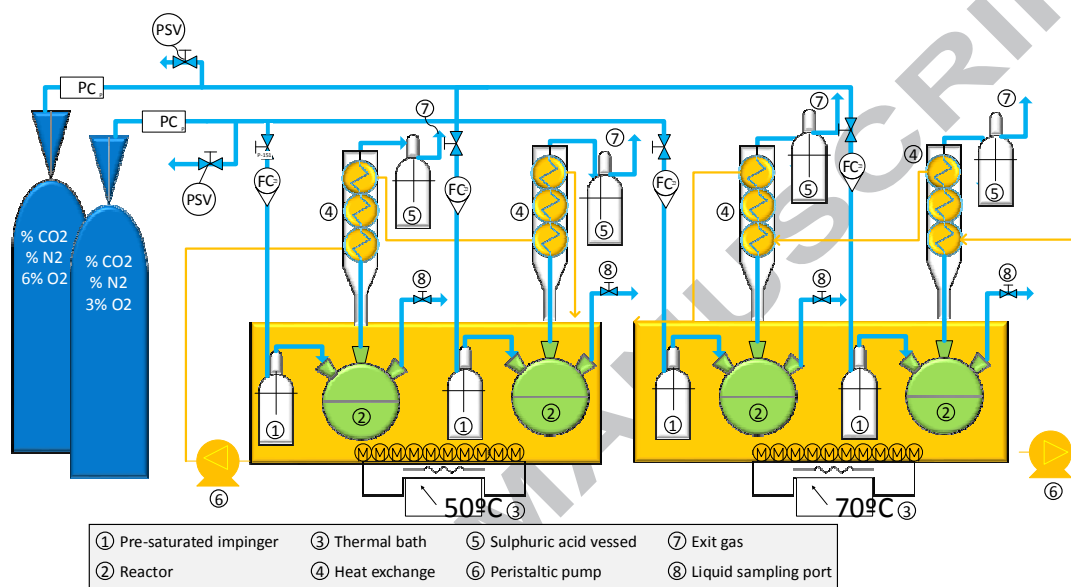

Figure 1. Schematic diagram of the semi-batch amine degradation apparatus

Volatile  $\text{NH}_3$  determinations were performed in accordance with conditional test method 27 (CM-27) using 0.1 sulphuric acid as a reagent. The exhaust gas leaving the reactors was introduced in an impinger, where 100 mL of 0.1N sulphuric acid was previous added [11]. The 0.1 N sulphuric acid solution was recovered several times along the experiment to ensure that enough amount of ammonia over the value of detection limit was provided. AMP/AEP concentration determination and degradation compound identifications were realized from 3-ml liquid samples withdrawn from each reactors at different intervals during the tests.

AMP and AEP concentration was measured using Liquid Chromatography equipped with triple quadrupole and electrospray ion source coupled with Mass Spectrometry (LS/ESI-MS/MS) method. The HPLC-MS/MS equipment was a Waters Xevo TQ-S micro MS coupled with a Waters UPLC Acquity. The separation column used was an Acquity BEH C18 column (50 cm x

2.1 mm), 1.7 microns, using 0.1% formic acid in water as eluent. The flow-rate was set in 0.4 mL/min. Calibration curves were obtained using AMP and AEP standard solutions containing 100, 200, 300, 500, 700 and 1000 ppb for each solvent, separately. Samples were diluted  $1/10^6$  and the injection volume was  $10^{-2}$  ml for the MEA concentration determinations. The  $\text{CO}_2$  loading of each sample was determined using a total organic carbon analyser (TOC), following the procedure described in detail by Chen et al. [32]. The  $\text{CO}_2$  loading of the solvent blend was determined as mole  $\text{CO}_2$  per mole of AMP and AEP in aqueous solution and hence it was expressed as mole  $\text{CO}_2$  per mole solvent.

The identification of the most relevant degradation compounds (Tables 1 and 2) in the liquid samples were performed in an Ultra High Performance Liquid Chromatography (U-HPLC) method. A UHPLC-HR/MS equipment ORBITRAP ELITE MS coupled with Dionex UHPLC was used. The same separation column and the eluents were used as above for AMP and AEP. The method for the identification of each degradation compound was based on a comparison of the theoretical mass of each pseudomolecule ion with the experimental measurement. Samples were diluted  $1/1000$  to be detected with an accuracy below 10 ppm using this method due to the low concentrations in which they were found in the samples.

The ion-ammonium selective electrode from Crison Technologies™ was used for the volatile ammonia determinations. The procedure of this analytical technique is fully described in previous work [11].

### 3. Results and discussion

The degradation of AMP and AEP in a solvent blend, namely POS #1, was studied from both conventional post-combustion and partial oxy-fuel combustion (highly  $\text{CO}_2$  concentrated flue gas up to 60%v/v  $\text{CO}_2$ ) conditions. The results obtained from the experiments described above were further discussed in terms of amine loss, degradation rates and  $\text{NH}_3$  emissions, which is one of the most important oxidative degradation compounds degraded from AMP and AEP

samples. The discussion of the results was also based on the main degradation compounds identified during the experiments and the possible degradation pathways.

In general, POS #1 degraded in lower rates than MEA under similar operating conditions. In the most “extreme run” studied in this work, the amine loss was 24% and 19% at 6%v/v O<sub>2</sub>, 15%v/v CO<sub>2</sub> and 70 °C for AEP and AMP, respectively. MEA degradation was almost double under the same conditions, showing a 38% reduction after 30 days [9]. All the experiments involving AMP and AEP showed lower amine loss compared to MEA. As several authors assessed, the results confirmed that AMP and AEP are more resistant to degrade in conventional post-combustion conditions than MEA [21, 27]. These results also confirm AEP and AMP are more suitable as solvents than MEA for partial oxy-combustion applications.

### 3.1 Effect of CO<sub>2</sub> concentration

The concentration of CO<sub>2</sub> in the flue gas was evaluated from 15%v/v to 60%v/v and its influence on the degradation process of AMP and AEP in the POS #1 blend was discussed. Figures 2a, b, c and d show the amine loss of AMP and AEP during the experiments conducted at 15%v/v and 60%v/v CO<sub>2</sub>. As it can be seen, both solvents degraded at lower rates under higher CO<sub>2</sub> concentration in the flue gas. At 70 °C, the AMP loss was reduced from 19% (6%v/v O<sub>2</sub>) and 9% (3%v/v O<sub>2</sub>) under conventional post-combustion conditions, to 7% and 3% using 60%v/v CO<sub>2</sub> flue gas, respectively. The influence of the presence of more CO<sub>2</sub> in the flue gas (60%v/v) was significantly reduced at 50 °C, where the AMP loss was decreased from 6% (6%v/v O<sub>2</sub>) and 5% (3%v/v O<sub>2</sub>) in post-combustion, to 5% and 4% at 60%v/v CO<sub>2</sub>(Fig. 2c and 2d). AEP also followed a similar behaviour under higher CO<sub>2</sub> concentrated flue gas. The inhibiting effect associated to higher CO<sub>2</sub> concentrated flue gas was more significant in the runs set at 6%v/v O<sub>2</sub> and 70 °C, in which the highest degradation rates were obtained (Fig. 2a and 2b).

The average degradation rates were reduced at higher CO<sub>2</sub> concentrations. In particular, AEP degradation rates were reduced almost to half when 60%v/v CO<sub>2</sub> was used instead of conventional flue gas composition. For example, the experiments conducted at 6%v/v O<sub>2</sub> and 70

°C resulted in a degradation rate of 0.78 mmol/kg/h using 15%v/v CO<sub>2</sub> in the flue gas and in only 0.37 mmol/kg/h when 60%v/v CO<sub>2</sub> was employed. This effect was also observed under intermediate CO<sub>2</sub> concentrations. In the experiments run at 20%v/v and 40%v/v CO<sub>2</sub>, the degradation rates were 0.71 mmol/kg/h and 0.50 mmol/kg/h, respectively.

Similarly, the average degradation rates of AMP were reduced from 0.68 mmol/kg/h to 0.27 mmol/kg/h as the CO<sub>2</sub> concentration increased from 15%v/v to 60%v/v CO<sub>2</sub>. The degradation rates of AMP also decreased under 20%v/v and 40%v/v CO<sub>2</sub>, reporting 0.33 mmol/kg/h and 0.49 mmol/kg/h for each run. Values up to 13 mmol/kg/h AMP degradation rate were reported from experiments conducted at temperatures over 100 °C and O<sub>2</sub> partial pressure of 250 kPa, conditions higher than those used in this work (60 kPa and 70°C) [21]. Other works on AMP/MEA blend produced AMP degradation rates within 0.16 – 2.5 mmol/kg/h in experiments conducted from 80 °C to 120 °C [22]. As it was observed for AEP degradation, the degradation rates of the AMP followed a similar trend with rates lower in presence of higher CO<sub>2</sub> concentration.

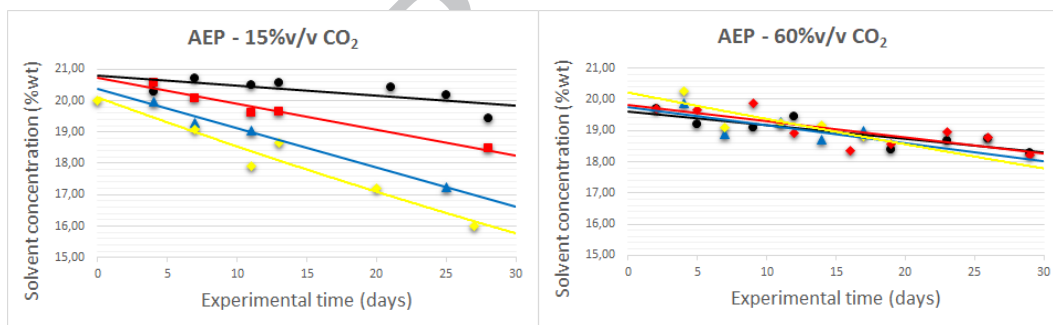

(a)

(b)

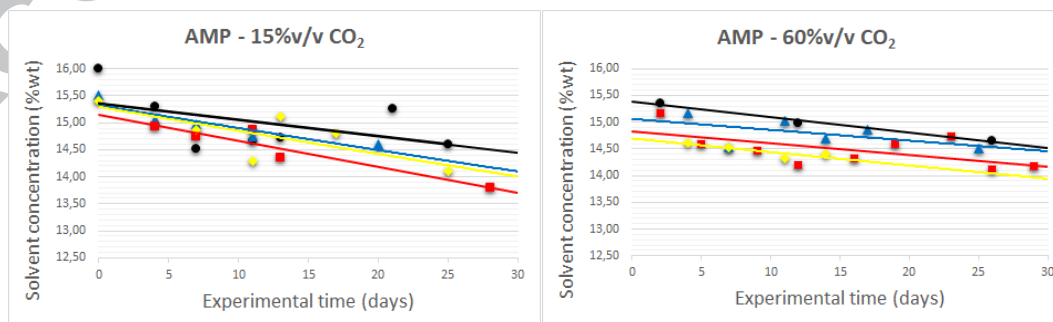

(c)

(d)

Figure 2. Evolution of solvent concentration in aqueous solution during the experiments carried out at: (●) 3%v/v O<sub>2</sub> and 50°C, (■) 6%v/v O<sub>2</sub> and 50°C, (●) 6%v/v O<sub>2</sub> and 70°C, (▲) 3%v/v O<sub>2</sub> and 70°C. Results from post-combustion (15%v/v CO<sub>2</sub>) are represented in (a) AEP and (c) AMP whereas results from 60%v/v CO<sub>2</sub> are represented in (b) AEP and (d) AMP.

The presence of higher CO<sub>2</sub> in the bulk gas had an impact on the degradation mechanism of the solvents. The increase of the CO<sub>2</sub> partial pressure caused the CO<sub>2</sub> loading of the solvent blend to reach higher values. Solvent blends loaded over 0.90 mole CO<sub>2</sub> per mole solvent degraded up to 60% less than low CO<sub>2</sub> loaded solutions (Fig. 3).

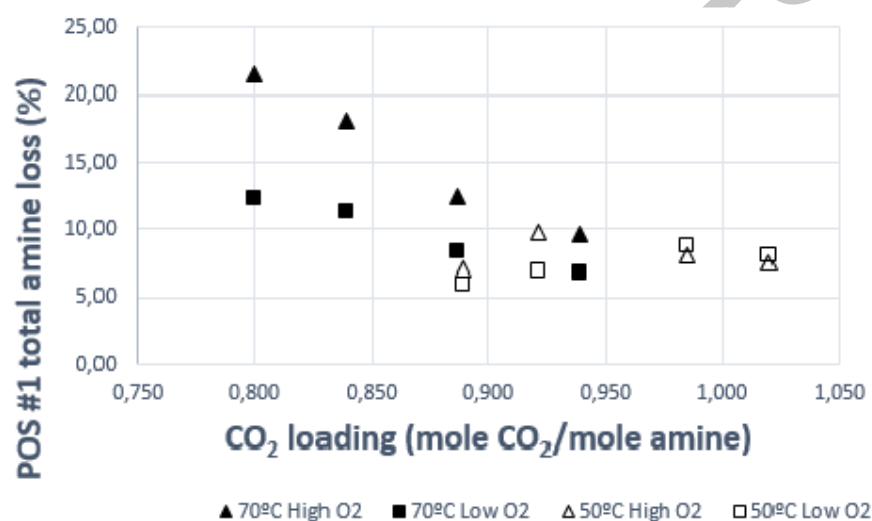

Figure 3. POS #1 loss plotted versus CO<sub>2</sub> loading of aqueous solvent solution

AMP degraded via peroxy radical mechanism (Fig. 4). Wang proposed an intramolecular hydrogen abstraction from either N-H or C-H bond that resulted in imine and enamine formation. Imine is unstable and it decomposes in acetone and ammonia via hydrolysis. In addition, ammonia can be further oxidised to form nitrites and nitrates, whereas acetone degrades in carboxylic acids and aldehydes, mainly formate and formaldehyde. Finally, the formation of 2,4-lutidine can be explained from formaldehyde oxidation into formic acid than later can lead to the imine-enamine equilibrium, which decomposes in this degradation compound.

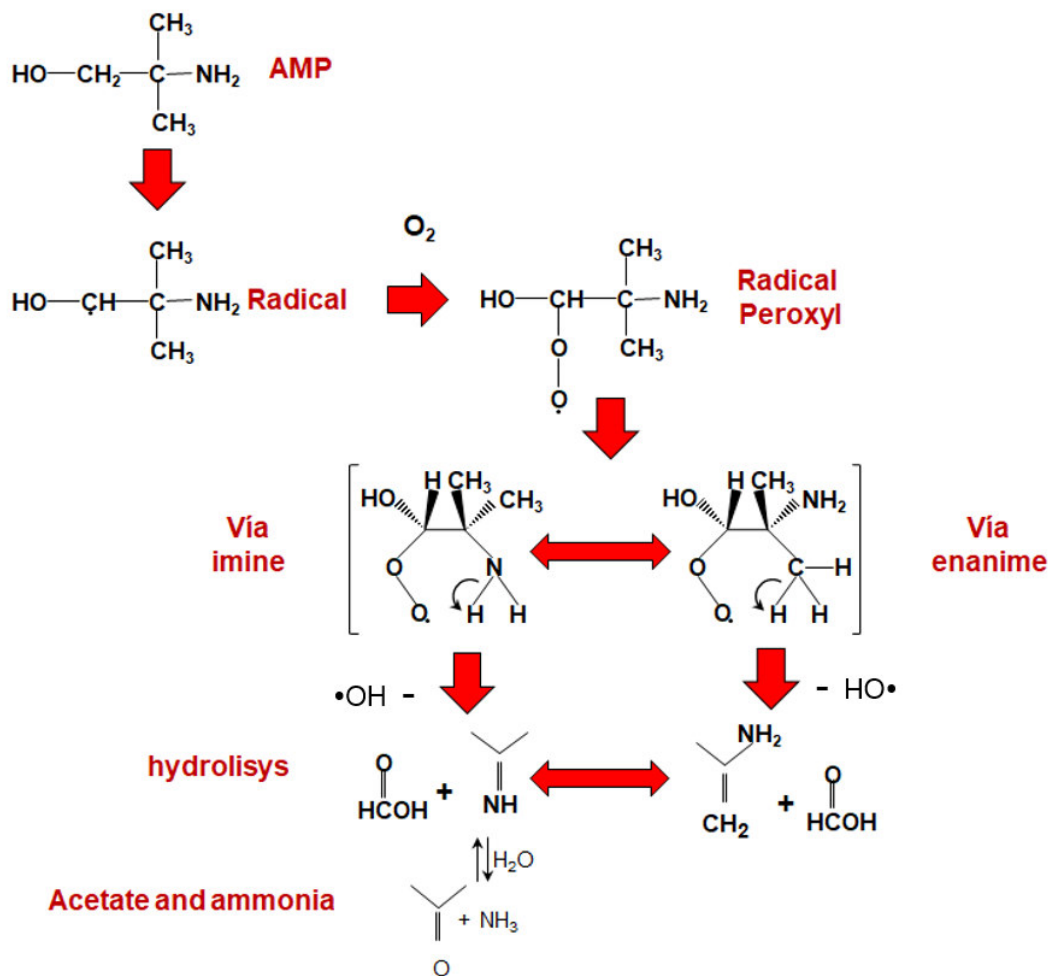

Figure 4. AMP degradation pathway via peroxy radical mechanisms adapted from Wang et al.

[21, 23]

The presence of more AMP carbamate into the bulk liquid decreased the formation of peroxy radical from free non-loaded AMP. The peroxy formation rate is also controlled by the  $O_2$  mass-diffusion into the solvent aqueous solution, which might be limited under elevated  $CO_2$  concentration in the flue gas [21, 23].

In respect of AEP, higher  $CO_2$  in bulk gas results in a higher  $CO_2$  loaded solvent in the solutions reducing the presence of protonated AEP, which is the main precursor of AEP degradation (Fig. 5) [13]. The increase of  $CO_2$  in the bulk gas shifts the equilibrium of  $CO_2$  solubility in the solvent towards higher values. In this work, all the solvents were loaded with more than 0.5 mole  $CO_2$  per mole of solvent. According to Du et al.,  $CO_2$  loadings above 0.3 mole  $CO_2$  per

mole solvent led to lower degradation rates of PZ and this phenomenon was also observed in AEP as a PZ-derived compound [13].

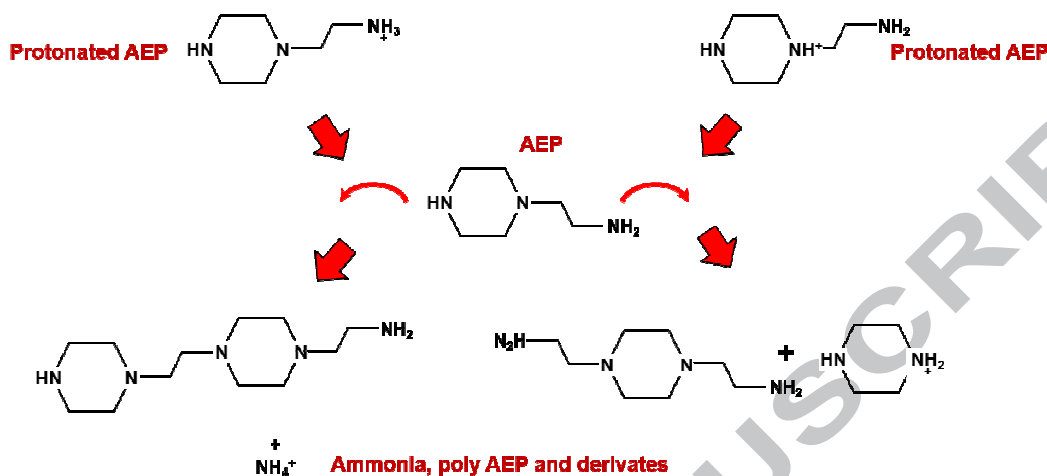

Figure 5. AEP degradation pathway from Du et al. [13] and Freeman and Rochelle [26, 27]

### 3.2 Effect of temperature

Figures 6a and 6b summarize the amine loss in the solvent blend obtained along the experiments carried out at 50 °C and 70 °C using 6%v/v O<sub>2</sub> in the flue gas. At 50 °C, most of the reduction of AMP and AEP concentration was lower than 10% after 30 days, while a previous study showed that MEA lost up to 23% under the same values of both the O<sub>2</sub> concentration and temperature [11]. Therefore, POS #1 provided high resistance to oxidative degradation at 50 °C, showing a high performance in terms of solvent degradation than MEA.

At 50°C, the lowest CO<sub>2</sub> concentration (15%v/v) resulted in a slightly lower amine loss in comparison to the higher CO<sub>2</sub> concentration runs (Fig. 6a). The inhibiting effect of CO<sub>2</sub> in the bulk liquid was reduced at low temperature. Peroxyl formation from AMP and nucleophile attacks between AEP molecules might be reduced at 50 °C. The inhibiting effect associated to higher CO<sub>2</sub> loaded solutions were also decreased. Opposite effects were observed as temperature shifted to 70 °C, as Fig. 6b illustrates. In these runs, the degradation of AMP and AEP was significantly enhanced in comparison with low temperature experiments. Moreover, a clear trend shows that at the same oxygen content in the flue gas, the increase of the CO<sub>2</sub>



concentration results in a decrease of the solvents degradation (Fig. 6a and 6b). As it can be seen in previous Fig. 3, the inhibiting effect of CO<sub>2</sub> concentration should strengthen as temperature increases. Higher temperatures should speed up the C-H cleavage due to vibrating energy accumulation, producing more AMP-derived radicals, which promote AMP degradation [21, 23]. Although more AMP-derived radicals were present in the bulk liquid, the higher CO<sub>2</sub> loaded solution inhibited the formation of peroxy radicals. It should be pointed out that the inhibiting effect associated to the presence of CO<sub>2</sub> in the flue gas decreased as the CO<sub>2</sub> content in the flue gas increased, as it can be extrapolated from the trends observed in Figures 6a and 6b.

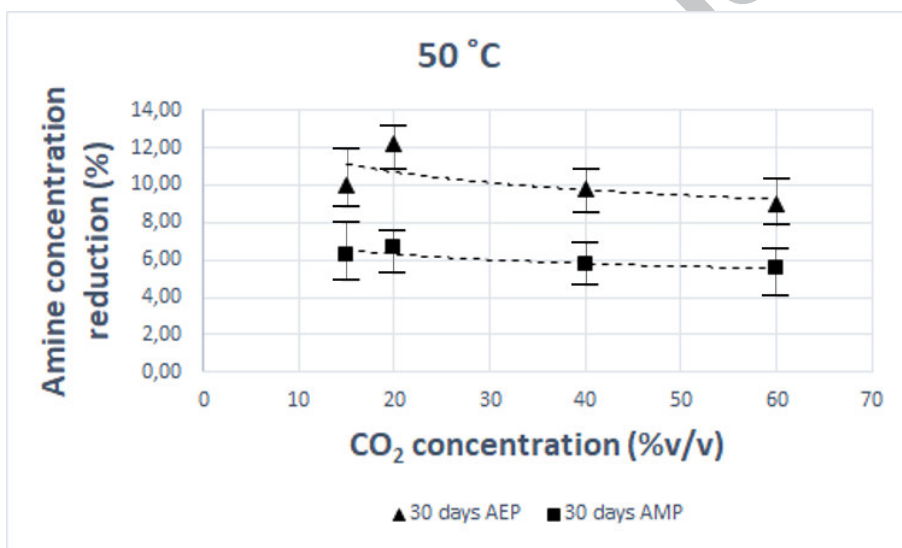

(a)

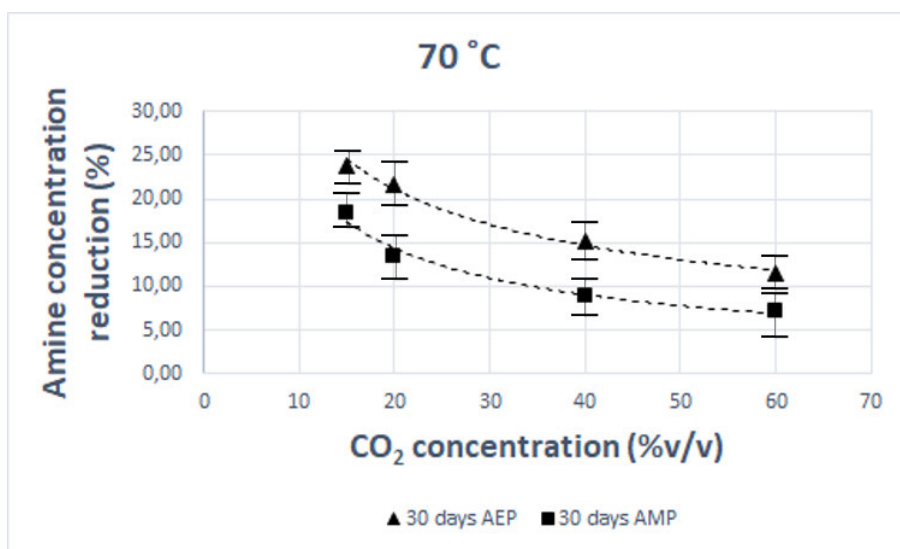

(b)

Figure 6. Solvent loss percentage obtained from experiments run using 6%v/v O<sub>2</sub> and at (a) 50°C and (b) 70°C

The results provided from the high temperature experiments fitted adequately to a first order kinetics. The values of the apparent first order constant ( $k_1$ ) are reported in Table 4. The large difference between the kinetic constant determined in our work and those in literature is due the operating temperature. The references report kinetic constant of thermal degradation occurring at temperatures over 135°C, whereas the maximum temperature studied in this work was 70°C. The latter is the temperature bulge typically reached in a conventional absorber for CO<sub>2</sub> chemical absorption. The increase of temperature from 70 °C to 100 °C produced a substantial increase on AEP degradation, whereas AMP resulted in similar values of  $k_1$  for all the cases, showing a high resistance to thermal degradation. These statements are consistent with other works reported in literature, in which AEP presented low resistance to degradation at temperatures over 100 °C. Instead, AMP provided low values of  $k_1$  at temperatures up to 140 °C, as it can be seen in Table 4.

The difference observed between the studies carried out by Freeman et al. [33] and Wang and Jens [34] might be explained due to the presence of MEA. In the experiments realized by Wang and Jens, a MEA/AMP blend was used, whereas Freeman et al. used AMP in aqueous solution.

The presence of MEA in a MEA/AMP blend partially inhibits the AMP degradation. The same phenomena was observed in this work. The  $k_1$  values obtained for AMP in AMP/AEP blends were similar to these provided in AMP/MEA blends [34].

Table 4. Summary of the experimental tests and kinetic constants carried out in this work

Reference	Temp (°C)	[CO <sub>2</sub> ] (%v/v)	AEP $k_1 / 10^{-7} \text{ s}^{-1}$	AMP $k_1 / 10^{-7} \text{ s}^{-1}$
This work	70	15	1.042	0.579
This work	70	20	0.810	0.694
This work	70	40	0.694	0.347
This work	70	60	0.463	0.231
This work	100	60	2.315	0.926
[33]	135	NAN**	-	2100
[33]	150	NAN**	-	8600
[34]*	100	NAN**	-	1.72
[34]*	120	NAN**	-	3.1
[34]*	140	NAN**	-	6.37
[13]	150	2	36500	-
[13]	175	2	202200	-

\*determined in presence of 2m MEA

\*\*inert N<sub>2</sub>

### 3.3 Effect of O<sub>2</sub> concentration

The O<sub>2</sub> content in the flue gas is critical for the oxidative degradation of solvents, in particular for AMP, which mainly degrades following the peroxy radical mechanism [21, 23]. Higher amount of O<sub>2</sub> in the bulk gas (6% v/v) enhanced the overall degradation process. As it can be seen in table 5, the initial concentration of AEP decreased from 16.58%wt to 15.24%wt after 30 days under 15%v/v CO<sub>2</sub> and 70 °C. AMP concentration varied from 14.13%wt to 12.23%wt under the same experimental conditions. According to Wang et al., the use of higher O<sub>2</sub> partial pressure during the experiments accelerated the degradation rates observed for AMP [21, 23].

The resistance of AMP and AEP to be degraded at high O<sub>2</sub> content was increased in the experiments operated under partial oxy-combustion conditions. The presence of 6%v/v O<sub>2</sub> in the flue gas increased the inhibiting effect associated to higher CO<sub>2</sub> concentration. AEP only degraded up to 17.70%wt using 6%v/v O<sub>2</sub>, 60%v/v CO<sub>2</sub> and 70 °C. This was a 16% increase of the AEP concentration after 30 days in comparison, to the post-combustion run (15%v/v) under

the O<sub>2</sub> concentration (Table 5). In the AMP case, the concentration varied from 13.93%wt to 12.23%wt after 30 days from partial oxy-combustion (60%v/v) to post-combustion conditions (15%v/v), respectively. Therefore, partial oxy-combustion, which results in higher CO<sub>2</sub> concentration in the flue gas, should enhance the POS #1 degradation resistance under oxidative degradation in comparison to conventional post-combustion conditions. The inhibiting effect associated to the higher presence of CO<sub>2</sub> was enhanced at elevated O<sub>2</sub> concentrations in the flue gas.

Table 5. Solvent loss for post-combustion case (15%v/v CO<sub>2</sub>) and partial oxy-combustion case (60%v/v CO<sub>2</sub>) after 30 days

Test Conditions			AEP concentration after 30 days (% wt)	AMP concentration after 30 days (% wt)	AEP solvent loss (%)	AMP solvent loss (%)
O <sub>2</sub> (% v/v)	CO <sub>2</sub> (% v/v)	Temperature (°C)				
3	15	50	19.42	14.78	2.90	1.47
		70	16.58	14.13	17.10	5.80
	60	50	18.36	13.83	8.20	7.80
		70	18.02	14.59	9.90	2.73
		100	18.05	14.11	9.75	5.93
6	15	50	18.47	14.06	7.65	6.27
		70	15.24	12.23	23.80	18.47
	60	50	18.21	14.17	8.95	5.53
		70	17.70	13.93	11.50	7.13
		100	9.99	11.98	50.05	20.13

### 3.4 NH<sub>3</sub> emissions and degradation products

The NH<sub>3</sub> emissions derived from POS #1 degradation were determined at four time intervals during the experiments. Figure 7 summarizes the average NH<sub>3</sub> emission measured for each interval for all the experiments carried out in this work.

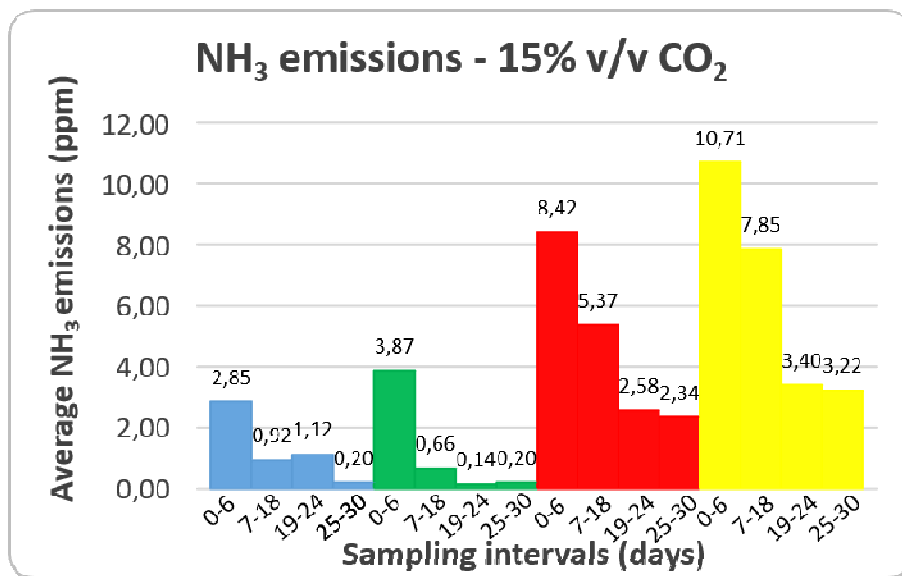

(a)

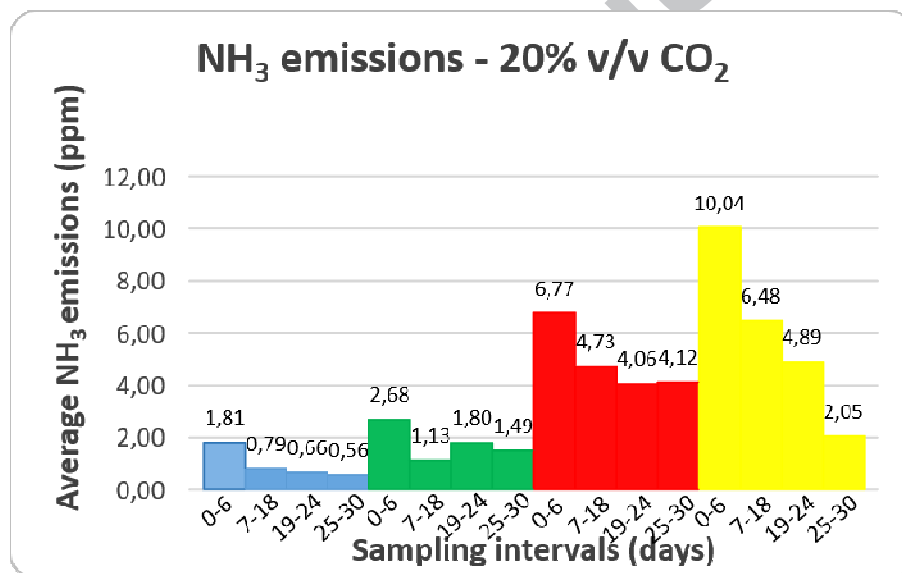

(b)

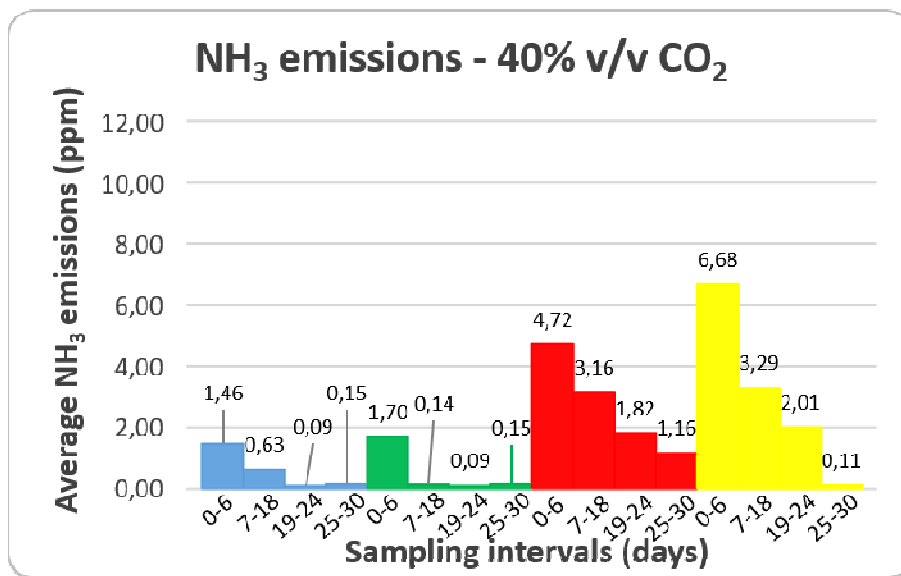

(c)

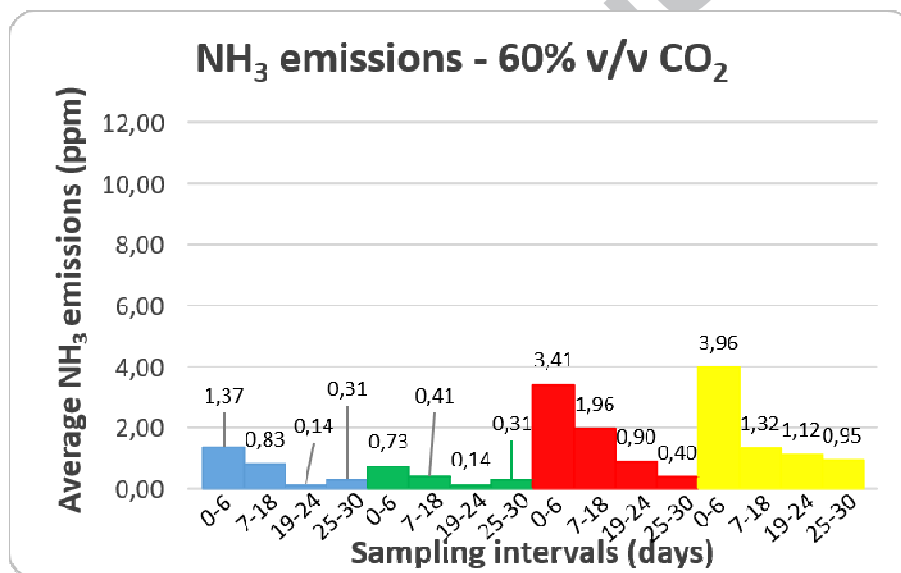

(d)

Figure 7. Evolution of the average NH<sub>3</sub> emissions measured in the lab-rig exhaust gas: (a) 15%v/v CO<sub>2</sub>. (b) 20%v/v CO<sub>2</sub>. (c) 40%v/v CO<sub>2</sub> and (d) 60%v/v CO<sub>2</sub>. The experiments plotted in those figures were set at 3%v/v O<sub>2</sub> and 50°C (blue bars). 6%v/v O<sub>2</sub> and 50°C (green bars). 3%v/v O<sub>2</sub> and 70°C (red bars) and 6%v/v O<sub>2</sub> and 70°C (yellow bars)

NH<sub>3</sub> emissions were dramatically reduced from degraded POS #1 in comparison with MEA. NH<sub>3</sub> emissions over 40 ppm were measured during experiments carried out using MEA as a solvent that were four times those determined for POS #1 worst case. POS #1 produced lower

NH<sub>3</sub> emissions in comparison with MEA under all the operating conditions studied in this work [11].

It should be pointed out that NH<sub>3</sub> emissions were further enhanced at elevated temperature and O<sub>2</sub> content, when it doubled under these conditions. Emissions from experiments run at 50 °C were below 3 ppm as it is shown (in blue and green bars) in Figures 7a, b, c and d. Similar low NH<sub>3</sub> emissions were determined in other experiments with aqueous AMP conducted at 55°C [36]. The inhibiting effect of higher CO<sub>2</sub> concentration in the flue gas are clearly observed in Fig. 7a and 7d. The NH<sub>3</sub> emissions decreased in all the experiments operated under partial oxy-combustion conditions. A 70% reduction of NH<sub>3</sub> emissions were achieved in the 60%v/v CO<sub>2</sub> cases, in comparison to the conventional post-combustion case. Therefore, the results obtained from NH<sub>3</sub> emission measurements confirm that a more CO<sub>2</sub> concentrated flue gas reduces the oxidative degradation of POS #1 – and hence AMP and AEP -.

The solvent loss are represented as function of the total NH<sub>3</sub> emissions obtained from each experiment carried out in this work (Fig. 8). As it occurs in MEA experiments, the degradation of AMP and AEP are closely related to the amount of NH<sub>3</sub> emitted and their measurement can be used for monitoring POS#1 degradation in CO<sub>2</sub> capture by chemical absorption [11]. The dependence of the solvent loss with the total NH<sub>3</sub> production during the experiments showed a linear approximation with R<sup>2</sup> values ranging between 0.75 and 0.85.

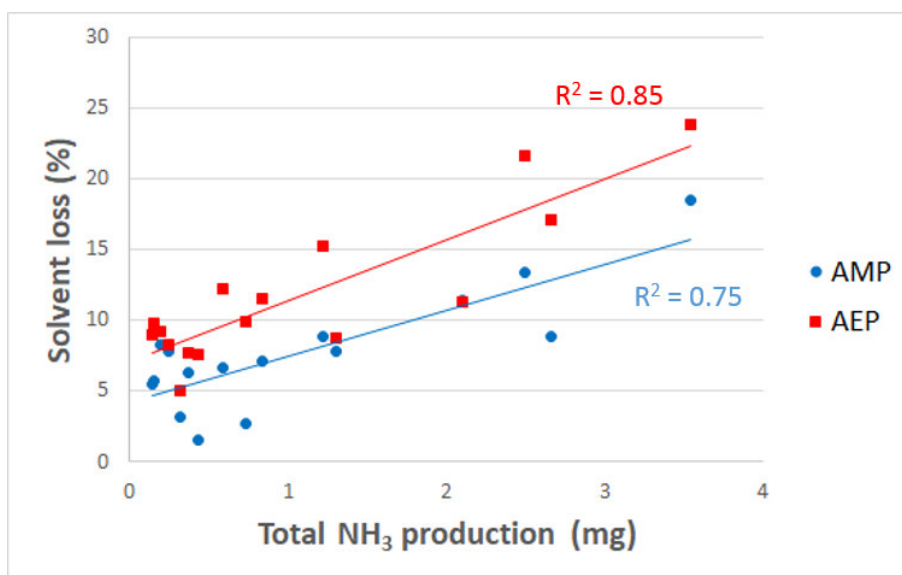

Figure 8. AEP and AMP loss plotted versus the total amount of NH<sub>3</sub> produced.

As expected, the most relevant degradation compounds identified in the experiments were identical to those referenced in the literature (tables 1 and 2). The CO<sub>2</sub> content in the flue gas had no influence on the main degradation pathways suggested in previous studies. Formate was the major degradation compound identified in the liquid samples withdrawn during the experiments. As it occurred to NH<sub>3</sub> formation, higher amounts of formate were formed as O<sub>2</sub> concentration and temperature were increased, but higher CO<sub>2</sub> concentrations decreased its formation mainly due to the inhibiting effect related to O<sub>2</sub> mass-transfer into the bulk liquid. In respect to AMP degradation compounds, 2,4-Lutidine was the major degradation product, particularly at elevated temperatures. The inhibiting effect of CO<sub>2</sub> was also observed in 2,4-Lutidine formation. Other compounds such as acetone and oxazolidinones were also identified. In particular, 4,4-dimethyl-2-oxazolidine (DMOZD) formation was increased under higher CO<sub>2</sub> concentrations, probably due to ring enclosure mechanisms enhancement [21, 23]. Ethylenediamine and oxopiperazines were the major degradation compound derived from AEP degradation and their production was enhanced with increased temperature and CO<sub>2</sub> concentration. Other compounds such as PZ, N,N-dis(2-aminoethyl)piperazine (DAEP) and poly-AEPs were identified mainly in samples at 100 °C. The concentration of these degradation



compounds were found the detection limit of the analytical method used in this work, and therefore, they were not detected in samples withdrawn from experiments conducted at 50 °C.

In general, POS #1 showed a high resistance to the oxidative degradation in both post-combustion and partial oxy-combustion conditions. Although POS #1 degraded less in comparison with MEA in post-combustion tests, the use of oxy-combustion conditions enhanced the POS #1 degradation resistance and reduced by 50% the degradation rates observed in the post-combustion runs. The volatile compounds emissions were also dramatically decreased under these conditions, and therefore, the cost associated to solvent make-up and clean gas treatment should be further decreased using POS #1 and 60%v/v CO<sub>2</sub> flue gas.

#### 4. Conclusions

The evaluation of the degradation behaviour of a novel solvent blend has been performed under partial oxy-combustion conditions in a semi-batch reactor for 30 days. The novel solvent, namely POS #1, consists of an AMP/AEP blend. POS #1 showed high resistance to oxidative degradation at absorber conditions. AMP and AEP loss were 19% and 24%, respectively, almost half compared to 38% reduction for MEA at conventional post-combustion conditions. Among the two solvents, AMP showed a high performance providing lower amine loss than AEP, in particular during high temperature experiments. Experiments conducted at higher CO<sub>2</sub> concentration demonstrated that partial oxy-combustion reduces the oxidative degradation of POS #1. The use of a more CO<sub>2</sub> concentrated flue gas partially inhibits the oxidative degradation of the AMP/AEP blend, reducing half the degradation rates observed under post-combustions conditions. The increase of the CO<sub>2</sub> partial pressure causes the CO<sub>2</sub> loading of the solvent blend reaches higher values. The presence of more AMP carbamate into the bulk liquid decreased the formation of peroxy radical from free non-loaded AMP. In respect to AEP, higher CO<sub>2</sub> in bulk gas produces more CO<sub>2</sub> loaded solutions and limited the presence of protonated AEP in the solution.

In terms of degradation compounds, NH<sub>3</sub> emissions experienced a 70% decrease as CO<sub>2</sub> concentration increased from 15%v/v to 60%v/v. POS #1 resulted in four times lower volatile

compound emissions in comparison with MEA experiments under similar conditions. The results suggests that the presence of higher CO<sub>2</sub> in flue gas had no impact on the degradation pathways, but affected the formation rate of the degradation products.

The use of POS #1 combined with partial oxy-combustion producing 60%v/v flue gas might lead to further reductions of the overall CO<sub>2</sub> capture costs. The lower solvent degradation and volatile compound emissions should reduce the requirements of a CO<sub>2</sub> capture process in terms of solvent make-up and the volatile compound abatement.

### **Acknowledgements**

This work was carried out with the financial support of the Ministry of Economy and Competitiveness of the Spanish Government (OXYSOLVENT Pro.; ref: CTM-2014-58573-R) co-financed by the European Development Research Fund (EDRF) From European Union.

### **References**

- [1] European Commission, A policy framework for climate and energy in the period from 2020 to 2030, 2014.
- [2] International Energy Agency, World Energy Outlook 2016. Executive Summary, 2016.
- [3] J. Yan, Carbon capture and storage (CCS), Appl. Energy 148 (2015) A1-A6.
- [4] F. Vega, M. Cano, L.M. Gallego, S. Camino, J.A. Camino, B. Nevarrete, Evaluation of MEA 5 M performance at different CO<sub>2</sub> concentrations of flue gas tested at a CO<sub>2</sub> capture lab-scale plant, Energy Proc. 114 (2017) 6222-6228.
- [5] A. Doukelis, I. Vorrias, P. Grammelis, E. Kakaras, M. Whitehouse, G. Riley, Partial O<sub>2</sub>-fired coal power plant with post-combustion CO<sub>2</sub> capture: A retrofitting option for CO<sub>2</sub> capture ready plants, Fuel 88 (2009) 2428–2436.

- [6] Y. Huang, M. Wang, P. Stephenson, S. Rezvani, D. McIlveen-Wright, A. Minchener, N. Hewitt, A. Dave, A. Fleche, Hybrid coal-fired power plants with CO<sub>2</sub> capture: A technical and economic evaluation based on computational simulations, *Fuel* 101 (2012) 244–253.
- [7] E. Favre, R. Bounaceur, D. Roizard, A hybrid process combining oxygen enriched air combustion and membrane separation for post-combustion carbon dioxide capture, *Sep. Purif. Technol.* 68 (2009) 30–36.
- [8] E.S. Rubin, A.B. Rao, A technical, economic and environmental assessment of amine-based CO<sub>2</sub> capture technology for power plant greenhouse gas control, *Environ. Sci. Technol.* 36 (2002) 4467–4475.
- [9] M. Wang, S.J. Atuman, C. Ramshaw, D. Eimer, N.M. Musa, Process intensification for post-combustion CO<sub>2</sub> capture with chemical absorption: A critical review, *Appl. Energy* 158 (2015) 275-291.
- [10] X. Chen, G. Huang, C. An, Y. Yao, S. Zhao, Emerging N-nitrosamines and N-nitramines from amine-based postcombustion CO<sub>2</sub> capture – A review, *Chem. Eng. J.* 335 (2018) 921-935.
- [11] F. Vega, A. Sanna, M.M. Maroto-Valer, B. Navarrete, V.J. Cortés, Study of the MEA degradation in a CO<sub>2</sub> capture process based on partial oxy-combustion approach, *Int. J. Greenhouse Gas Control* 54 (2016) 160-167.
- [12] A. Sanna, F. Vega, B. Navarrete, M.M. Maroto-Valer, Accelerated MEA degradation study in hybrid CO<sub>2</sub> capture system, *Energy Proc.* 63 (2014) 745-749.
- [13] Y. Du, Y. Wang, G.T. Rochelle, Piperazine/4-hydroxy-1-methylpiperidine for CO<sub>2</sub> capture, *Chem. Eng. J.* 307 (2017) 258-263.

- [14] J.M. Kang, A. Murnandari, M.H. Youn, W. Lee, K.T. Park, Y.E. Kim, H.J. Kim, S.P. Kang, J.H. Lee, S.K. Jeong, Energy-efficient chemical regeneration of AMP using calcium hydroxide for operating carbon dioxide capture process, *Chem. Eng. J.* 335 (2018) 338-344.
- [15] X. Zhang, X. Zhang, H. Liu, W. Li, M. Xiao, H. Gao, Z. Liang, Reduction of energy requirement of CO<sub>2</sub> desorption from a rich CO<sub>2</sub>-loaded MEA solution by using solid acid catalysts, *Appl. Energy* 202 (2017) 673-684.
- [16] W.J. Choi, J.B. Seo, S.Y. Jang, J.H. Jung, K.J. Oh, Removal characteristics of CO<sub>2</sub> using aqueous MEA/AMP solutions in the absorption and regeneration process, *J. Environ. Sci.* 21 (2009) 907-13.
- [17] J.T. Cullinane, G.T. Rochelle, Carbon dioxide absorption with aqueous potassium carbonate promoted by piperazine, *Chem. Eng. Sci.* 59 (2004) 3619-30.
- [18] D. Tong, G.C. Maitland, M.J.P. Trusler, P.S. Fennell, Solubility of carbon dioxide in aqueous blends of 2-amino-2-methyl-1-propanol and piperazine, *Chem. Eng. Sci.* 101 (2013) 851-64.
- [19] F. Vega, B. Navarrete, M. Cano, E. Portillo, Development of partial oxy-combustion technology: new solvents applied to CO<sub>2</sub> capture in fossil-fuels power plants, *Energy Proc.* 63 (2014) 484-489.
- [20] H. Lepaumier, D. Picq, P.L. Carrette, New amines for CO<sub>2</sub> Capture. II. Oxidative degradation mechanisms, *Ind. Eng. Chem. Res.* 48 (2009) 9068-9075.
- [21] T. Wang, K.J. Jens, Oxidative degradation of aqueous 2-amino-2-methyl-1-propanol solvent for postcombustion CO<sub>2</sub> capture, *Ind. Eng. Chem. Res.* 51 (2012) 6529-6536.

- [22] T. Wang, K.J. Jens, Oxidative degradation of aqueous PZ solution and AMP/PZ blends for post-combustion carbon dioxide capture, *Int. J. Greenhouse Gas Control* 24 (2014) 98-105.
- [23] T. Wang, K.J. Jens, Towards an understanding of the oxidative degradation pathways of AMP for post-combustion CO<sub>2</sub> capture, *Int. J. Greenhouse Gas Control* 37 (2015) 354-361.
- [24] G.T. Rochelle, Thermal degradation of amines for CO<sub>2</sub> capture, *Curr. Opin. Chem. Eng.* 1 (2012) 183–190.
- [25] A.K. Voice, H. Li, O. Namjoshi, T. Nguyen, Y. Du, G.T. Rochelle, Amine blends using concentrated piperazine, *Energy Proc.* 37 (2013) 353-369.
- [26] S.A. Freeman, Thermal degradation and oxidation of aqueous piperazine for carbon dioxide capture, Thesis, University of Texas, Austin, Texas, USA, 2011.
- [27] S.A. Freeman, G.T. Rochelle, Thermal degradation of aqueous piperazine for CO<sub>2</sub> capture: 2. Product types and generation rates, *Ind. Eng. Chem. Res.* 51 (2012) 7726-35.
- [28] A.J. Sexton, Amine oxidation in CO<sub>2</sub> capture process, Thesis, University of Texas, Austin, Texas, USA, 2008.
- [29] J.D. Davis, Thermal degradation of aqueous amines used for carbon dioxide capture amine, Thesis, University of Texas, Austin, Texas, USA, 2009.
- [30] DOE-NETL, Cost and performance for low-rank pulverized coal oxy-combustion energy plants. Report n° 401/093010, 2010.
- [31] Patent application, Composición acuosa absorbente, Reference P201601110, 2016.

- [32] E. Chen, Carbon dioxide absorption into piperazine promoted potassium carbonate using structured packing, Thesis, University of Texas, Austin, Texas, USA, 2007.
- [33] S.A. Freeman, J. Davis, G.T. Rochelle, Degradation of aqueous piperazine in carbon dioxide capture, *Int. J. Greenhouse Gas Control* 4 (2010) 756–761.
- [34] T. Wang, K.J. Jens, Oxidative degradation of AMP/MEA blends for post-combustion capture, *Energy Proc.* 37 (2013) 306-313.

**Highlights**

- A novel solvent showed high resistance resulting in lower degradation rates than MEA
- The AEP and AMP loss was half than MEA under the same operating conditions
- Higher CO<sub>2</sub> concentrations partially inhibited the degradation of the AMP/AEP blend
- NH<sub>3</sub> emissions were decreased up to 70% under partial oxy-combustion conditions
- NH<sub>3</sub> emission measurements can be used for monitoring solvent degradation