



Study and Design of a Compact Parallel Coupled Microstrip Band-Pass Filter for a 5 GHz Unlicensed Mobile WiMAX Networks

¹A. Naghar, ¹O. Aghzout, ²F. Medina, ³M. Alaydrus, ⁴M. Essaïdi

¹FS, ENSA, Abdelmalek Essaïdi University, Tetouan, Morocco

²Microwave Group, University of Seville, Spain

³Faculty of Computer Sciences, Mercu Buana University, Indonesia

⁴ENSIAS, Mohamed V-Souissi, Rabat, Morocco

ABSTRACT

In this paper, a compact parallel coupled microstrip band-pass filter (BPF) is used to design a wideband third order of the Tschebyshev elements for an unlicensed WiMAX technology. Some techniques based on the parametrical study are proposed to obtain the desired 10 % operating bandwidth filter response. The new filter is implemented on Arlon AR 1000 substrate having a relative permittivity of 10 and substrate thickness 1.1938 mm respectively. The results based on the transmission line theory approach and the commercial electromagnetic Agilent ADS and CST-MS simulators show a good agreement.

Keywords: *Parallel Coupled Lines, Microstrip filter, Band-pass Filter, Unlicensed WiMAX.*

1. INTRODUCTION

With the continuous advancement in telecommu-nications engineering, the coupled microstrip filters are extensively used as BPF [1]. Due to their relatively weak coupling, this type of filter has narrow fractional bandwidth but instead has desired advantages such as low cost fabrication, simple designing procedure, higher capacities and easy integration [2]. The frequency range of 2 GHz to 11 GHz is divided into three different radio frequency bands, 2.5GHz and 3.5GHz for licensed bands and 5.8GHz for unlicensed ones, each of which has unique processing requirements that are incompatible with the other frequency bands [3]. The result will allow manufacturers of RF components and test equipment to have their products used for multitude employment [4]. The Worldwide Inter-operability for Microwave Access (WiMAX) is an air interface telecommunications technology for combined fixed, portable and mobile broadband wireless access [5], and is based on the IEEE 802:16d 2004 (Fixed WiMAX) and IEEE 802:16e 2005 (Mobile WiMAX) standards [6,7]. Providing a high transfer of data with a potential of replacing a number of existing telecommunications infrastructures [8]. In this paper, the design of a 3rd order of the Tschebyshev compact parallel-coupled microstrip band-pass filter centered at 5.8GHz with required bandwidth up to a 10% for WiMAX transmitters/receivers is presented. The design is based on the use of half wave long resonators and admittance inverters. As a background, designing equations for the coupled line parameters such as can be found in many previous works [9,10]. In this way, following a well-defined systematic procedure, the required microstrip filter parameters can be easily derived

for Chebyshev prototypes [11]. The achieved filter schematic and layout simulation results obtained by the commercial electromagnetic simulators Agilent ADS and CST-MW are presented and discussed.

2. FILTER DESIGN PROCEDURE

2.1 Transmission Line Theory Approach

BP Chebyshev Filter of $\Delta = 10\%$ and Ripple 0.1 dB Substrate With $\epsilon_r = 10$ and $h = 1.1938$ mm

In order to design the filter, first of all, let us determine some specification such as the order number and the operating frequency range of the filter under study. We consider, the simple case of a BPF centered at 5 GHz, having a bandwidth $\Delta = 10\%$ and order $n=3$. The substrate has relative dielectric permittivity $\epsilon_r = 10$ and thickness $h = 1.1938$ mm. Based on the design specification, a 3rd order filter is required for unlicensed WiMAX [4]. The corresponding element values $g_1=1.0316$, $g_2=1.1474$, $g_3=1.0316$ and $g_4=1.0000$, with $g_0=1$ for the third order Tschebyshev response using 0.1 dB of ripple low-pass prototype [12], can be easily obtained from [1,2,9]. The band-pass having a bandwidth of $\Delta = 10\%$ can be obtained by using the fractional bandwidth $\Delta = (\omega_H - \omega_L)/\omega_0$. The purpose of the fractional bandwidth calculation is to allow us the computation parameters such as first, intermediate and the final coupler. The next step is to calculate the even and the odd characteristic line impedances Z_{0e} and Z_{0o} . In order to obtain the expressions of Z_{0e} and Z_{0o} , we used the expressions:

$$Z_{oe\ j,j+1} = Z_0[1 + Z_0 J_{j,j+1} + (Z_0 J_{j,j+1})^2] \quad (1)$$

$$Z_{oo\ j,j+1} = Z_0[1 - Z_0 J_{j,j+1} + (Z_0 J_{j,j+1})^2] \quad (2)$$

Where $Z_0 = 50$ and $Z_0 J_{j,j+1} = \frac{\Delta\pi}{2\sqrt{g_{t,t+1}}}$, [13,14].

Not that, as was predicted, for $n = 1,4$ and $n = 2,3$ the values of Z_{0e} and Z_{0o} , and $C(\text{dB})$ are identical due to the symmetry of the feature structure under study, C is the coupling factor in dB (for $n = 1,4$: $Z_{0e} = 60.719$, $Z_{0o} = 42.573$ and $C(\text{dB}) = -15.1055$ for $n = 2,3$: $Z_{0e} = 51.61$, $Z_{0o} = 48.4875$ and $C(\text{dB}) = -30.1186$. The next step of the filter design is to find the dimensions of coupled microstrip lines that exhibit the desired even and odd mode impedances [15]. Firstly, we determine the equivalent single microstrip shape ratios $(w/h)_s$. Then it can relate coupled line ratios to single line ratios. For a single microstrip line, the even and odd single characteristic impedances are:

$$Z_{0se} = \frac{(Z_{0e})_{j,j+1}}{2} \quad (3)$$

$$Z_{0so} = \frac{(Z_{0o})_{j,j+1}}{2} \quad (4)$$

With the given $\epsilon_r = 10$ and $Z_0 = 50$. Using the single line equations, $(w/h)_{se}$ and $(w/h)_{so}$ can be found from (3) and (4). Such as a result $w/h = 1.14/1.1938$, is approximately 0.955, (Fig.1). In this way, we have chosen the convenient expressions corresponding to the case $(w/h \leq 2)$:

$$\frac{w}{h} = \frac{8e^A}{e^{2A} - 2} \quad (5)$$

With

$$A = \frac{Z_c}{60} \left[\frac{\epsilon_r + 1}{2} \right]^{0.5} + \frac{\epsilon_r - 1}{\epsilon_r + 1} \left[0.23 + \frac{0.11}{\epsilon_r} \right] \quad (6)$$

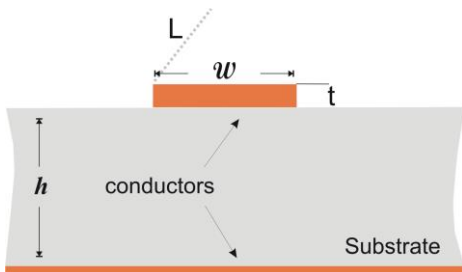

Figure 1: Cross-section of the microstrip structure

At that point, it's able to find $(w/h)_{se}$ and $(w/h)_{so}$ by applying Z_{se} and Z_{so} (as Z_c) to the single line microstrip

equations. Now it comes to a point where it reach the (w/h) and (s/h) for the desired coupled microstrip line, using a family of approximate equations as follows [20]:

$$\frac{s}{h} = \frac{2}{\pi} \cosh^{-1} \left[\frac{\left(\cosh\left(\frac{\pi}{2}\right)\left(\frac{w}{h}\right)_{se} + \cosh\left(\frac{\pi}{2}\right)\left(\frac{w}{h}\right)_{so} - 2 \right)}{\left(\cosh\left(\frac{\pi}{2}\right)\left(\frac{w}{h}\right)_{so} - \cosh\left(\frac{\pi}{2}\right)\left(\frac{w}{h}\right)_{se} \right)} \right] \quad (7)$$

$$\frac{w}{h} = \frac{1}{\pi} \cosh^{-1} \left[\frac{\left(\frac{1}{2} \right) \left(\cosh\left(\frac{\pi}{2}\right)(s/h) - 1 \right) + \left(\cosh\left(\frac{\pi}{2}\right)(s/h) + 1 \right) \cosh\left(\frac{\pi}{2}\right)\left(\frac{w}{h}\right)_{se}}{-\left(\pi/2\right)(s/h)} \right] \quad (8)$$

In order to illustrate the use of the proposed structure and the design procedure, there are a number of formulas, listed for the calculation of the effective dielectric constant:

$$\epsilon_{eff} = \frac{\epsilon_r + 1}{2} + \frac{\epsilon_r - 1}{2} \frac{1}{\sqrt{1 + \frac{12h}{w}}} \quad (9)$$

the most basic one is given by [9]. Once the effective dielectric constant of a microstrip is determined, the guided wavelength of the quasi-TEM mode of microstrip is given by $\lambda_g = \lambda_0 / \sqrt{\epsilon_{eff}}$, where λ_0 is the wavelength of the free space. We have made use of the well-known formula relating the length of the line section with the value of the effective dielectric constant and the guided wavelength,

$$l = \lambda_g / 4 = c / 4f \sqrt{\epsilon_{eff}} \quad (10)$$

where c and f are the central frequency and the speed of light in vacuum respectively. Using the design equations for coupled microstrip lines given by (7) and (8) and based on the even and odd mode characteristic impedances obtained previously, the width and spacing for each pair of quarter-wavelength coupled sections numerically computed are given by: $w = 1.246 \text{ mm}$, $l = 4.986 \text{ mm}$ and $s = 0.454 \text{ mm}$ for the section 1 and 4, and $w = 1.597 \text{ mm}$, $l = 4.931 \text{ mm}$ and $s = 1.685 \text{ mm}$ for the section 2 and 3.

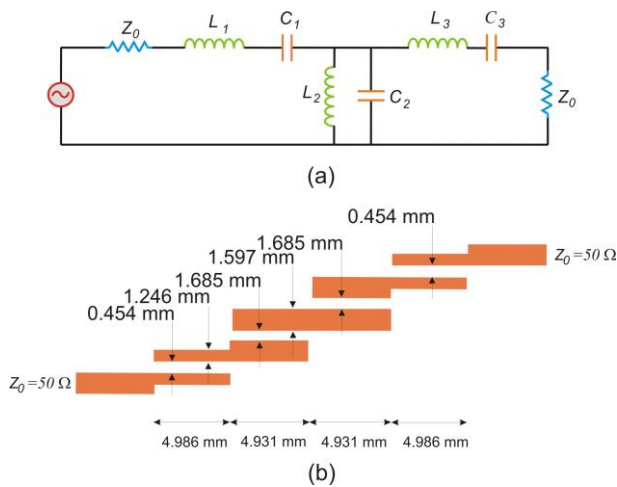

Figure 2: (a): Series lumped equivalent circuit for derivation of design equations for a coupled line BPF. (b) : Layout of the parallel-coupled BPF designed filter proposed in this paper

In Fig. 2, we show a final filter layout with all the determined dimensions calculated previously with its corresponding lumped equivalent circuit. Note that the L 's and C 's are determined from the element values of a lumped-element low pass prototype which has been impedance scaled and frequency transformed to a band-pass filter. For a band-pass filter, low-pass prototype series inductor converts into a series LC circuit, whereas a shunt capacitor converts into a shunt LC circuit,

$$C_i = \begin{cases} \text{Shunt element} \\ g_i / \omega_o \Delta Z_o \\ \text{Series elements} \\ \Delta / \omega_o g_i Z_o \end{cases}, L_i = \begin{cases} \text{Shunt element} \\ \Delta Z_o / \omega_o g_i \\ \text{Series elements} \\ g_i Z_o / \Delta \omega_o \end{cases} \quad (11)$$

A Z-matrix was then obtained for each coupled section and converted to the ABCD equivalents. These ABCD matrices were multiplied to obtain the overall transmission matrix. After coding all obtained formulas, the results based on the coupling matrix concept are shown in Fig. 3.

As was predicted the simulation gave a center frequency of 5.78 GHz. To validate and complete the described study, we consider the important design parameters such as the dispersion effect, microstrip losses, enclosure effect, bandwidth and power handling capability. In order to check the theoretical considerations above, the goal of the next section is to study numerically the behavior of several electrical parameters of the coupled microstrip BPF using the EM commercial Agilent ADS and CST-MW Studio simulators.

The optimization strategy has been accelerated taking into account, that for a given value of floating conductor width w_f , the bandwidth Δ is mainly controlled by strip

width w , strip length l and strip separation s [16,17] and [18].

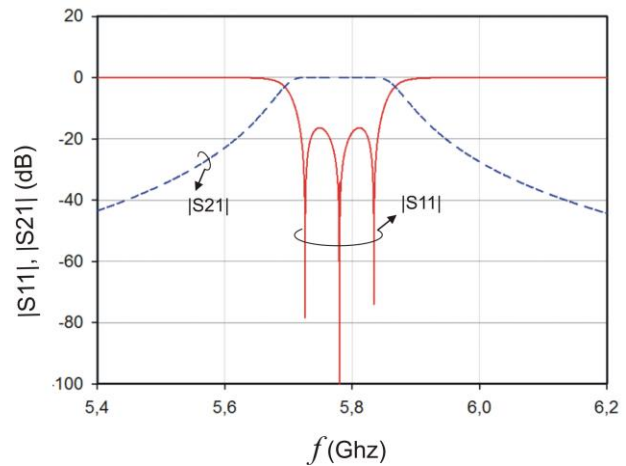

Figure 3: Results obtained with the transmission line theory approach code for the conventional filter of the Fig. 2

2.2 Agilent ADS Simulation

BP Chebyshev Filter of $\Delta = 10\%$ and Ripple 0.1 dB Substrate With $\epsilon_r = 10$ and $h = 1.1938$ mm

A 3rd order parallel-coupled band-pass filter is setup using a commercial electromagnetic simulator (ADS) to study the effect of the different parameters of the coupled lines Fig.4. The result of the designed microstrip filter shows that the center frequency of the filter has deviated from the specified and desired frequency 5.78 GHz, consequently an optimization of the geometrical parameters is necessary.

Note that we dispose of several parameters to vary these geometrical parameters affect the characteristics of BPF design. As a rule, the length, width and gap of the strips can be calculated by a simple procedure based on the EM Commercial simulators (linecalc) [19] but the results show that the values obtained are always deviated from the desired ones. In this way, we have thought to implement some techniques to determine the final design parameters for the filter geometry that we are studying.

In this design, the filter is symmetrical geometrically, indeed only two group of different values are needed to determined during the optimization which are set to be $(w_{1-4}, s_{1-4}$ and $l_{1-4})$ and $(w_{2-3}, s_{2-3},$ and $l_{2-3})$. Once again, in order to highlight the role of these geometrical parameters.

In the first step, we have plotted in Fig.5, the variation of the electrical response versus the coupled line length, as can be seen, the frequency response of microstrip coupled lines is affected by the different values of the strip length.

Fig.6, and Fig.7, demonstrates that the coupled microstrip filter is also sensitive to the increment and decrease w and s respectively. Taking into account the behavior of

the results, we update the dimensions of the compact microstrip BPF with the new values obtained from the optimization process, Fig.8.

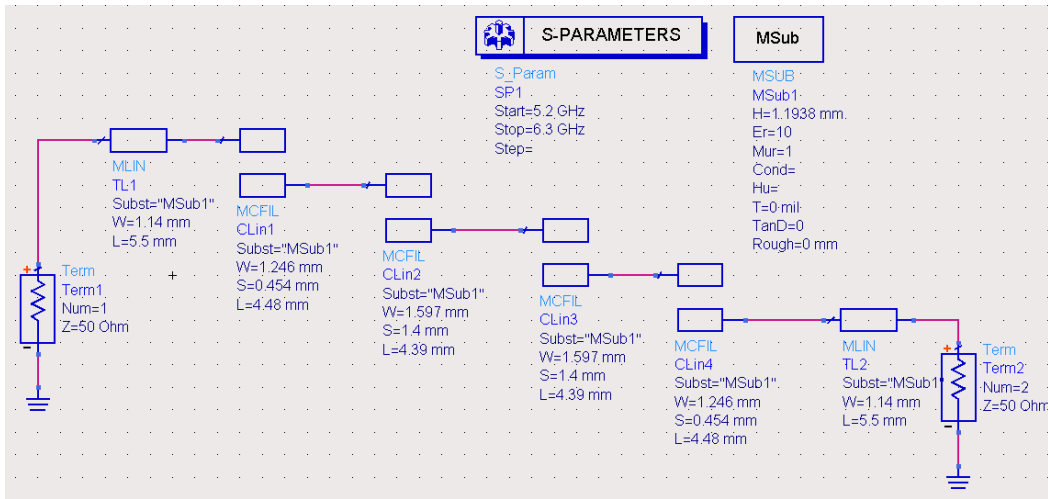

Figure 4: Schematic circuit of parallel-coupled microstrip BPF with Agilent ADS simulator

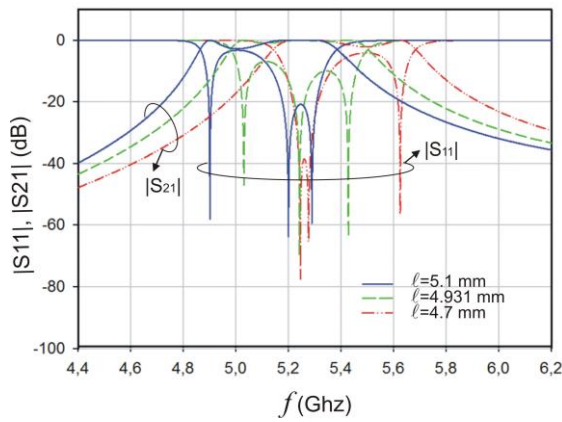

Figure 5: Electrical responses of the BPF for the several coupled lines length

1.4 mm (section 2 and 3), and $l = 5.5$ mm, $w = 1.14$ mm for the 50Ω line.

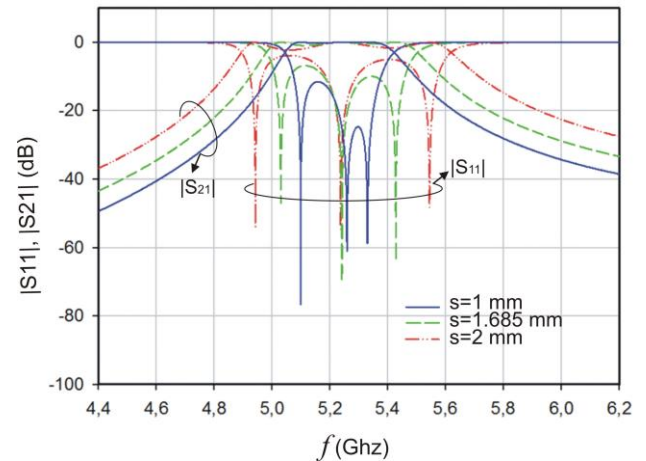

Figure 7: Effect of the coupled lines gap of the BPF

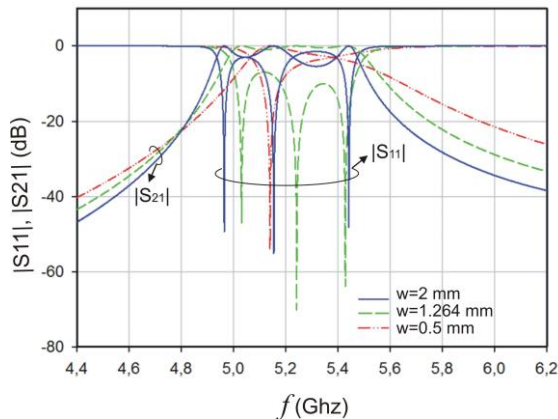

Figure 6: Electrical responses of the BPF for the several coupled lines width

The final refined geometrical parameters are: $l = 4.48$ mm, $w = 1.246$ mm and $s = 0.454$ mm (section 1 and 4), and $l = 4.39$ mm, $w = 1.597$ mm and $s =$

In figure 9, we plot the scattering parameters of the designed BPF with the final optimized geometrical parameters. It appears clearly that the centre frequency of the filter has been adjusted to 5.78 GHz and the bandwidth of 10% mentioned above is also obtained.

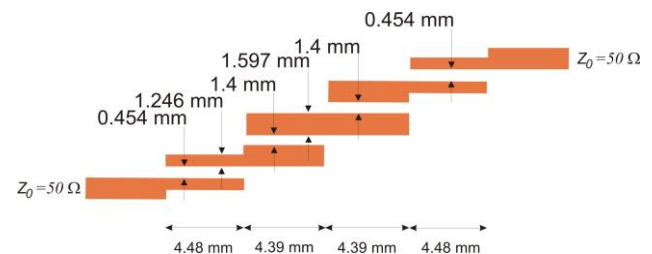

Figure 8: Refined geometrical parameters of the parallel-coupled BPF designed filter Layout

The corresponding insert loss is less than 1 dB and the reflect ratio in band-pass is -19.316 dB with an -56.889 dB attenuation in the alias frequency, which indicate that the request performance is well satisfied.

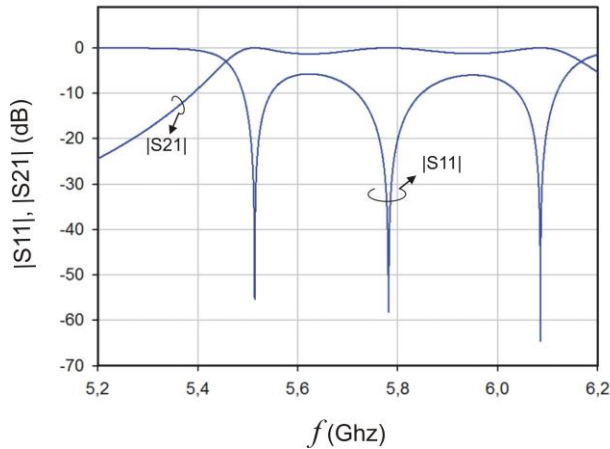

Figure 9: Optimized numerical simulations obtained from EM simulation Agilent ADS

2.3 CST-MW Studio Simulation

BP Chebyshev Filter of $\Delta = 10\%$ and Ripple 0.1 dB Substrate With $\epsilon_r = 10$ and $h = 1.1938$ mm

To validate the optimized results obtained with the Agilent ADS in the previous section, the parallel coupled microstrip BPF is simulated using the commercial simulator CST Microwave Studio.

The simulation performances which elaborate the specifications and simulations results are presented in Fig.10. As it can be shown, the optimized simulations of the return loss, S_{11} and the insertion loss, S_{21} for the designed filter are in good agreements for the both simulators.

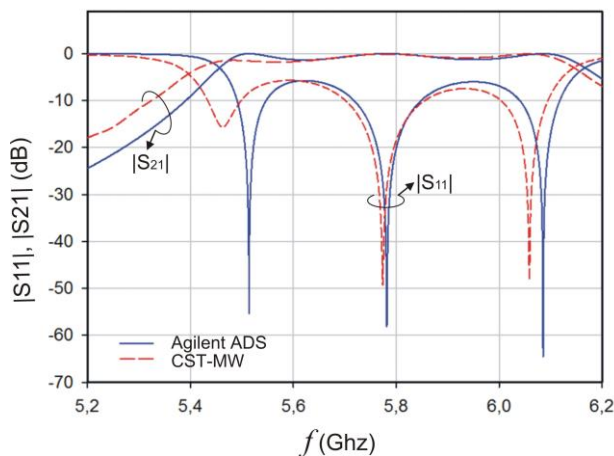

Figure 10: Numerical simulations obtained from EM simulation (Agilent ADS and CST-MW)

3. CONCLUSION

In this paper we have presented the procedure of designing parallel-coupled microstrip BPF for 5 GHz. Unlicensed WiMAX using The Transmission lines Theory Approach based on the coupling matrix concept. To validate the geometrical parameters design and build the different components of the filter, the design study is based on the use of the EM commercial simulators (Agilent ADS and CST-MW Studio). Finally, an optimized geometry of the filter has been then carried out and all results show good agreements. Note that the followed method can be applied to adjust the frequency and the bandwidth for any band-pass filter technology

ACKNOWLEDGEMET

The authors of this paper would like to thank Prof. M. Drissi, INSA of Rennes, France for helping us to carry out the CST simulations.

REFERENCES

- [1] Hong, J. S. and M. J. Lancaster, "Couplings of microstrip square open-loop resonators for cross-coupled planar microwave filters", IEEE Transactions on Microwave Theory and Techniques, Vol. 44, No. 12, p. 2099-2109, Dec. 1996.
- [2] G. Matthaei, L. Young, and E. M. T. Jones, "Microwave Filters, Impedance-Matching Networks, and Coupling Structures". Boston, MA: Artech House 1980, pp.583-650.
- [3] Institute of Electrical and Electronics Engineers, Inc., IEEE Wireless LAN Edition – "A Compilation based on IEEE Std 802.11TM-1999 (R2003) and its Amendments". New York, USA, 2003.
- [4] Mohamadou Baba, "Efficient Design, Integration and Optimization of Highly Miniaturized Filters for RF Wireless Applications", Department of System Design and Integration Fraunhofer Institute, Dissertation TU Berlin, 2008.
- [5] M. Brandolini et al., "Toward multistandard mobile terminals-fully integrated receivers requirements and architectures", IEEE Transactions on Microwave Theory and Techniques, vol. 53, no. 3, pp. 1026-1038, Mar. 2005.
- [6] IEEE Std 802.16-2004: Part 16: IEEE Standard for Local and metropolitan area networks: Air Interface for Fixed Broadband Wireless Access Systems, 2004.
- [7] IEEE Std 802.16e-2005: Part 16: IEEE Standard for Local and metropolitan area networks: Air Interface for Fixed Broadband Wireless Access Systems, 2005.

- [8] W. Chen, the Circuits and Filters Handbook, CRC Press LLC, 2003.
- [9] D. M. Pozar, Microwave Engineering, Fourth Edition, Wiley and Sons, 2012.
- [10] H. Karimi zarajabad and S. Nikmehr, "A Novel Fractal Geometry for Harmonic Suppression in Parallel Coupled- Line Microstrip BandPass Filter", International Conference on Microwave and Millimeter Wave Technology, ICMMT, pp. 1251-1254, 2008.
- [11] Miguel Bacaicoa, David Benito, Maria J. Garde, Mario Sorolla and Marco Guglielmi, "New Microstrip Wiggly-Line Filters with Spurious Pass-band Suppression", IEEE Transactions on Microwave Theory and Techniques, vol. 49, no. 9, pp. 1593-1598, September 2001.
- [12] J. S. Hong, M. J. Lancaster, "Microstrip Filter for RF/Microwave Applications", A Wiley Interscience Publication, Canada, 2001.
- [13] Bahareh Rezaei, Mohammad Pooyan and Towhid Zargar Ershadi, "Using Microstrip Elements in Dual-band Bandpass Filter with Parallel Coupled-Lines and Space Mapping Technique", The Computing Science and Technology International Journal, vol. 2, no. 3, pp. 39-43, September 2012.
- [14] Salima Seghier, Nadia Benabdallah, Nasreddine Benahmed Fethi Tarik Bendimerad and Kamila Aliane, "Design and Optimization of Parallel Coupled Microstrip Bandpass Filter for FM Wireless Applications", The Computing Science and Technology International Journal, vol. 2, no. 1, pp. 39-43, March 2012.
- [15] Rashid Ahmad Bhatti, Jahangir Khan Kayani, "Design and analysis of parallel coupled microstrip band pass filter", 2nd International Bhurban Conference on Applied Sciences and Technology, Bhurban, Pakistan. June 16-21, pp. 168-176, 2003.
- [16] Maria del Castillo Velzquez-Ahumada, Jesus Martel, and Francisco Medina, "Parallel coupled microstrip filters with floating ground-plane conductor for spurious-band suppression", IEEE transactions on Microwave Theory and Techniques, vol. 53, no. 5, pp. 1823-1828 May 2005.
- [17] Maria del Castillo Velzquez-Ahumada, Jesus Martel, and Francisco Medina, "Design of Compact Low-Pass Elliptic Filters Using Double-Sided MIC Technology", IEEE Transactions on Microwave Theory and Techniques, vol. 50, no. 1, pp. 121-127, January 2007.
- [18] S. Tavakoli, M. Zeindini, S. Mohanna, "Modelling and Design of a Microstrip Band-pass Filter Using Space Mapping Techniques", Journal of Telecommunications, vol. 2, issue 1, pp. 29-34, April 2010.
- [19] Jolly Rajendran, Rakesh Peter, and K. P. Soman, "Design and Optimization of Band Pass Filter for Software Defined Radio Telescope", International Journal of Information and Electronics Engineering, vol. 2, no. 4, pp. 694-651, July 2012.
- [20] Sina Akhtarzard, Thomas R. Rowbotham, and Petter B. Johns, "The Design of Coupled Microstrip Lines", IEEE Transactions on Microwave Theory and Techniques, vol. MTT-23, no. 6, pp. 486-492, June 1975.