

Universal Numeric Quantifiers in Japanese¹

Masao Ochi

ochi@lang.osaka-u.ac.jp

Osaka University

DOI to be assigned

Abstract: This paper examines a subtype of floating quantifiers, in which a universal quantifier along with a numeral appear at a distance from their nominal associate. According to Cirillo (2010), this floating universal numeric quantifier (UNQ) construction is found in some (but not all) Romance and Germanic languages. While Cirillo provides strong evidence for a stranding analysis (cf. Sportiche, 1988; Bošković, 2004) of the floating UNQ rather than an adverbial approach (cf. Bobaljik, 2004; Nakanishi, 2006), his most crucial data could be accommodated under a particular version of the adverbial view, advocated by Doetjes (1997) and Fitzpatrick (2006), which postulates *pro* inside a base-generated adjunct nominal. Building on Kawashima's (1994; 1998) observations about Japanese, this paper argues that (i) Japanese also has the adnominal/floating UNQ and (ii) the stranding approach is superior to the *pro*-based adverbial analysis noted above in handling the floating UNQ. To show this, I will examine in some depth the syntax of adnominal quantification in Japanese (and Chinese) with a special focus on the ways in which numeral classifiers interact with other adnominal elements. Several theoretical consequences of the analysis will be explored, including the nature of quantifier stranding and syntactic locality.

Keywords: *floating quantifier, Japanese, noun phrase, numeral classifier.*

¹ It is a great honour for me to be able to contribute this paper for the special issue in honour of Andrew Radford. Andrew taught me the foundations of syntactic theory when I was a new graduate student at Essex 20 years ago. He helped me work on the structure of the noun phrase in Japanese for my MA thesis, and now I am revisiting the same issue in this paper.

The material in this paper grew out of recent collaborative work with Jim Huang (Huang and Ochi, 2011; 2012). I would like to thank Jim for discussing with me various issues in the syntax and semantics of noun phrases in East Asian languages. My sincere thanks also go to two anonymous reviewers for useful comments, and to the editors of *Iberia* for excellent editorial assistance. This research is financially supported by the Grant-in-Aid for Scientific Research (C) (No. 22520398), the Ministry of Education, Culture, Sports, Science, and Technology of Japan.



Resumen: Este artículo examina un subtipo de los cuantificadores flotantes, en el que un cuantificador universal junto con un numeral aparece a una cierta distancia de su asociado nominal. De acuerdo con Cirillo (2010), esta construcción de cuantificador numérico universal flotante (CNU) es encontrada en algunas (pero no todas) lenguas románicas y germánicas. Mientras Cirillo facilita evidencia contundente para un análisis de encallamiento (cf. Sportiche, 1988; Bošković, 2004) del CNU flotante en lugar de una aproximación adverbial (cf. Bobaljik, 2004; Nakanishi, 2006), su dato más crucial podría ser acomodado bajo una versión particular de la visión adverbial, defendida por Doetjes (1997) y Fitzpatrick (2006), quienes postulan que *pro* se encuentra dentro de un adjunto nominal generado en su posición superficial. Basándome en las observaciones del japonés llevadas a cabo por Kawashima (1994; 1998), este artículo arguye que (i) el japonés también tiene el CNU adnominal/flotante y (ii) la aproximación de encallamiento es superior al análisis adverbial basado-*pro* observado anteriormente en el manejo del CNU flotante. Con el fin de demostrar esto, examinaré con cierta profundidad la sintaxis de la cuantificación adnominal del japonés (y chino) prestando especial atención a las formas en las que los clasificadores nominales interactúan con otros elementos adnominales. Varias consecuencias teóricas del análisis serán analizadas, incluida la naturaleza del encallamiento del cuantificador y la localidad sintáctica.

Palabras clave: *Cuantificador flotante, japonés, sintagma nominal, clasificador numeral.*

Resumo: Este artigo analisa um subtipo de quantificadores flutuantes, em que um quantificador universal e um numeral surgem distantes do nome ao qual estão associados. De acordo com Cirillo (2010), estes 'quantificadores numerais universais' (UNQ) flutuantes surgem em algumas (mas não todas) línguas românicas e germânicas. Apesar de Cirillo apresentar fortes evidências para uma análise de encaixe (e.g., Sportiche 1988, Bošković 2004) para os UNQ flutuantes em vez de uma análise adverbial (Bobaljik 2004, Nakanishi 2006), os dados apresentados devem ser analisados a partir de uma versão da análise adverbial, postulada por Doetjes (1997) e Fitzpatrick (2006), segundo a qual *pro* está inserido num adjunto adnominal gerado na base. Partindo das observações de Kawashima (1994, 1998) para o Japonês, este artigo defende que: (i) o japonês também tem UNQ adnominais/flutuantes e (ii) a análise de encaimento é mais adequada do que a análise adverbial, já apresentada, para explicar os UNQ flutuantes. Neste sentido, examinarei a sintaxe dos quantificadores adnominais no japonês (e no chinês) com especial enfoque na forma como os classificadores numerais interagem com outros elementos de natureza adnominal. Diversas consequências teóricas da análise serão exploradas, incluindo a natureza do quantificador encaido e localidade sintática.

Palavras-chave: *quantificador flutuante, japonês, sintagma nominal, classificador numeral.*





1. Introduction

The main focus of this paper is a subtype of the floating quantifier (FQ) construction. (1b) shows a typical example of this construction.

- (1) a. **All** the students have left the party.
 b. The students have **all** left the party.

There has been debate in the literature about whether pairs like (1) are related in terms of transformation. One prominent view, typically ascribed to Sportiche's (1988) seminal work, is known as the 'stranding' approach (see Bošković, 2004 for a recent analysis along these lines). According to this view, a 'floating' quantifier and its nominal associate (*the students* in the above examples) form a constituent at some (early) point in the derivation and are subsequently separated in the course of the derivation. Another prominent view takes the FQ to be a base-generated adverb of some kind (see Bobaljik, 2004 among others). Languages like Japanese are known to allow quantifiers other than universal quantifiers, including numeral classifiers, to be separated from their nominal associates. Not surprisingly, such paradigms in Japanese have also been the focus of intense debate, with some scholars adhering to (variants of) the stranding approach (following Miyagawa's (1989) early work) and others arguing vehemently in favour of the adverbial approach (see for example Nakanishi's (2007) recent discussion along these lines).

Against this background, this paper deals with a subtype of floating quantifiers that Cirillo (2010) calls the floating universal numeric quantifier (henceforth UNQ), which, according to Cirillo, is found in some Germanic and Romance languages. The Dutch example in (2a) exemplifies the UNQ construction (all Dutch examples in this paper are taken from Cirillo, 2010). Just like in (2a), *alle drie* 'all three' in (2b) modifies the subject *de studenten* 'the students', even though *alle drie* appears separately from the subject noun. Following Cirillo (2010), I will refer to examples like (2b) as the floating/stranded UNQ construction.

- (2) a. **Alle drie** de studenten hebben het boek gelezen.
 all three the students have the book read
 b. De studenten hebben **alle drie** het boek gelezen.
 the students have all three the book read



One important feature of Cirillo's (2010) analysis is that the floating UNQ clearly resists an adverbial analysis. When a universal quantifier in Dutch is stranded on its own, it may, and often does, take the adverbial form (*-maal* being an adverbial suffix), as shown in (3b). However, it cannot appear in the adverbial form in the UNQ construction, as shown in (4b):

- (3) a. **Al** de studenten hebben het boek gelezen.
all the students have the book read
b. De studenten hebben **allen/allemaal** het boek gelezen.
the students have all/all (adv.) the book read
- (4) a. **Alle drie** de studenten hebben het boek gelezen.
all three the students have the book read
b. *De studenten hebben **alle** /***allemaal** drie het boek gelezen.
the students have all/ all (adv.) three the book read

While this fact clearly favors the splitting/stranding view of the floating UNQ, it might still be accommodated under a version of the adverbial view, advocated by Doetjes (1997) and Fitzpatrick (2006), which postulates *pro* inside an adjunct, as shown in (5):

- (5) The students have [all *pro*] left the party.

Proponents of this line of analysis might be able to argue that the adverbial form is barred from the floating UNQ because it is a nominal adjunct:

- (6) De studenteni hebben [_{VP} [**alle**/***allemaal** **drie** *pro*i] [_{VP} het boek gelezen]]

In this paper, I will analyze Japanese examples like (7) below, which were originally discussed by Kawashima (1994, 1998):

- (7) taro-wa gyooza-o (sono toki) **hyaku-ko subete** tabe-ta.
Taro-TOP dumpling-ACC that time 100-CL **∇** eat-PAST
'Taro ate all of the 100 dumplings (at that time).'

Here, a case particle appears on the noun *gyooza* 'dumpling,' which is followed by a numeral classifier (NC) and a universal quantifier. Although Kawashima takes sequences such as *gyooza-o hyaku-ko subete* 'dumpling-acc 100-CL **∇**' to be a nominal constituent, I assume the contrary, mainly because adverbs like *sono toki* 'that time' can be freely inserted inside such sequences, as shown in this example.² I assume that Case-particles such as *-ga* and *-o* mark the right boundary of the nominal constituent, which means that *gyooza-o* is a surface

² Kawashima's claim is mainly based on the coordination of the sequence *N-Case+NC+∇* and another nominal, but such data can be reinterpreted as the coordination of larger constituents, such as VPs (see Koizumi, 2000).





constituent on its own in the above example. Given the similarity between the UNQ in Germanic/Romance (as explained by Cirillo) and examples like (7) in Japanese, I will explore the hypothesis that the latter is also an instance of the floating/stranded UNQ.

This paper has two major goals. First, it aims to provide evidence from Japanese that even the Doetjes/Fitzpatrick type of adverbial analysis is inadequate for handling the floating UNQ. Second, it aims to identify the underlying (i.e., pre-stranding) structure of the floating UNQ in Japanese. Due to the intricate nature of the discussions leading to the identification of the pre-stranding source of the floating UNQ in Japanese, I will focus on this second goal first. In order to do this, I will base my analysis on previous studies on the syntax of noun phrases in Japanese, especially Huang and Ochi (2011, 2012). The crucial evidence for the stranding approach to the floating UNQ will be presented towards the end of the paper.

The paper is organized as follows: section 2 introduces several properties of the floating UNQ construction in Japanese. Section 3 consists of four subsections, and is devoted to the investigation of the adnominal (i.e., pre-stranding) UNQ. I will introduce and rely on some ideas from previous studies, especially Saito et al (2008), Watanabe (2006) and Huang and Ochi (2011, 2012). Having identified the most likely source of the floating UNQ in section 4, I will explore some additional possible sources of the floating UNQ in section 5. A crucial piece of evidence against the Doetjes/Fitzpatrick type analysis of the floating UNQ is also discussed. Section 5 summarizes and concludes the discussion.

2. Some properties of the floating UNQ in Japanese

I would now like to highlight three properties of the floating UNQ in Japanese, which will be useful in the following sections when probing into the nominal structure of Japanese to find the adnominal (i.e., pre-stranding) source of examples like (7). First, the linear order of a numeral and a universal quantifier cannot be reversed, as pointed out by Kawashima. Observe the contrast in acceptability between (7) and (8) below:





- (8) *Taro-wa gyooza-o (sono toki) **subete hyaku-ko** tabe-ta.
 Taro-TOP dumpling-ACC that time \forall 100-CL eat-PAST
 'Taro ate all of the 100 dumplings (at that time).'

Second, although Japanese allows quantifiers other than universal quantifiers, such as *hotondo* 'most' and *takusan* 'many', to float (see (9a)), the floating/stranded UNQ is only possible with a universal quantifier, as shown in (9b):

- (9) a. Taro-wa tsukue-ni aru gyooza-o **takusan/hotondo** tabe-ta.
 Taro-TOP table-DAT be dumpling-ACC many/most eat-PAST
 'Taro ate many/most of the dumplings on the table.'
- b. Taro-wa tsukue-ni aru gyooza-o **hyaku-ko**
 Taro-TOP table-DAT be dumpling-ACC 100-CL
 takusan**/hotondo**/**subete** tabe-ta.
 many/most/ \forall eat-PAST
 '(intended) Taro ate many/most/all of the 100 dumplings on the table'

The floating/stranded UNQ in Japanese is, in a sense, 'well behaved', in that a number of languages only allow universal quantifiers to float (see Fitzpatrick 2006), although this property in and of itself demands an explanation.

Third, unlike the ordinary floating NC, the floating UNQ is incompatible with a partitive interpretation. This is demonstrated by the examples in (10). As repeatedly pointed out in the previous literature (see Inoue (1978) and Watanabe (2008) among others), a floating NC typically yields a partitive reading, especially when its associate is a definite nominal (e.g., when the latter is modified by a relative clause). In (10a), for example, *gyooza* 'dumpling' is modified by a prenominal NC, *hyaku-ko* '100-CL', as well as a floating NC, *sanjyu-ko* '30-CL'. The former NC expresses the cardinality of the set of dumplings on the table, and the latter NC (in conjunction with the denotation of the head noun) picks out its subset. (10b) shows that a universal quantifier can occur in the same environment as floating NCs. However, (10c), which places the floating UNQ in the same environment, is deviant.³

- (10) a. Taro-wa tsukue-ni aru **hyaku-ko-no** gyooza-o **sanjyu-ko** tabe-ta.
 Taro-TOP table-DAT be 100-CL-GEN dumpling-ACC 30-CL eat-PAST
 'Taro ate 30 of the 100 dumplings on the table.'
- b. Taro-wa tsukue-ni aru **hyaku-ko-no** gyooza-o **subete** tabe-ta.
 Taro-TOP table-DAT be 100-CL-GEN dumpling-ACC \forall eat-PAST
 'Taro ate all of the 100 dumplings on the table.'

³ The example is of course fine without the prenominal NC *hyaku-ko* '100-CL'.





- c. *taro-wa tsukue-ni aru **hyaku-ko-no** gyooza-o **sanju-ko** **subete**
 Taro-TOP table-DAT be 100-CL-GEN dumpling-ACC 30-CL \forall
 tabe-ta
 eat-PAST
 'Taro ate all of the 30 dumplings out of the 100 dumplings on the table.'

3. Adnominal NCs/universal quantifiers in Japanese

With the three properties identified in section 2 at hand, attempts can be made to see if the 'pre-stranding' source of examples like (7) can be identified, assuming that the floating UNQ indeed involves stranding (a crucial piece of evidence for this position will be presented towards the end of the paper).

3.1 Data

First, it is necessary to check the basic distribution of adnominal classifiers/quantifiers in Japanese. As shown in (11) and (12), NCs and the universal quantifier *subete* can appear in three environments: (a) prenominal, (b) postnominally, and (c) floating/stranded.

- (11) a. Taro-wa **jyu-ko-no** (*kinoo) gyooza-o (kinoo) tabe-ta.
 Taro-TOP 10-CL-GEN yesterday dumpling-ACC yesterday eat-PAST
 'Taro ate 10 dumplings (yesterday).'
- b. Taro-wa gyooza (*kinoo) **jyu-ko-o** (kinoo) tabe-ta.
 Taro-TOP dumpling yesterday 10-CL-ACC yesterday eat-PAST
 'Taro ate 10 dumplings (yesterday).'
- c. Taro-wa gyooza-o (kinoo) **jyu-ko** tabe-ta.
 Taro-TOP dumpling-ACC yesterday 10-CL eat-PAST
 'Taro ate 10 dumplings.'
- (12) a. Taro-wa **subete-no** (*kinoo) gyooza-o (kinoo) tabe-ta.
 Taro-TOP \forall -GEN yesterday dumpling-ACC yesterday eat-PAST
 'Taro ate all of the dumplings (yesterday).'
- c. Taro-wa gyooza (*kinoo) **subete-o** (kinoo) tabe-ta.
 Taro-TOP dumpling yesterday \forall -ACC yesterday eat-PAST
 'Taro ate all of the dumplings (yesterday).'
- b. Taro-wa gyooza-o (kinoo) **subete** tabe-ta.
 Taro-TOP dumpling-ACC yesterday \forall eat-PAST
 'Taro ate all of the dumplings (yesterday).'

I assume that a prenominal quantifier and a postnominal quantifier are part of the noun phrase: adverbs like *kinoo* 'yesterday' cannot separate them from the head noun.

Given that *subete* ' \forall ' and NCs can, in principle, appear prenominal or postnominally, there are several possibilities to consider when they combine:



both occurring prenominally (13), both occurring postnominally (15), and one of them occurring prenominally and the other postnominally (14) (see Huang and Ochi, 2011, 2012):

- (13) a. *Taro-wa **subete-no hyaku-ko-no** gyooza-o tabe-ta.
Taro-TOP **∀**-GEN 100-CL-GEN dumpling-ACC eat-PAST
'Taro ate all (of the) 100 dumplings'
- b. *Taro-wa **hyaku-ko-no subete-no** gyooza-o tabe-ta.
Taro-TOP 100-CL-GEN **∀**-GEN dumpling-ACC eat-PAST
- (14) a. *Taro-wa **subete-no** gyooza **hyaku-ko-o** tabe-ta.
Taro-TOP **∀**-GEN dumpling 100-CL-ACC eat-PAST
'Taro ate all (of the) 100 dumplings'
- b. Taro-wa **hyaku-ko-no** gyooza **subete-o** tabe-ta.
Taro-TOP 100-CL-GEN dumpling **∀**-ACC eat-PAS
- (15) a. *Taro-wa gyooza **subete hyaku-ko-o** tabe-ta.
Taro-TOP dumpling **∀** 100-CL-ACC eat-PAST
'Taro ate all (of the) 100 dumplings.'
- b. Taro-wa gyooza **hyaku-ko subete-o** tabe-ta.
Taro-TOP dumpling 100-CL **∀**-ACC eat-PAST

Of the six possibilities shown above, only two yield good results: (14b) and (15b). In particular, *subete* '∀' must appear postnominally in the presence of an NC modifying the same nominal. The NC, on the other hand, may appear prenominally (14b) or postnominally (15b). I will therefore proceed with the assumption that the pre-stranding source of the floating UNQ is the pattern shown in (14b), the one in (15b), or potentially both (see sections 4 and 5 for details). In the next subsection, I will lay out some specific assumptions and proposals to deal with the (un)grammaticality of (13)-(15).

3.2 Theoretical assumptions (based on Huang and Ochi, 2011, 2012)

Regarding the syntax of adnominal classifiers, I will essentially adopt Huang and Ochi's (2011, 2012) proposal, with an eye to extending it to the UNQ construction. The gist of their analysis is that a prenominal CL and a postnominal CL in Japanese should not be given a unified analysis, contrary to Watanabe's (2006) proposal. To be more specific, following Saito et al (2008) and Miyamoto (2009), Huang and Ochi assume that a prenominal NC occurs as an adjunct to NP, as shown in (16).⁴ Following Saito et al (2008), I also assume that

⁴ According to Miyamoto (2009), the prenominal NC has a fairly large internal structure (i.e., a relative clause structure). I will not go into details here.





any prenominal modifier (e.g., adnominal adjectives, relative clauses, etc.) has the same adjunct status at the NP-level.

- (16) a. san-ko-no gyooza
3-CL-GEN dumpling
'three dumplings'

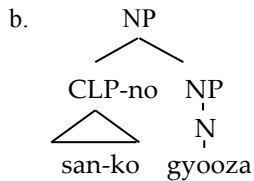

As for postnominal NCs, Huang and Ochi adopt Watanabe's (2006) analysis, shown in (17). According to Watanabe, the postnominal NC is a (functional) head that selects NP as its complement (see also Murasugi, 1991 and Kawashima, 1998, among many others), and a number phrase is located in the specifier of the classifier phrase (henceforth CLP). Watanabe also proposes that NP moves to the edge of the (extended) nominal domain, yielding the correct surface word order.

- (17) a. gyooza san-ko
dumpling three-CL
'three dumplings'

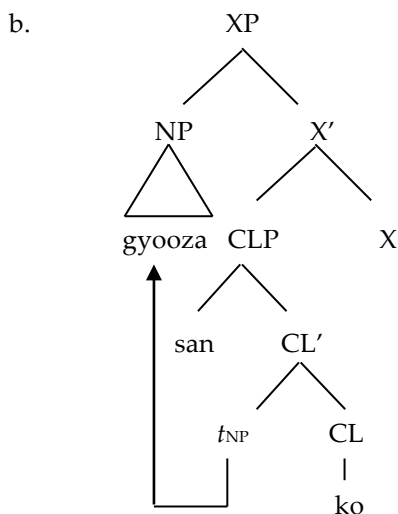

To the extent that this line of analysis for a numeral classifier is tenable, one might expect other quantifiers to fall under the same, non-uniform analysis. Accordingly, I will explore the idea that the prenominal *subete* '∀' is an adjunct to NP whereas the postnominal *subete* is a head taking NP as its complement.⁵

⁵ If the postnominal *subete* is in the specifier of an abstract head ('X' in (i) below) which selects NP as its complement, one must assume that NP moves to the edge of the





(18) a. subete-no gyooza
 ∀-GEN dumpling
 'all dumplings'

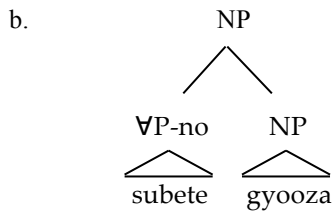

(19) a. gyooza subete
 dumpling ∀
 'all dumplings'

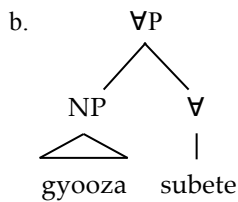

Two points are worth highlighting here. First, this line of analysis entails that a prenominal quantifier is structurally lower than a postnominal quantifier: the former is part of an NP whereas the latter selects an NP as its complement. I will review Huang and Ochi's argument to this effect shortly. Second, NP-movement is assumed to be obligatory in the postnominal NC construction in Japanese: this point will be important as I later try to relate this particular aspect of the postnominal NC to the floating/stranded NC. Although the right word order is obtained as a result of this movement, one might wonder if there is any support for postulating such NP-movement. Watanabe (2006) offers no such evidence, while Huang and Ochi manage to present some indirect arguments for the alleged NP-movement based on specificity. In the next subsection, I will present evidence which could potentially provide support for such nominal-internal NP-movement, based on a comparison of Chinese and Japanese with respect to the way in which the classifier interacts with a plural/collective element.

nominal, in a manner analogous to the situation in the postnominal NC construction (see Watanabe, 2006). Since nothing hinges on the choice between these two alternatives, I will assume the simpler structure shown in (19).

(i) [_{YP} NP [_{XP} subete [_{t_{NP}} X] Y]]





3.3. Classifiers and collective/plural elements in Chinese and Japanese

This subsection begins with an assumption about the syntax of classifiers in Chinese. Following previous works on this topic such as Tang (1990), Cheng and Sybesma (1999) and Li (1998, 1999), Huang and Ochi assume that the NC construction in Chinese has a structure like (21), in which the classifier is a head selecting NP as its complement, accommodating a number phrase in its specifier.⁶

(20) san-ben (*-de) shu
 three-CL book
 'three books'

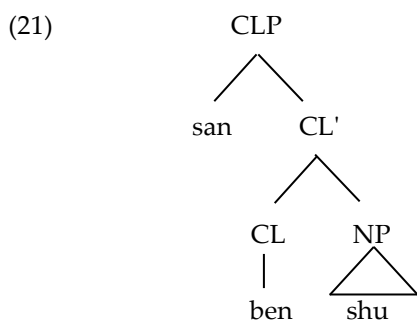

Now compare (17) and (21). The postnominal NC in Japanese and the NC structure in Chinese are assumed to share the same structure: both involve the classifier head that takes NP as its complement, and a number phrase is sitting in its specifier. One crucial difference, however, is that the postnominal NC in Japanese involves movement of NP whereas the Chinese classifier (CL) construction does not. This difference will be crucial in the following discussion.

I will now examine some data containing plural/collective suffixes in the two languages: *-men* in Chinese and *-tachi* (and *-ra*) in Japanese. As noted in previous literature (see in particular Kurafuji, 2004), these suffixes have a number of inherent semantic properties in common. First, these suffixes must attach to a noun denoting a human (e.g., **shu-men*/**hon-tachi* 'books'). Second, they yield two different readings, depending on the type of noun to which they

⁶ Huang and Ochi propose that (i) UG makes available two syntactic strategies for the NC: as a head and as an XP modifier, and (ii) Chinese resorts to the head option while Japanese employs both. Why the two languages pattern the way they do is an interesting question for which I have no concrete proposal to offer at this point. See, however, Giusti (1991) and Shlonsky (2004) for proposals regarding a dual syntactic status of cardinal expressions in languages other than Chinese and Japanese. Thanks to an anonymous reviewer for urging me to clarify this important point.





are attached. When attached to common nouns, these suffixes typically yield a plural reading, as illustrated in (22). In this respect, *-men* and *-tachi* are similar to *-s* in English.

- (22) a. xuesheng-men
student-MEN
'the students'
- b. gakusei-tachi
student-TACHI
'(the) students'

When attached to proper names, these suffixes typically yield the so-called 'collective' reading (i.e., "X and others"), although, as Li (1999) notes, such examples also allow a plural reading (a group of people with the same name, e.g., Xiao Qiang). The same seems to be true of Japanese examples like (23b); although the salient reading for this example is the collective reading, the plural reading is also possible. This point is highlighted by the addition of a prenominal NC modifier, as shown in (24), because (24) crucially lacks the collective reading. I will discuss this in more detail shortly:

- (23) a. Xiao Qiang-men
Xiao Qiang-MEN
'Xiao Qiang and others' (collective)
'a group of people all named Xiao Qiang' (plural)
- b. hanako-tachi
taro-TACHI
'Hanako and others' (collective)
'a group of people all named Hanako' (plural)
- (24) san-nin-no hanako-tachi
three-CL-GEN hanako-TACHI
'three people all named Hanako' (plural)
'#Hanako and two others (in the group)' (collective)

Third, Li (1999) points out that the attachment of *-men* forces the resulting nominal expression to be definite, as shown in (25b).

- (25) a. wo qu zhao haizi.
I go find child
'I will go find some/the child(ren).'
- b. wo qu zhao haizi-men.
I go find child-MEN
'I will go find the children.'





According to Kurafuji (2004), the same property is observed for *-tachi* in Japanese.⁷ For example, while (26a) is fully felicitous in a situation in which finding any child(ren) will fulfill the speaker's desire, (26b) sounds strange in a situation in which the speaker has no particular group of children in mind:

- (26) a. Boku-wa kodomo-o sagashiteiru.
 I-TOP child-ACC look for
 'I'm looking for some/the child(ren).'
- b. Boku-wa kodomo-tachi-o sagashiteiru.
 I-TOP child-TACHI-ACC look for
 'I'm looking for some specific group of children.'

There is one striking difference between *-men* and *-tachi*, however. According to Iljic (1994) and Li (1999), *-men* and the classifier cannot co-occur when the former is attached to a common noun.⁸ No such restriction applies in the corresponding case in Japanese. As shown in (27b) and (27c), *-tachi* can occur with a prenominal/postnominal NC.

- (27) a. wo qing san-ge xuesheng(*-men) chifan.
 I invite three-CL student-MEN eat
 'I invited (the) three students for a meal.'
- b. boku-wa san-nin-no gakusei-tachi-o maneita.
 I-TOP three-CL-GEN student-TACHI-ACC invited
 'I invited (the) three students for a meal.'
- c. boku-wa gakusei-tachi san-nin-o maneita.
 I-TOP student-TACHI three-CL-ACC invited
 'I invited (the) three students for a meal.'

As pointed out by Li (1999), however, there is no inherent incompatibility between *-men* and a classifier. They can co-occur when *-men* is attached to a proper noun (or a pronoun) occurring in the left edge of a nominal phrase, as

⁷ But see Nakanishi and Tomioka (2004) for a different view. While they offer several arguments to the effect that *-tachi* is not inherently definite, what is crucial here is that the suffixes in the two languages share some property P (be it definiteness or something else) and that P is tied to the syntactic dependency between N-*men/-tachi* and a higher functional head, to be discussed shortly. It is therefore necessary to examine whether or not the points and observations made by Nakanishi and Tomioka for *-tachi* also hold for *-men*, a task that I have to leave for another occasion.

⁸ Previous analyses of this phenomenon include Borer's (2005) morphosyntactic account and Bale & Khanjian's (2008) semantic account. The former works well for Chinese but fails to extend to Japanese. The latter discusses some interesting facts about Armenian compared with English; but it also fails to capture the facts about Japanese.



shown in (28a).⁹ Li (1999) notes that this case lacks the plural reading (unlike (23a)). The parallel situation is found in Japanese, as shown in (28b, c). The expression *hanako-tachi* is followed by *san-nin-no jyosei* 'three-cl-gen lady' in (28b), and by *jyosei san-nin* 'lady three-CL' in (28c). In both cases, only the collective reading obtains, in contrast with the situation in (24).

- (28) a. wo qing Xiao Qiang-men san-ge (ren) chifan.
 I invite Xiao Qiang-MEN three-CL person eat
 'I invited Xiao Qiang and two others (in the group) for a meal.' (collective)
 # 'I invited the three people all named Xiao Qiang.' (plural)
- b. boku-wa hanako-tachi san-nin-no jyosei-o maneita.
 I-TOP Hanako-TACHI three-CL-GEN lady-ACC invited
 'I invited Hanako and two other ladies (in the group).' (collective)
 # 'I invited the three ladies all named Hanako.' (plural)
- c. boku-wa hanako-tachi jyosei san-nin-o maneita.
 I-TOP Hanako-TACHI lady three-CL-ACC invited
 'I invited Hanako and two other ladies (in the group).' (collective)
 # 'I invited the three ladies all named Hanako.' (plural)

A brief review of the main aspects of Li's (1999) analysis may now be informative.¹⁰ First, she proposes that different types of noun may be base-generated in distinct positions within the nominal domain: a common noun is base-generated under N, a pronoun is base-generated in (the specifier of) D, and a proper name may be base-generated in either position. The following table summarizes this point.

(29)

	under N	in the domain of D
Common noun	OK	*
Pronoun	*	OK
Proper name	OK	OK

Li claims that the interpretation of a proper name is affected by the choice of its base position: when base-generated in SpecDP, it is interpreted as a referential expression; when base-generated in N, it is interpreted like a common noun, denoting an entity/entities with the characteristics typically ascribed to that proper name. As Li notes, a proper name in English could be interpreted like a common noun in some cases: it may be pluralized (e.g., *I met two Bills at the*

⁹ Examples like (28) do not involve an appositive structure. See Huang et al (2009: chapter 8) for discussion.

¹⁰ Li's analysis in fact deals with a wider array of data than reported here. See Li (1999) for a fuller discussion.





party.) or it may appear with an article (e.g., *I like the Bill you like*, etc.). This point made by Li is important, since, as will shortly be seen, it allows the two readings associated with *-men* (and *-tachi*) to be captured in purely structural terms.

Second, Li proposes that *-men* is a plural morpheme suffixed to an element in SpecDP. This point is responsible for the fact that [N-*men*] is interpreted as definite (see (25b)). Take pronouns, which, according to Li, are always base-generated in the domain of D. For example, *wo-men* ‘we’ is generated with *wo* ‘I’ base-generated in SpecDP, to which *-men* is attached. Note that only the collective reading obtains in this case: *wo-men* ‘we’ means ‘a group consisting of ‘I’ and others’, not a group consisting of multiple instances of ‘I’.¹¹ On the other hand, common nouns are always base-generated in N. According to Li, such nouns undergo head movement to D when acting as a host for *-men*, as shown in (30). Because *-men* is assumed to be a suffix to an element in (the domain of) D, the definite reading obtains in such cases.¹²

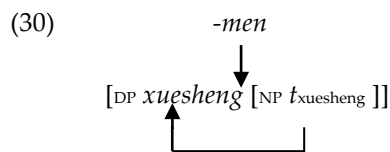

Now, recall that *-men* yields the plural reading when suffixed to a common noun (see (22)). I will therefore assume (following Li) that *-men* yields the collective reading when attached to an element originating in the domain of D (e.g., *wo-men* ‘we’), and the plural reading when attached to an element that originates in N (e.g., *xuesheng-men* ‘the students’).

The ambiguity of (23) is captured in purely structural terms under Li’s analysis. If a proper name is generated in SpecDP, the collective reading obtains with *-men* suffixed. When a proper name is generated in N, the attachment of *-men* (after the N-to-D movement) yields the plural reading (on a par with the situation in which *-men* is suffixed to a common noun).

¹¹ One cannot pluralize a referential expression under ordinary circumstances.

¹² To be more precise, Li proposes that *-men* is generated in the Num head, located between NP and DP. I will simplify her analysis here, as I will restate her analysis shortly in any event.

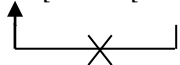

Third, Li further proposes that this N-to-D movement can be blocked by an intervening head, as a violation of the Head Movement Constraint (HMC). This, according to Li, is why *-men* and a classifier cannot co-occur (see (27a)).

- (31) [DP D [CLP CL [NP N]]]

Now, one point needs to be clarified in Li's (1999) analysis of Chinese. Although not explicitly stated, Li seems to assume that N-to-D movement takes place in overt syntax in Chinese. This is questionable, however. In Italian, certain adnominal adjectives (e.g., "thematic" adjectives) are necessarily preceded by the head noun, which has often been taken as evidence for (partial) N-raising (but see also Cinque, 2010 for a different analysis): observe the contrast in grammaticality in the following pair, taken from Cinque (1994):

- (32) a. *L'italiana invasione dell' Albania
the-Italian invasion of-the Albania
'the Italian invasion of Albania'
b. L'invasione italiana dell' Albania
the-invasion Italian of-the Albania
'the Italian invasion of Albania'

As shown in (33), however, adnominal adjectives always precede the head noun in Chinese, which would be unexpected if N-raising occurs in overt syntax.

- (33) a. wo zhaodao-le kaile-de haizi-men le.
I found-ASP happy-DE child-MEN
'I found the happy children.'
b. *wo zhaodao-le haizi-men kaile(-de) le.
I found-ASP child-MEN happy

I will therefore assume that N-raising in Chinese takes place in covert syntax. This point necessitates a slight modification of Li's analysis. In particular, I will restate Li's analysis in terms of covert feature checking, and extend it to Japanese:¹³

¹³ As a reviewer notes, postulation of a covert movement needs more justification. While I agree with this methodological point, I also think that the impressive degree of success that Li's analysis has achieved in capturing a rather intricate property of *-men* (in particular, its definiteness effect and the possible/impossible interpretations in various contexts in which *-men* appears) would amply justify recasting her analysis in terms of covert movement and, furthermore,





- (34) a. *-men* and *-tachi* are plural morphemes, which are suffixed to a nominal element when the latter enters the derivation.
- b. These suffixes bear some feature relevant for definiteness (but see also footnote 7), which needs to be checked against a higher functional head Y.¹⁴

The relevant functional head of (34b) may be D, but I will not commit myself as to the exact label of this functional head, simply referring to it as Y.¹⁵ Although involving some degree of departure from Li's original analysis, the statements in (34) retain Li's ideas about the connection between the two readings of *-men/-tachi* (i.e., plural and collective readings) and the merging sites of an element to which these plural morphemes are suffixed: [N-*men*] yields the plural reading when it is base-generated in N, and the collective reading when base-generated in the domain of YP.

Li's (1999) idea about the HMC effect on N-raising can be also maintained. For example, the nominal in (27a) is analyzed as in (35):¹⁶

extending it to Japanese, given the overwhelming amount of similarities between *-men* and *-tachi*.

¹⁴ This is in fact a departure from Li's original proposal, since Li does not assume any syntactic dependency between *-men* and a higher functional head (such as D). For her, the definiteness effect arises as *-men* is always suffixed to an element in SpecDP.

¹⁵ This Y head may or may not be identical to X in (17). As pointed out by Huang and Ochi (2011), the postnominal NC nominal in Japanese is typically interpreted as a specific nominal (but not as a definite nominal). YP, the locus of definiteness, may be projecting on top of XP, a possibility that is compatible with the analysis in the main text.

¹⁶ An anonymous reviewer raises the following question: what excludes the derivation in which [N-*men*] first raises to CL and then moves up to Y? Under the standard view of head movement, when a head H moves and adjoins to the next higher head K, the resulting complex head [H-K] is headed by K, and furthermore, it is the complex head [H-K] that moves. Accordingly, when [N-*men*] adjoins to CL, the latter is the head of the complex head. But because CL has no need to move to D, no further movement can take place, on account of familiar reasoning about economy.



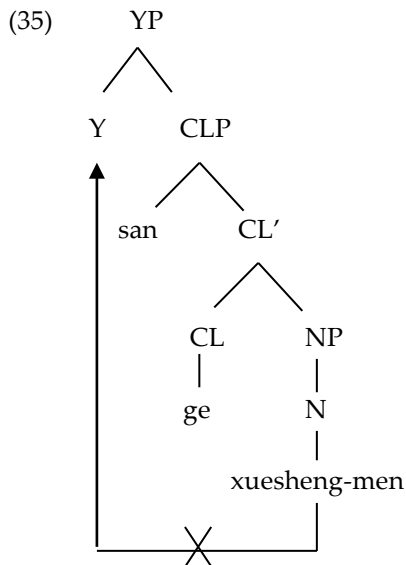

Now, I assume that this covert N-raising is also available in Japanese. (36) illustrates this point for the prenominal NC structure with *-tachi*. Given our earlier assumption that the prenominal NC is an adjunct to NP, it is no surprise that it does not block N-raising (see also Ueda and Haraguchi, 2008 on this point):

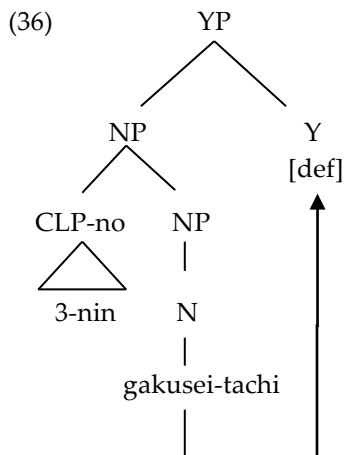

The really interesting issue here is why the postnominal NC and *-tachi* can co-occur, as shown earlier in (27c). Recall our assumption that the postnominal CL structure in Japanese is parallel to the Chinese CL structure: in both structures, the CL head takes an NP as its complement. This is where the alleged overt NP-movement to the edge of the extended noun phrase (as proposed by Watanabe, 2006) plays a vital role. As illustrated in (37), an NP, to whose head *-tachi* is attached, moves out of CLP and lands in the spec of YP, creating a local relation between *-tachi* and the functional head Y. In essence, -





tachi moves as a free rider, carried along with the rest of the NP, which moves for an independent reason (see the discussion in section 4).

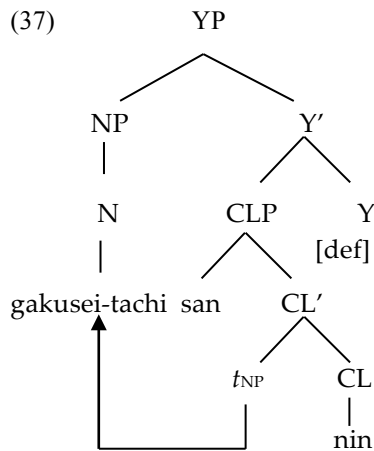

I will now examine (24) and (28). Recall that these examples contrast in terms of available interpretations: the former yields the plural reading whereas the latter yields the collective reading. Li's proposal as summarized in (29), according to which a proper name can be base-generated in SpecDP (or YP for us) or under N, provides an immediate answer. Take (28a) as an example. Along the lines of Li's proposal, I assume that *Xiao Qiang* is base-generated in the spec of YP in this example, and accordingly the collective reading obtains (recall the earlier discussion about the form [pronoun-men]). As shown in (38), *-men* and the head Y can enter into a checking relation "as is". The Japanese examples in (28b, c) can be analyzed essentially in the same fashion.

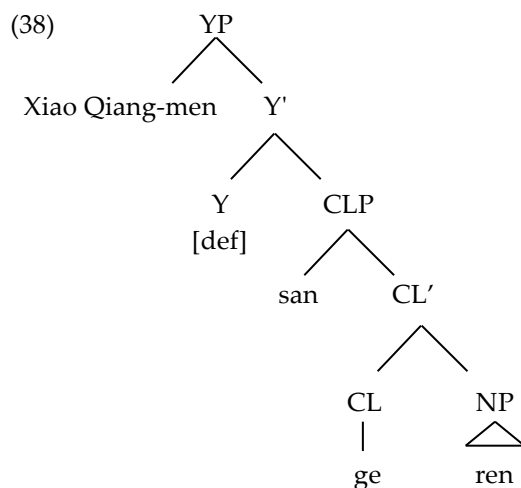

Turning now to (24), the fact that *hanako* is preceded by the prenominal NC *sannin-no* 'three-CL-GEN' indicates that *hanako* is base-generated in N in this case, as illustrated below. As a result, only the plural reading obtains, on a par with examples like (22) with a common noun, *gakusei* 'student'.



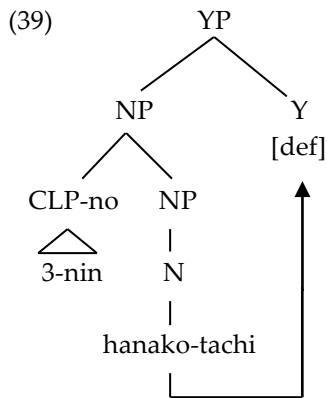

To recap, the postulated NP-movement in the postnominal NC construction accounts for the contrast between (27a) and (27b, c) in purely syntactic terms while maintaining that *-men* and *-tachi* are endowed with the same set of lexical properties: the desired result.

3.4. Prenominal NC vs. postnominal NC

Having provided a piece of potential evidence for the nominal-internal NP-movement in the postnominal NC construction in Japanese, I will now turn to reviewing Huang and Ochi's (2011, 2012) analysis of the paradigms in (13)-(15), starting with (15). On the assumption that the postnominal quantifier is a head selecting a complement to its left, Huang and Ochi analyze the noun phrases in (15a) and (15b) as shown in (40) and (41), respectively. In both cases, the complement of the CL head (i.e., \forall P in (40) and NP in (41)) moves to the edge of the (extended) nominal. Huang and Ochi argue that the unacceptability of (15a) can be traced to the impossibility of having a universal quantifier in the scope of a numeral, as in **ten all dumplings vs. all ten dumplings*.¹⁷ Crucially, this constraint looks at the representation prior to the movement of \forall P in (40).

¹⁷ As a reviewer notes, the paradigms in (13) and (14) remain constant even in the case of a quantifier like *hotondo* 'most' in place of *subete* 'V'. Huang and Ochi's analysis can accommodate this fact: cf. *most of the ten dumplings vs *ten of the most dumplings*.



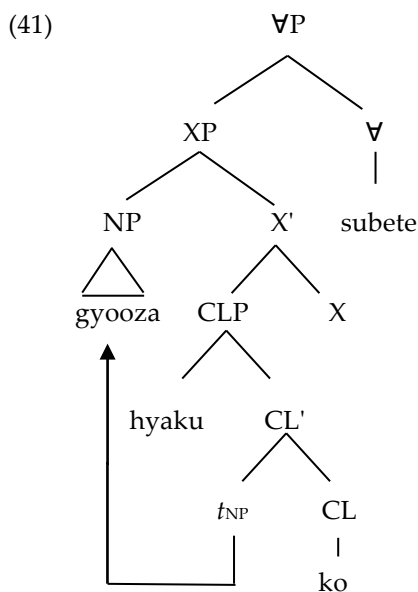
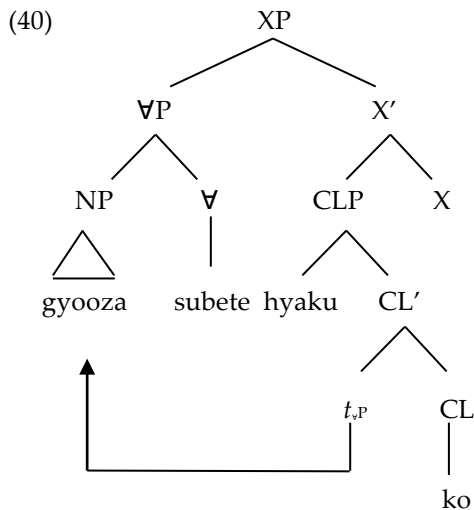

Applying the same logic to examples like (14), Huang and Ochi argue that the contrast here shows that a prenominal element is structurally lower than a postnominal quantifier. The structures of the noun phrases in (14a) and (14b) are shown in (42) and (43), respectively. (14a) is ungrammatical because a universal quantifier originates in a position that is in the scope of a numeral classifier.



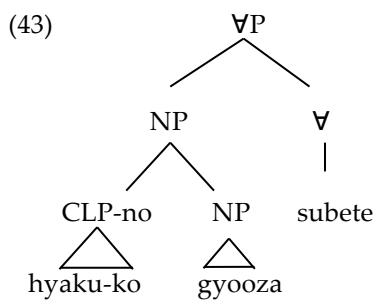
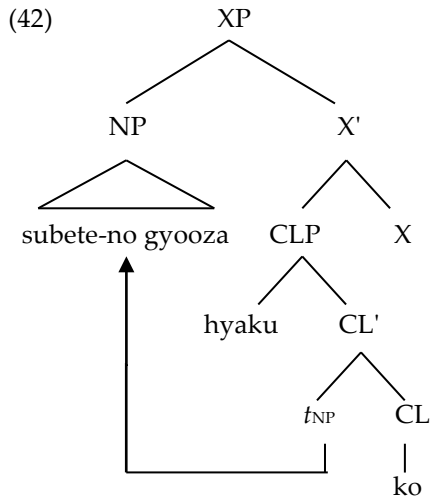

I will henceforth assume, following Huang and Ochi, that a prenominal element is part of an NP whereas a postnominal element is a head taking a complement to its left.

Turning to (13), the ungrammaticality of (13b) is not particularly surprising, given our earlier discussion that a universal quantifier cannot be in the scope of a numeral. On the other hand, (13a) poses interesting questions. Two observations can be made about this example:

- (44) a. It is bad on the reading 'Taro ate all (of the) 100 dumplings.'
 b. It is (marginally) acceptable on the reading 'Taro ate all sets of 100 dumplings.'

I will first consider the point in (44a). Imagine that this example has the structure shown in (45). Nothing that has been said so far precludes this structure: prenominal quantifiers appear within an NP and the universal quantifier is not in the scope of the numeral. What is wrong with this structure?

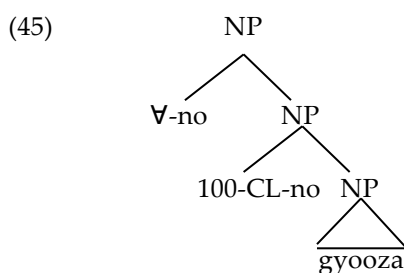



One possibility would be that the prenominal field in Japanese has a flat structure, from which it may follow that *subete* and *100-ko* '100-CL' cannot occur together in the prenominal domain: the resulting nominal expression would be simultaneously assigned two different readings, '100 dumplings' and 'every dumpling,' which may not be permissible.

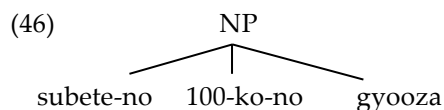

But this line of conjecture is untenable. Consider the following example in (47). As the interpretation indicates, prenominal modifiers are interpreted in a compositional manner: *subete-no* '∀-Gen' quantifies *over linguistics books*, not *over books*, much in line with the structure in (45):

- (47) Taro-wa [subete-no gengogaku-no hon]-o sute-ta.
 Taro-TOP ∀-GEN linguistics-GEN book-ACC throw away-PAST
 'Taro threw away all of the linguistics books'
 (It is not the case that all the books under consideration are linguistics books)

What is wrong with (45) then? Here I would like to capitalize on the fact that the properties of the prenominal *subete* summarized in (44) are shared by *every* in English. Take (48) from Borer (2005: 113). In this example, *every* quantifies not over individuals (i.e., boys) but over sets/groups of boys: there are several groups of three boys and the sharing of a pizza took place within each group.

- (48) Every three boys shared a pizza.

There is another, syntactic point to be noted about this example. Although *every* requires a singular noun (e.g., **every boys*), there does not seem to be one here. Kayne (2007) proposes that examples like (48) in fact contain an abstract singular noun (what he calls NUMBER), as shown in (49), and that this silent noun meets the requirement of *every*.

- (49) Every three NUMBER_{sing} (of) boys shared a pizza

My proposal below exploits Kayne's idea:

- (50) a. Prenominal *subete* '∀' must combine with a singular nominal.
 b. No such restriction applies to the postnominal *subete*.

The idea is that the prenominal *subete* and the postnominal *subete* have different lexical specifications. The former is similar to *every* in English in requiring a singular noun whereas the postnominal *subete* does not have such a requirement (perhaps it requires a plural noun, like *all* in English). The





structure in (45) is illegitimate because of the feature/number incompatibility: while the prenominal *subete* needs a singular noun (phrase), *100-ko-no gyooza* '100-CL-no dumplings' would count as [+ plural], due to the inherent meaning of the numeral *100*. The proposal in (50b) is based on the grammaticality of (14b): the postnominal *subete* has no problem in combining with a noun phrase that contains a prenominal numeral classifier.

A piece of supporting evidence for the hypothesis in (50) comes from the interaction of *subete* and the plural marker *-tachi*. Taking the examples in (51) first, (51a) contains [N-*tachi*]. (51b) and (51c) contain the prenominal *subete* '∀' and the postnominal *subete* '∀', respectively. All of these examples are fine. When *subete* and *-tachi* modify the same nominal, however, a curious contrast emerges. (52b), which has the postnominal *subete*, is fine, whereas (52a) is associated with some degree of degradation for all the speakers I consulted with.

- (51) a. Kono mura-wa dansei-**tachi**-ga 70-sai ijyoo da.
 this village-TOP male-TACHI-NOM 70-years old over be
 'In this village, the males are over 70 years old.'
- b. Kono mura-wa **subete**-no dansei-ga 70-sai ijyoo da.
 this village-TOP ∀-GEN male-NOM 70-years old over be
 'In this village, every male is over 70 years old.'
- c. Kono mura-wa dansei **subete**-ga 70-sai ijyoo da.
 this village-TOP male ∀-NOM 70-years old over be
 'In this village, every male is over 70 years old.'
- (52) a. ?*Kono mura-wa **subete**-no dansei-**tachi**-ga 70-sai ijyoo da.
 this village-TOP ∀-no male-TACHI-NOM 70-years old over be
 'In this village, every male is over 70 years old.'
- b. Kono mura-wa dansei-**tachi** **subete**-ga 70-sai ijyoo da.
 this village-TOP male-TACHI ∀-NOM 70-years old over be
 'In this village, every male is over 70 years old.'

This fact immediately follows from (50). (52a) is degraded because of the number incompatibility: the prenominal *subete* needs to combine with a singular noun (phrase), making it incompatible with [N-*tachi*].¹⁸

¹⁸ A comment may be in order here regarding the alleged incompatibility of the prenominal *subete* and *-tachi*, because a casual Internet search in fact finds a number of counterexamples. However, they are apparently intended as group denoting expressions (e.g., *subete-no dansei-tachi ni sasageru uta* 'a song dedicated to all the men'). The examples in (51) and (52) avoid this complication by using the predicate *70-sai ijyoo da* 'be over 70 years old', thereby forcing the distributive reading.





Turning now to the observation in (44b), I propose that the marginal reading in question comes from an entirely different structure, in which *subete-no* '∀-GEN' modifies not *gyooza* 'dumpling' but a hidden noun with the meaning of 'group' or 'set'.

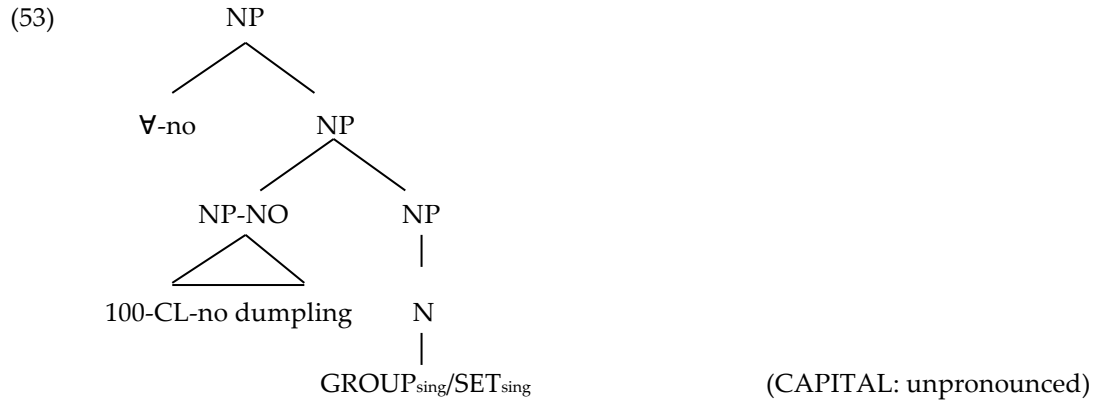

Given the discussion so far, I assume that this abstract/silent noun is singular (analogous to Kayne's NUMBER discussed earlier). No feature/number incompatibility arises in this structure because *subete* and *100-ko* '100-CL' modify different nouns: the latter modifies *gyooza* 'dumpling' whereas the former modifies the (singular) silent noun. In fact, this silent noun can be overtly realized: (54) below has the same meaning as the one reported in (44b).

- (54) *subete-no hyaku-ko-no gyooza-no setto*
 ∀-GEN 100-CL-GEN dumpling-GEN set
 'every set of 100 dumplings'

I believe that the analysis explored here is theoretically significant in at least two respects. First, it shows that although Japanese does not have obligatory morphological markings for the singular vs plural distinction, it is nevertheless sensitive to such a distinction on an abstract level. Second, a non-uniform treatment of the prenominal vs. postnominal NC advocated by Huang and Ochi can be, and should be, extended to other quantifiers, in particular *subete*.

To summarize this section, I first reviewed Huang and Ochi's non-uniform analysis of NCs (and other adnominal quantifiers): the prenominal NC is an NP-adjunct (as in Saito et al's (2008) analysis) while the postnominal NC functions as a head selecting an NP-complement (as in Watanabe's (2006) analysis). I provided a potential support for the NP-movement to the edge of





the extended nominal by comparing the distributions of *-men* in Chinese and *-tachi* in Japanese. I have also provided additional evidence for Huang and Ochi's non-uniform analysis of the prenominal vs. postnominal NC by analyzing the impossibility of having both a universal quantifier and an NC in the prenominal domain. I am now ready to return to the question about the prestranding source of the floating UNQ in Japanese.

4. UNQ in Japanese revisited

Recall that a numeral classifier and a universal quantifier can co-occur within the same nominal domain in the following two cases: (i) when the former occurs prenominally and the latter postnominally as in (14b), and (ii) when both occur postnominally, with the former preceding the latter, as shown in (15b).

I would like to start the discussion by reviewing Huang and Ochi's discussion of basic paradigms like the one in (11), repeated below as (55).

- (55) a. Taro-wa **jyu-ko-no** (*kinoo) gyooza-o (kinoo) tabe-ta.
 Taro-TOP 10-CL-GEN yesterday dumpling-ACC yesterday eat-PAST
 'Taro ate 10 dumplings (yesterday).'
- b. Taro-wa gyooza (*kinoo) **jyu-ko-o** (kinoo) tabe-ta.
 Taro-TOP dumpling yesterday 10-CL-ACC yesterday eat-PAST
 'Taro ate 10 dumplings (yesterday).'
- c. Taro-wa gyooza-o (kinoo) **jyu-ko** tabe-ta.
 Taro-TOP dumpling-ACC yesterday 10-CL eat-PAST
 'Taro ate 10 dumplings.'

Huang and Ochi argue that the stranded NC in (55c) is related to the postnominal NC in (55b) and not to the prenominal NC in (55a). Their main arguments are as follows: first, once the hypothesis that a prenominal NC is part of NP (which is the lowest maximal projection in the extended noun phrase) is endorsed, one should not expect a movement operation to be able to affect NP to the exclusion of a prenominal NC: a syntactic operation affects a maximal projection or a head, but not a segment of a projection. Second, Jenks's (2011) cross-linguistic generalization summarized below contains the implication that postnominal NCs, not prenominal NCs, should be involved in stranding.

- (56) Only those classifier languages that have (or allow) the Noun-NC order allow NC-float (Head-final languages: Burmese, Japanese, and Korean; head-initial languages: Thai, Khmer).





Furthermore, recent studies such as Sauerland and Yatsushiro (2004) and Miyamoto (2009) converge on the idea that prenominal NCs should be treated separately from postnominal NCs and floating NCs.

Huang and Ochi's specific proposal is as follows: the postnominal NC and the stranded NC come from the same underlying structure and both involve NP-movement. However, an NP ends up in different positions, inside or outside the nominal domain. Recall that Huang and Ochi essentially follow Watanabe (2006) (as I do in this paper) and assume that the postnominal NC has the structure in (17), repeated below. NP ends up at the left edge of the nominal domain in this case, and Case is assigned to the whole nominal expression (XP).

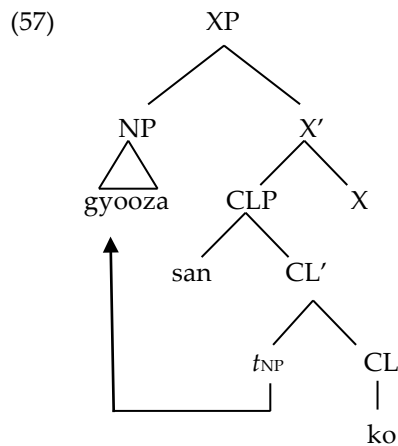

If, on the other hand, an NP ends up moving out of the nominal domain, the stranded NC obtains. In this case, Case is assigned to the extracted NP:¹⁹

¹⁹ For reasons relating to interpretive differences between the post-nominal NC and the stranded NC (i.e., specificity), Huang and Ochi (2011, 2012) propose that the stranded NC construction lacks the XP layer, but details need not concern us here. Note also that although (58) shows a structure in which NP moves into a VP domain, NP may move up further.



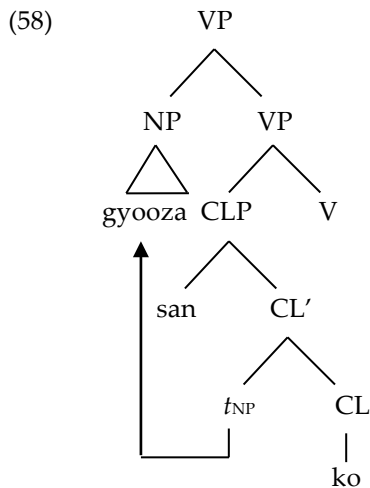

Two points are worth discussing here. First, a reviewer asks why Case is manifested on different phrases in the two constructions. Huang and Ochi's (2011, 2012) take on this issue rests on the NP vs DP parameter discussed by Chierchia (1998a, b) and Bošković (2008). According to this hypothesis, classifier languages such as Chinese and Japanese are categorized as NP-languages. Huang and Ochi's overall analysis is not quite compatible with this hypothesis, since these languages may manifest some functional projections on top of NP, such as CL and X (whose identity remains unknown): see, for example, the structures in (17b) and (21). While rejecting this semantic parameter in its strongest form, Huang and Ochi entertain a somewhat weaker version of this hypothesis. In particular, Huang and Ochi suggest that these classifier languages may be 'disguised' NP-languages. Although languages like Chinese and Japanese may optionally realize non-lexical projections in the nominal domain, what really matters for their syntax is in fact an NP: it is an NP, and not the whole nominal expression, that serves as a syntactic argument, entering into Agree relations and so on. The extra, non-lexical projections, while contributing to semantic interpretations (as in the case of a classifier, by creating units for counting), are 'extra baggage' that sometimes comes with an NP, hampering the syntactic relation between an NP and external probes such as *v* and T and forcing the movement of N(P). Under this line of analysis, the fact that Case is manifested on an NP, as in the floating NC construction, is expected. As for the postnominal NC construction, Huang and Ochi speculate that the whole nominal expression, by virtue of hosting an NP in its specifier/edge, continues to serve as the extended nominal projection, thereby manifesting





Case properties (XP may inherit Case values from the NP sitting in its specifier, via spec-head agreement and so on).

Second, this analysis captures the well-known fact that the associate of an NC cannot appear inside a PP (thanks to a reviewer for raising this issue):

- (59) a. taro-wa gakusei san-nin to atta.
 Taro-TOP student three-CL with met
 'Taro met with three students.'
- b. *taro-wa gakusei to san-nin atta.
 Taro-TOP student with three-CL met
 'Taro met with three students.'

Under Huang and Ochi's analysis, the floating NC construction involves movement of an NP out of the extended nominal, not the movement of a numeral classifier. (59a) can be derived in the manner shown in (60). Crucially, however, the word order in (59b) cannot be generated:

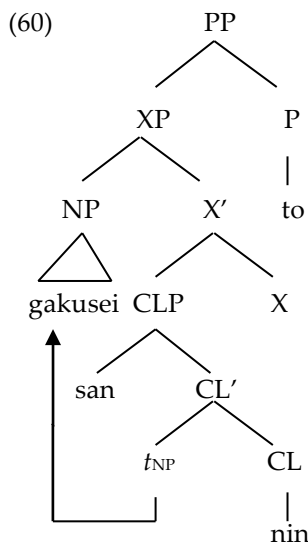

I will now extend Huang and Ochi's analysis to the UNQ construction in Japanese. Once this step is taken, the logical conclusion is that the pre-stranding source of the floating UNQ is of the type illustrated in (15b). I will thus refer to the type in (15b) as the UNQ in Japanese. Two points are worth noting here: first, recall the contrast between (7) and (8), which shows that the order between CL and the universal quantifier *subete* is fixed. The contrast between (15a) and (15b) shows that the same is true in the postnominal domain. Second, recall also that the floating UNQ is incompatible with a partitive interpretation (see (10c)). This property is also shared by the postnominal NC (see Nakanishi 2006), and not surprisingly, by the UNQ pattern in (15b). The following example, which is





similar to (10c) but involves a postnominal UNQ instead of a floating UNQ, is ungrammatical, with or without the universal quantifier *subete*:

- (61) *taro-wa tsukue-ni aru hyaku-ko-no gyooza sanjyu-ko (subete)-o tabeta.
 Taro-TOP table-DAT be 100-CL-GEN dumpling 30-CL \forall -ACC eat-PAST
 'Taro ate (all of the) 30 dumplings out of the 100 dumplings on the table'

5. Partitives in Japanese

Although I take the nominal form in (15b) to be the underlying source of the floating UNQ, some additional possibilities need to be taken into consideration, in particular the partitive construction, which has the general form of *NP-no Q 'NP-GEN Q'*:²⁰

- (62) a. taro-wa tsukue-ni aru gyooza-no (uchi-no) san-ko- tabe-ta.
 Taro-TOP table-DAT be dumpling out-of 3-CL-ACC eat-PAST
 'Taro ate three of the dumplings on the table.'
 b. taro-wa tsukue-ni aru gyooza-no subete-o tabe-ta.
 Taro-TOP table-DAT be dumpling-GEN \forall -ACC eat-PAST
 'Taro ate all of the dumplings on the table.'

The syntactic structure of the partitive construction in Japanese has not been investigated in any depth in the literature (see however Sauerland and Yatsushiro, 2004 and Watanabe, 2008), and I have nothing new to add here. In any case, because NCs and *subete* ' \forall ' can occur in the partitive construction on their own, several variants of (15b) need to be considered. (63a) is identical to (15b), with the phrase *NP+ 100-ko subete*. The form in (63b) is an instance of its partitive variant, with *-no (uchi-no) '-GEN (out-of)'* inserted between *gyooza* 'dumpling' and *hyaku-ko* '100-CL', although the example is somewhat degraded.²¹ The pattern shown in (63c) is another partitive variant, with *-no '-GEN'* occurring between *hyaku-ko* '100-CL' and *subete* ' \forall .'²²

²⁰ For some speakers, the phrase *uchi-no* 'out-of' is obligatory when Q is an NC (see Kawashima, 1994; Watanabe, 2008). Although I share this judgment, its absence would not lead to total unacceptability for me. On the other hand, this phrase seems unwanted when Q is a universal quantifier, as shown in (i) below, which may be an indication that *uchi-no* demands a proper subset relation.

(i) taro-wa tusukue-ni aru gyooza-no uchi-no ooku/hotondo/?subete-o tabeta.
 Taro-TOP table-DAT be dumpling-GEN out-of many/most/ \forall -ACC eat-PAST
 'Taro ate many/most/all of the dumplings on the table.'

²¹ As mentioned in the previous footnote, NCs in partitive constructions (tend to) require the phrase *uchi-no* 'out-of', which demands a proper subset relation. But there





- (63) a. taro-wa tsukue-ni aru gyooza **hyaku-ko subete**-o tabe-ta.
 Taro-TOP table-DAT be dumpling 100-CL \forall -ACC eat-PAST
 '(lit.) Taro ate all 100 dumplings on the table.'
- b. ?taro-wa tsukue-ni aru gyooza-no (uchi-no) **hyaku-ko subete**-o
 Taro-TOP table-DAT be dumpling-GEN out-of 100-CL \forall -ACC
 tabe-ta.
 eat-PAST
 '(lit.) Taro ate all 100 of the dumplings on the table.'
- c. taro-wa tsukue-ni aru gyooza **hyaku-ko-no subete**-o tabe-ta.
 Taro-TOP table-DAT be dumpling 100-CL-GEN \forall -ACC eat-PAST
 '(lit.) Taro ate all of the 100 dumplings on the table.'

Although (63b) is somewhat degraded, I will keep it in the discussion, for the sake of completeness. Now I will provide two arguments to suggest that the floating UNQ should be related to the nominal type in (63a) (and (63b)) but not to the one in (63c). First, recall that the Q of the floating UNQ in Japanese is restricted to a universal quantifier (see (9b)). This restriction applies to the type in (63a) (and (63b)), but not to the one in (63c). This point can be highlighted by the data in (64), which are minimally different from (63) in employing *hotondo* 'most' instead of *subete* ' \forall '.

- (64) a. *Taro-wa tsukue-ni aru gyooza **hyaku-ko hotondo**-o tabe-ta.
 Taro-TOP table-DAT be dumpling 100-CL most-ACC eat-PAST
 '(lit.) Taro ate most 100 dumplings on the table.'
- b. *Taro-wa tsukue-ni aru gyooza-no (uchi-no) **hyaku-ko**
 Taro-TOP table-DAT be dumpling-GEN out-of 100-CL
hotondo-o tabe-ta.
 most-ACC eat-PAST
 '(lit.) Taro ate most 100 of the dumplings on the table.'
- c. Taro-wa tsukue-ni aru gyooza **hyaku-ko-no hotondo**-o tabe-ta.
 Taro-TOP table-DAT be dumpling 100-CL-GEN most-ACC eat-PAST
 '(lit.) Taro ate most of the 100 dumplings on the table.'

Second, the floating UNQ in Japanese does not permit *-no* between the NC and *subete* ' \forall ', which would be puzzling if it were related to the form in (63c).

- (65) Taro-wa tsukue-ni aru gyooza-o sono toki **hyaku-ko(*-no) subete**
 Taro-TOP table-DAT be dumpling-ACC that time 100-CL-GEN \forall
 tabe-ta.
 eat-PAST
 'Taro ate all of the 100 dumplings that were on the table at that time.'

is no proper subset relation in this example, due to the presence of *subete* ' \forall '. This conflict may be a factor behind the slight deviance of this example.

²² Alternatively, *-no* may be a postposition.





On the basis of these arguments, I would like to identify the pattern in (63a) (=15b)) (and the one in (63b), to the extent that it is acceptable) as the prestranding structure of the floating/stranded UNQ. See (41) for the relevant structure.

The above conclusion is in line with Cirillo's characterization of the UNQ in Romance and Germanic. As discussed by Cirillo, a noun phrase hosting a universal quantifier and a numeral in its extended domain does not necessarily count as the UNQ. Consider again the Dutch example in (2a), repeated below as (66a). Notice that the word order within the subject is \forall +numeral+de+noun (phrase). In particular, *de* 'the' occurs following the numeral. Along with this word order, Dutch allows another word order shown in (67a), in which *de* 'the' appears between a universal quantifier and a numeral. The two cases in (66a) and (67a) differ in terms of their floating variants, shown in (66b) and (67b), respectively.

- (66) a. **Alle drie** de studenten hebben het boek gelezen.
 all three the students have the book read
 b. De studenten hebben **alle drie** het boek gelezen.
 the students have all three the book read
- (67) a. **Al de drie** studenten hebben het boek gelezen.
 \forall the three students have the book read
 b. De **drie** studenten hebben **allen** het boek gelezen.
 the three students have \forall the book read

Following Cirillo, I assume that (66a) is an example of the UNQ construction while (67a) belongs to a more familiar construction where a universal quantifier selects the definite DP which contains a numeral, e.g., *all (of) the three students*. Notice that only the universal quantifier is stranded in (67b). I suggest that the Japanese example in (63c) corresponds to (67a) in Dutch. (68) is a floating/stranded version of (63c), corresponding to the Dutch example in (67b):

- (68) taro-wa tsukue-ni aru gyooza **hyaku-ko-o** (kinoo) **subete** tabe-ta.
 Taro-TOP table-DAT be dumpling 100-CL-ACC yesterday \forall eat-PAST
 '(lit.) Taro ate all of the 100 dumplings on the table (yesterday).'





The adnominal UNQ construction in Dutch (66a) has a definite article following the numeral. Although Japanese does not manifest an overt definite determiner, one can assume that this property holds in cases like (63a).²³

Now one important theoretical consequence of the whole discussion may be addressed. Consider again (65). The fact that *-no* cannot be present in the floating UNQ construction militates against analyzing the floating UNQ in terms of the Doetjes/Fitzpatrick analysis introduced at the outset of this paper. The following example, which contains adnominal (i.e., non-floating) UNQs helps highlight this important point:

- (69) a. taro-wa toshokan-ni aru hon **hyaku-satsu(-no)** **subete**-o yonda.
 Taro-Toplibrary-Dat be book 100-CL(-Gen) **∀**-Acc read
 b. jiro-mo **hyaku-satsu(-no)** **subete**-o yonda.
 Jiro-also 100-CL(-Gen) **∀**-Acc read
 (Lit.) 'Taro read all of the 100 books that were in the library. Jiro also read all.'

(69b) shows that the NP part of the adnominal UNQ can be phonologically null, whether or not the genitive marker *-no* is present between the postnominal NC and the universal quantifier *subete*. I assume that the NP-slot is occupied by *pro* in such cases:²⁴

- (70) jiro-mo [_{VP} [_{CLP} [_{NP} *pro*] **hyaku-satsu(-no)**] **subete**]-o yonda

(65) may now be considered in this light. If the Doetjes/Fitzpatrick type analysis were indeed available for the floating UNQ in Japanese, the presence or absence of *-no* should make no difference, since the floating UNQ is a nominal element containing *pro* under the Doetjes/Fitzpatrick analysis. What would be wrong with the following structure?

- (71) *Taro-wa tsukue-ni aru gyooza-o sono toki
 Taro-TOP table-DAT be dumpling-ACC that time
 [_{VP} [_{CLP} [_{NP} *pro*] hyaku-ko-no] **subete**] tabe-ta.
 100-CL-GEN **∀** eat-PAST

Of course, in order for this argument to go through, the stranding (i.e., sub-extraction) approach would have to be able to explain why the presence of *-no*

²³ Due to the lack of an overt definite article, this example may in fact be ambiguous between the UNQ construction ('all 100 of the dumplings') and the more familiar structure ('all of the 100 dumplings').

²⁴ Alternatively, this could be a case of 'argument ellipsis' (see Oku, 1998 and Saito, 2007). Nothing hinges on the choice between the two.



in the postnominal domain blocks extraction in examples like (65). To make the issue clear, compare the two structures in (72). Why is it that NP-extraction out of the nominal domain is possible in the configuration shown in (72a), but not in (72b)?

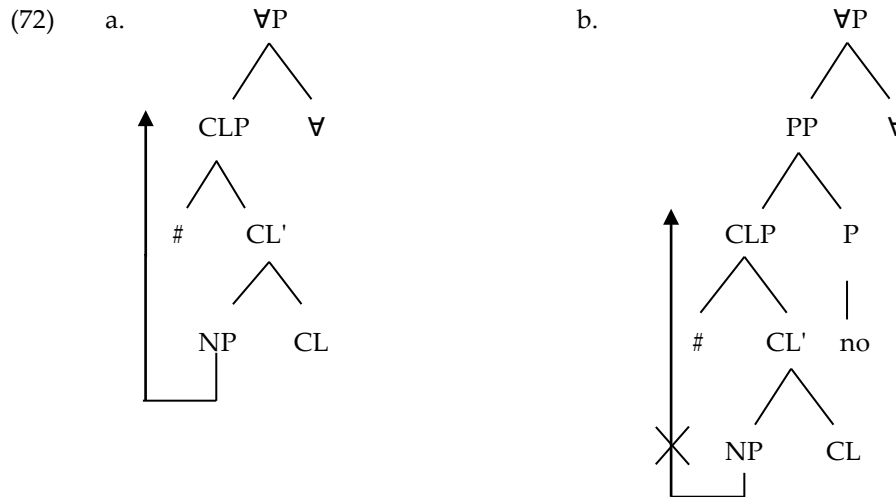

I tentatively assume that *-no* is a postposition, as indicated in (72b), although the following argument would not be affected if *-no* is analyzed as an overt manifestation of the genitive Case. What is crucial here is that CLP in (72b) is assigned Case, either oblique (if *-no* is a postposition) or genitive. Crucially, CLP is assigned Case precisely because it is an 'extended projection' of NP. Now suppose that the NP-movement involved in deriving the stranded NC (as well as the postnominal NC) is driven for Case reasons (as Huang and Ochi speculate). It then follows that NP has no reason to move out in the configuration in (72b): its Case property is satisfied 'in-situ', with its extended projection (CLP) receiving Case from *-no*. According to familiar economy reasoning, this movement cannot therefore take place. The stranding approach therefore has a clear way to predict the ungrammaticality of (65) in the presence of *-no* in the postnominal field. Together with Cirillo's example in (4b), the evidence presented here leads to the conclusion that the floating UNQ should be analyzed in terms of stranding.²⁵

²⁵ As a reviewer notes, the discussion in this section does not immediately lead to the conclusion that the floating UNQ should be uniformly analyzed as stranding across languages, since the evidence presented here rests on a specific property of Japanese (i.e., the distribution of *-no*). While this point is well made, I think that a unified view of this construction is the strongest option, unless empirical evidence





6. Conclusion

I have argued in this paper that Japanese has the adnominal and floating UNQ construction in the sense of Cirillo (2010). Building on Huang and Ochi's analysis of the adnominal numeral classifier and the adnominal universal quantifier, I argued that the floating UNQ is transformationally related to the postnominal NC+ \forall form (see (63a)), and that even the Doetjes/Fitzpatrick type analysis cannot adequately handle some Japanese data without additional assumptions. Note that my goal in this paper has been fairly modest. I did not in any way mean to claim that all the instances of floating classifiers/quantifiers involve stranding. Rather, my claim is that there is a subspecies of the floating quantifier construction, i.e. the floating UNQ construction, which must be understood in terms of stranding.

Let me end this paper with one final word about the internal structure of the UNQ. As shown in (41), I have argued that a universal quantifier acts as the head of the entire nominal expression. This proposal is actually a departure from Cirillo's original analysis that a universal quantifier and a numeral form a complex head which is base-generated as such. However, as shown in (73) below, the three components of the UNQ (i.e., NP, NC and \forall) could be split off from each other (although such examples sound somewhat degraded), which is an indication that we are dealing with a series of phrasal elements.

- (73) ?gyooza-o kinoo **hyaku-ko** taro-ga **subete** tabe-ta (koto)
 dumpling-ACC yesterday 100-CL Taro-NOM \forall eat-PAST fact
 '(the fact that) Taro ate all of the five dumplings yesterday'

In fact, Corver (2010) presents interesting evidence to show that the \forall +Numeral part of the UNQ construction in Germanic/Romance is phrasal. A unified analysis of the UNQ construction therefore seems feasible.

dictates otherwise. Further investigations should be able to shed more light on this issue.





REFERENCES

- Bale, Alan & Hrayr Khanjian. 2008. Armenian classifiers and number marking, poster presented at *SALT XVIII*.
- Bobaljik, Jonathan. 2004. Floating quantifiers: Handle with care. In Lisa Cheng & Rint Sybesma (eds.), *The Second Glot International State-of-the-Article Book*. 107-148. Mouton de Gruyter.
- Borer, Hagit. 2005. *In Name Only*. Oxford: Oxford University Press.
- Bošković, Željko. 2004. Be careful where you float your quantifiers. *Natural Language and Linguistic Theory* 22, 681–742.
- Bošković, Željko. 2008. What will you have, DP or NP? *Proceedings of NELS 37*. 101–114. GLSA, University of Massachusetts, Amherst.
- Cheng, Lisa & Rint Sybesma. 1999. Bare and not-so-bare nouns and the structure of NP. *Linguistic Inquiry* 30, 509-542.
- Chierchia, Gennaro. 1998a. Plurality of mass nouns and the notion of “semantic parameter”. In Susan Rothstein (ed.), *Events and Grammar*. 53–103. Dordrecht: Kluwer Academic Publishers.
- Chierchia, Gennaro. 1998b. Reference to kinds across languages. *Natural Language Semantics* 6, 339–405.
- Cinque, Guglielmo. 1994. On the evidence for partial N-movement in the Romance DP. In Cinque, G., Koster, J., Pollock, J.-Y., Rizzi, L., & Zanuttini, R. (eds.), *Paths Towards Universal Grammar: Studies in Honor of Richard S. Kayne*. 85–110. Washington: Georgetown University Press.
- Cinque, Guglielmo. 2010. *The Syntax of Adjectives*. Cambridge, MA: MIT Press.
- Cirillo, Robert. 2010. Issues in the study of floating universal numeric quantifiers. *Linguistics* 48 (3), 573–601.
- Corver, Norbert. 2010. Dressed numerals and the structure of universal numeric quantifiers. In J.-W. Zwart & M. de Vries (eds.), *Structure Preserved: Studies in Syntax for Jan Koster*. 91–99. Amsterdam: John Benjamins.
- Doetjes, Jenny. 1997. *Quantifiers and Selection: On the Distribution of Quantifying Expressions in French, Dutch, and English*, HIL Dissertations. The Hague.
- Giusti, Giuliana. 1991. The categorical status of quantified nominals. *Linguistische Berichte* 136, 438-452.
- Fitzpatrick, Justin. 2006. *The Syntactic and Semantic Roots of Floating Quantification*. Cambridge, MA: MIT dissertation.
- Huang, C.-T. James, Y.-H. Audrey Li, & Yafei Li. 2009. *The Syntax of Chinese*. Cambridge.





- Huang, C.-T. James & Masao Ochi. 2011. Classifiers and nominal structure: A parametric approach and its consequences. *Proceedings of GLOW in Asia VIII*, 191–197, Beijing Language and Culture University Press.
- Huang, C.-T. James & Masao Ochi. 2012. *Remarks on Classifiers and Nominal Structure in East Asian*. Ms., Harvard University and Osaka University.
- Ijic, Robert. 1994. Quantification in Mandarin Chinese: Two markers of plurality. *Linguistics* 32, 91–116.
- Inoue, Kazuko. 1978. *Nihongo-no Bunpoo Kisoku*. Tokyo: Taishukan.
- Jenks, Peter. 2011. Thai quantifier float as quantifier raising. *Proceedings of GLOW-in-Asia VIII*, 198–204, Beijing Language and Culture University Press.
- Kawashima, Ruriko. 1994. *The Structure of Noun Phrases and the Interpretation of Quantificational NPs in Japanese*, Doctoral dissertation, Cornell University.
- Kawashima, Ruriko. 1998. The structure of extended nominal phrases: The scrambling of numerals, approximate numerals, and quantifiers in Japanese. *Journal of East Asian Linguistics* 7, 1–26.
- Kayne, Richard. 2007. Several, few and many. *Lingua*, 117(5), 832–858.
- Koizumi, Masatoshi. 2000. String vacuous overt verb raising. *Journal of East Asian Linguistics* 9, 227–285.
- Kurafuji, Takeo. 2004. Plural morphemes, definiteness, and the notion of semantic parameter. *Language and Linguistics* 5 (1), 211–242.
- Li, Y.-H. Audrey. 1998. Argument determiner phrases and number phrases. *Linguistic Inquiry* 29, 693–702.
- Li, Y.-H. Audrey. 1999. Plurality in classifier language. *Journal of East Asian Linguistics* 8, 75–99.
- Miyagawa, Shigeru. 1989. *Structure and Case Marking in Japanese*. New York: Academic Press.
- Miyamoto, Yoichi. 2009. On the nominal-internal distributive interpretation in Japanese. *Journal of East Asian Linguistics* 18, 233–251.
- Murasugi, Keiko. 1991. *Noun Phrases in Japanese and English: a Study in Syntax, Learnability and Acquisition*, Ph.D. dissertation, University of Connecticut, Storrs.
- Nakanishi, Kimiko. 2007. *Formal Properties of Measurement Constructions*. Berlin: Mouton de Gruyter.
- Nakanishi, Kimiko & Satoshi Tomioka. 2004. Japanese plurals are exceptional. *Journal of East Asian Linguistics* 13, 113–140.
- Oku, Satoshi. 1998. *A Theory of Selection and Reconstruction in the Minimalist Perspective*, Ph.D. dissertation, University of Connecticut, Storrs.





- Saito, Mamoru. 2007. Notes on East Asian argument ellipsis. *Language Research* 43, 203–227.
- Saito, Mamoru., T.-H. Jonah Lin, & Keiko Murasugi. 2008. N'-Ellipsis and the structure of noun phrases in Chinese and Japanese. *Journal of East Asian Linguistics* 17, 247–271.
- Sauerland, Uli & Kazuko Yatsushiro. 2004. A silent noun in partitives, *Proceedings of NELS* 34, 101–112.
- Shlonsky, Ur. 2004. The form of Semitic noun phrases. *Lingua* 114 (12), 1465–1526.
- Sportiche, Dominique. 1988. A theory of floating quantifiers and its corollaries for constituent structure. *Linguistic Inquiry* 19 (2), 425–451.
- Tang, C.-C. Jane. 1990. *Chinese Phrase Structure and the Extended X-bar Theory*, Ph.D. dissertation, Cornell University, Ithaca.
- Ueda, Yasuki & Tomoko Haraguchi. 2008. Plurality in Japanese and Chinese, *Nanzan Linguistics: Special Issue* 3 (2), 229–242.
- Watanabe, Akira. 2006. Functional projections of nominals in Japanese: Syntax of classifiers. *Natural Language and Linguistic Theory* 24, 241–306.
- Watanabe, Akira. 2008. The structure of DP. In S. Miyagawa & M. Saito (eds.), *Oxford Handbook of Japanese Linguistics*. 513–540. New York: Oxford University Press.

Reception date/Fecha de recepción/Data de recepção: 02/06/2012

Revision date/Fecha de revisión/Data de revisão: 09/09/2012

Acceptation date/Fecha de aceptación/Data de aceitação: 16/09/2012

Masao Ochi

ochi@lang.osaka-u.ac.jp

Osaka University

