

PUBLISHED BY

# INTECH

open science | open minds

World's largest Science,  
Technology & Medicine  
Open Access book publisher



**3,350+**  
OPEN ACCESS BOOKS



**108,000+**  
INTERNATIONAL  
AUTHORS AND EDITORS



**114+ MILLION**  
DOWNLOADS



**BOOKS**  
DELIVERED TO  
151 COUNTRIES

AUTHORS AMONG  
**TOP 1%**  
MOST CITED SCIENTIST



**12.2%**  
AUTHORS AND EDITORS  
FROM TOP 500 UNIVERSITIES



Selection of our books indexed in the  
Book Citation Index in Web of Science™  
Core Collection (BKCI)

**WEB OF SCIENCE™**

Chapter from the book *New Approach of Indoor and Outdoor Localization Systems*  
Downloaded from: <http://www.intechopen.com/books/new-approach-of-indoor-and-outdoor-localization-systems>

Interested in publishing with IntechOpen?  
Contact us at [book.department@intechopen.com](mailto:book.department@intechopen.com)

---

# GNSS in Precision Agricultural Operations

---

Manuel Perez-Ruiz and Shrini K. Upadhyaya

Additional information is available at the end of the chapter

<http://dx.doi.org/10.5772/50448>

---

## 1. Introduction

Today, there are two Global Navigation Satellite Systems (GNSS) that are fully operational and commercially available to provide all-weather guidance virtually 24 h a day anywhere on the surface of the earth. GNSS are the collection of localization systems that use satellites to know the location of a user receiver in a global (Earth-centered) coordinate system and this has become the positioning system of choice for precision agriculture technologies. At present North American Positioning System known as Navigation by Satellite Timing and Ranging Global Position System (NAVSTAR GPS or simply GPS) and Russian Positioning System known as *Globalnaya Navigatsionnaya Sputnikovaya Sistema* or Global Navigation Satellite System (GLONASS) both qualify as GNSS. Two other satellite localization systems, Galileo (European Union) and Compass (Chinese), are expected to achieve full global coverage capability by 2020. Detailed information on GNSS technology is plentiful, and there are many books that provide a complete description of these navigation systems [9-11]. But the focus of this chapter is on the applications of GPS in agricultural operations. These applications include positioning of operating machines, soil sampling, variable rate application and vehicle guidance.

The basic principle of operation on which GNSS systems is based is often referred to as resection (also called triangulation), and it involves estimating the distances from at least three satellites orbiting the Earth along different and sufficiently separated trajectories to determine the position of an object in 2-D along with the uncertainty in measurement. Typically, each GPS satellite continuously transmits at least two carrier waves consisting of two or more codes, and a navigation message. GNSS receivers measure the time it takes for the signal to travel from the transmitter on the satellite to the receptor in the receiver antenna and use that time to calculate the distance (or range) between them. To perform a positioning or navigation task, a GNSS receiver must lock onto the signals from at least three satellites to calculate a two-dimensional (2D) position (latitude and longitude). If four or more satellites are in view, the receiver can determine three-dimensional (3D) position (latitude, longitude, and altitude) of the user.

Bibliography on GNSS systems is rich, and there are many monographs that provide a full description of these navigation systems [9-11]. However, the authors have decided to focus this chapter on the precision agricultural applications of GNSS receivers due to its popularity in this field in recent years.

## 2. GPS system

The North American GPS consists of 24 operational satellites (+some spares) in six orbits (A-F). Normally 4 to 10 satellites can be seen anywhere in the world with an elevation mask of 10 degrees. These orbits are nearly circular with an elevation of 20,200 km and an eccentricity of less than 1%. The orbital period is 11 hours and 58 minutes. This means that these satellites go around the Earth two times a day. The orbits are inclined at 55 degrees to the equatorial plane. The satellites have orbital speeds of about 3.9 km/s in an Earth-centered non rotating coordinate frame of reference. This system was completed in 1993 and became fully operational in 1995.

The current GPS consists of three major segments- space, control and user. The space segment consists of 24 operational satellites plus additional spares (- 8 at present). Control segment consists of worldwide network of tracking stations and a Master Control Station (MCS) to track the satellites in order to predict their exact locations, almanac and ephemeris, obtain data related to satellite integrity, satellite clocks, atmospheric data, etc., and upload the information to GPS satellites. The user segment consists of GPS receivers.

Figure 1 shows a typical GPS satellite with L- and S- band antennas. These satellites transmit positioning signals using L- band and S- band is used for uploading almanac and ephemeris data to the satellites from uplink stations. Table 1 lists the current GPS constellation. Note that the system consists of IIR, IIRM, and IIF satellites (-These are different generation satellites with different specifications and capabilities). Each satellite is recognized by a pseudo random number (PRN) or a space vehicle number (SVN). Note that PRN is not at all random and is generated by a complex mathematical algorithm to identify a given satellite. Table 1 includes the launch date of each satellite and the orbit in which it is located. Since timing is the key for receiver position determination as will be described later, each satellite is equipped with three to four atomic clocks.

The control segment consists of 12 tracking stations with the master control station located in Colorado Springs, CO, USA. All stations are unmanned and they transmit data to the master control station by satellite communication. Four of the 12 stations have the uplink capabilities and can upload almanac, ephemeris and other relevant information to satellites.

As mentioned earlier, GPS receivers constitute the user segment. These can consist of simple and inexpensive receivers costing only about \$100 to 150 or very expensive receivers costing thousands of dollars that provide high positioning accuracy. The positioning accuracy of inexpensive receivers may be about 10 m without any correction and can be improved to about 3m with satellite based wide area correction. The more expensive receivers can provide centimeter level positioning accuracy. While most receivers use pseudo-ranging technique to determine their location, more expensive receivers employ carrier phase measurement to provide centimeter level accuracy.

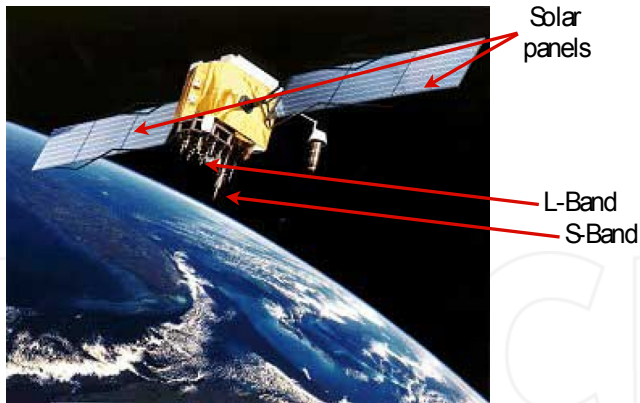

**Figure 1.** A typical IIF GPS satellite with L-and S- band antennas. (Source: <http://www.kowona.de/en/gps/>)

Satellites	PRN	SVN	Launch Date	Plane
IIR-2	13	43	23 Jul 1997	F3
IIR-3	11	46	07 Oct 1999	D5
IIR-4	20	51	11 May 2000	E1
IIR-5	28	44	16 Jul 2000	B3
IIR-6	14	41	10 Nov 2000	F1
IIR-7	18	54	30 Jan 2001	E4
IIR-8	16	56	29 Jan 2003	B1
IIR-9	21	45	31 Mar 2004	D3
IIR-10	22	47	21 Dec 2003	E2
IIR-11	19	59	20 Mar 2004	C3
IIR-12	23	60	23 Jun 2004	F4
IIR-13	2	61	06 Nov 2004	D1
IIR-14M	17	53	26 Sep 2005	C4
IIR-15M	31	52	25 Sep 2006	A2
IIR-16M	12	58	17 Nov 2006	B4
IIR-17M	15	55	17 Oct 2007	F2
IIR-18M	29	57	20 Dec 2007	C1
IIR-19M	7	48	15 Mar 2008	A4
IIR-20M*		49	24 Mar 2009	
IIR-21M	05	50	17 Aug 2009	E3
IIF-1	25	62	28 May 2010	B2
IIF-2	01	63	16 Jul 2011	D2

Satellite is no longer in service

**Table 1.** GPS constellation as of January 2012 (Source: <ftp://tycho.usno.navy.mil/pub/gps/gpsb2.txt>)

### 3. GLONASS system

GLONASS (Global Navigation Satellite System) was developed by former Soviet Union in 1980s almost in parallel with the United States and is now operated for the Russian government by the Russian Space Force. The original GLONASS constellation was completed in 1995, but then the unstable economic situation following the collapse of the former Soviet Union led to the deterioration of this satellite constellation. In December 2011 the GLONASS achieved full global coverage for the second time (27 satellites, 24 operational and 3 in reserve). These satellites are located in medium Earth orbits (MEO) at 19,100 km altitude with a 64.8 degrees inclination and a period of 11 hours and 15 minutes. This constellation operates in three orbital planes, with 8 evenly spaced satellites in each.

### 4. Galileo system

Galileo is a programme for a global navigation satellite system and it is currently being built by the all European Union countries and the European Space Agency (ESA). Recognizing the importance of satellite navigation, positioning, and timing in different fields, a civilian European system was conceived and developed in the early 1990s. It started with the European contribution to the first generation of GNSS (GNSS-1), the EGNOS program, and continues with the generation of GNSS-2, the Galileo program. The goal is for it to be completely functional by 2020 and will provide coverage to the Polar Regions. When developed, the Galileo system will consist of 30 satellites (27 operational + 3 active spares), positioned in three circular medium Earth orbit (MEO) planes inclined at 56 degrees to the equatorial planes at an elevation of 23,222 km altitude above the Earth and an orbital period of 14 hours and 5 minutes.

### 5. BeiDou-COMPASS system

The BeiDou Satellite Navigation and Positioning System is being developed by China. This system was designed to provide positioning, fleet-management, and precision-time dissemination to Chinese military and civil users. At present, it has 10 satellites and covers the Asia-Pacific region. Unlike other GNSS, which use MEO (altitudes between 19,000-23,000 km), BeiDou located its satellites in geostationary orbit, approximately 36,000 km above sea level in the plane of equator. However, the Beidou system is being currently upgraded under the name COMPASS to achieve full GNSS capability by 2020. When completed this system is expected to have 35 satellites in 21, 150 km orbits inclined at 55.5 degrees to the equatorial plane and an orbital period of 12 hr and 36 min.

In addition to the above systems that either have or expected to have GNSS capability, two other regional systems also provide position measurement over a limited region. Indian Regional Navigational Satellite System (IRNSS) is planned to have seven geostationary (GEO) satellites and is expected to provide 20 m accuracy within India and 2000 km of its neighbourhood. The Japanese Quasi-Zenith Satellite System (QZSS) is primarily a communication system with navigational capability. It consists of three highly inclined, geosynchronous satellites. At least one satellite is over Japan at all times.

In the future the combined use of the GNSS systems will increase the overall performance, robustness of satellite navigation for the benefit of all potential users.

## 6. GPS signal and structure

As mentioned earlier, GPS signal consist of two carrier waves ( $L_1 = 1575.42$  MHz or 19 cm and  $L_2 = 1227.60$  MHz or 24.4 cm), two or more digital codes (Coarse Acquisition code or C/A on  $L_1$  and P-code on both  $L_1$  and  $L_2$ ), and a navigation message. Civilians have access to C/A code on  $L_1$  only. P-code is encrypted with an unknown W-code resulting in a Y-code [i.e., P (Y)] and is not available to civilians (for military purpose only). This is called antispoofing. Use of P-code can provide very accurate estimation of position (precise positioning service, PPS) as ionospheric distortion can be completely eliminated using  $L_1$  and  $L_2$  signals. However, use of C/A code only cannot provide very accurate estimation of position (standard positioning service, SPS). The newer satellites transmit two additional codes ( $L_2$  CM – civilian moderate and  $L_2$  CL –civilian long). These additional codes will be helpful in minimizing errors due to atmospheric effects. The navigational message contains information about almanac, ephemeris, clock correction, satellite health, atmospheric correction etc. This is added to both C/A and P-Code. These codes contain information about the satellite identity (PRN) and timing information. These codes are then added on to  $L_1$  (both C/A and P codes) and  $L_2$  (P-code only). Figure 2 is a schematic diagram of the GPS signal.

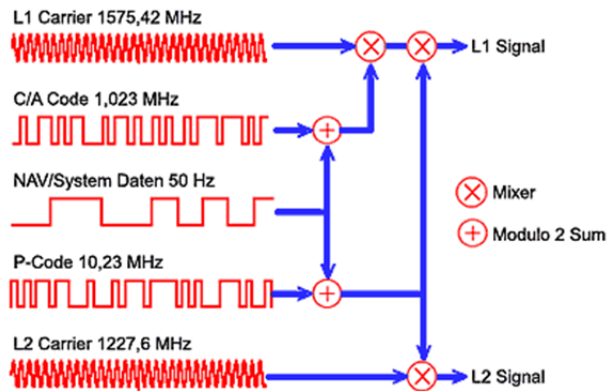

**Figure 2.** Composition of the signals from GPS satellites (Source: <http://www.kowoma.de/en/gps/signals.htm>)

## 7. GPS positioning principle

Resection is the principle used for locating the position of an object on the surface of the earth. Figure 3a shows that location A of an object on the surface of the earth can be easily determined if travel times of signals from two satellites to a receiver located at position A

are measured. Travel times can be multiplied by the speed of electromagnetic wave (speed of light = 299,729,458 m/s) to determine the distances between the satellites and the receiver. Resection principle can then be used to locate the receiver position A (i.e., point of intersection of two circles drawn with satellites as the center of the circle and respective distances to point A as radii – basically triangulation). Note that the other point of intersection of these circles is an unacceptable solution (why?).

Since the distances involved are never really measured, but are estimated from the times required for the signal to travel from satellites to the object, the process is called pseudorangeing. Note that any small error in time measurement may lead to relatively large error in position estimation as speed of light is very high. As indicated in figure 3b, any error in time measurements can locate the receiver at position B rather than the real location A and we would have no estimation of the magnitude of this error. However, if the timing signal is measured from a third satellite, a curved triangular region (B-B-B) can be determined within which the receiver should be located as shown in figure 3c. Thus it is critical to get signals from at least three satellites to get an estimate of position location and relative accuracy of that measurement. Since all GPS position measurements are performed in 3-D, signals from at least four satellites are needed to obtain the position fix (latitude, longitude, and altitude) and a measure of relative accuracy of that measurement.

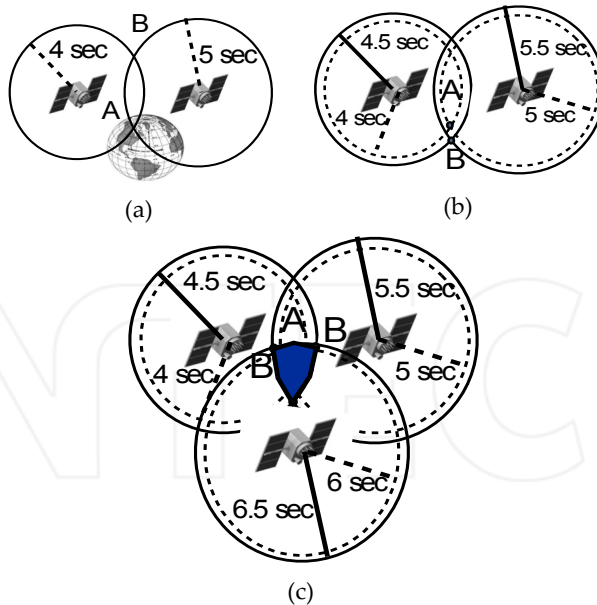

**Figure 3.** Determination of 2-D position of object A using pseudorangeing principle – (a) no error in time measurement, (b) effect of error in measuring time, and (3) region of uncertainty (or estimate of error) when timing signals from three satellites are utilized for determining position in 2-D.

Thus, if  $(x_0, y_0, z_0)$  are the unknown Cartesian coordinates of the receiver and  $(x_i, y_i, z_i)$  are the respective coordinates of the  $i^{\text{th}}$  satellite, the distance of the receiver from the satellite,  $d_i$ , can be obtained by:

$$d_i^2 = [c(t_i - e_t)]^2 = (x_i - x_0)^2 + (y_i - y_0)^2 + (z_i - z_0)^2 \quad (1)$$

where  $c$  is the speed of light and  $e_t$  is error in measuring time. If time measurements are available from four different satellites ( $i=1,2,3,4$ ), then we can write four nonlinear algebraic equations in four unknowns ( $x_0, y_0, z_0$ , and  $e_t$ ) that can be solved. Note that positions of satellites are known because each satellite transmits ephemeris as a part of the navigation message. If time measurements from more than four satellites are available, least square minimization is used to obtain the best estimation of the receiver location and associated measurement error.

## 8. Carrier phase measurement

An alternate way to measure the location of a receiver is to measure phase angle of the signal received by the GPS receiver. As shown in figure 4, a signal from the satellite will complete an integer number of cycles (say,  $N$ ) and a portion of the waveform as it arrives at the receiver. The receiver measures only the partial waveform or phase of the signal. It does not have any idea of the integer number of cycles between itself and the satellite. This is known as integer ambiguity. If the receiver tracks the satellite over time, it is possible to keep track of the phase change from the start. This information along with an optimization procedure can be used to solve for the unknown integer  $N$ . This is called ambiguity resolution. Since a fraction of the waveform or phase angle can be measured and wavelength of  $L_1$  carrier wave is 19 cm, this technique can provide millimeter precision compared with a few meters for C/A code measurements. To achieve this level of accuracy a local base station or a virtual base station is necessary to provide an accurate reference. This system is often referred to as real-time kinematic GPS or RTK GPS.

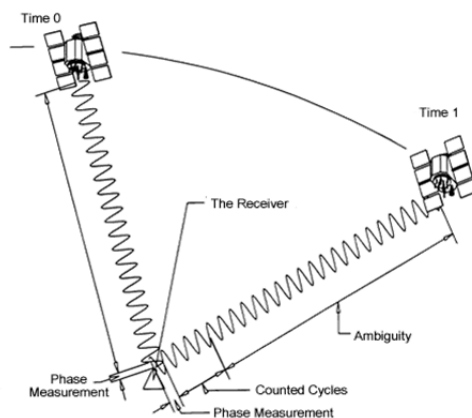
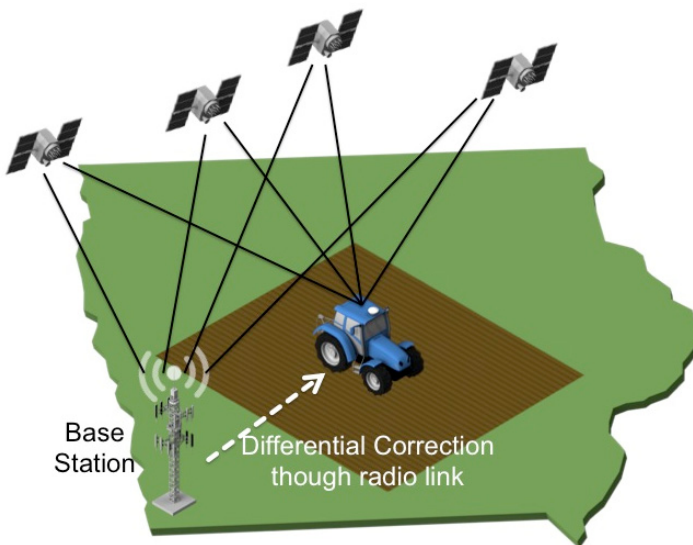

**Figure 4.** Principle of carrier phase measurement (Source: <http://nptel.iitm.ac.in/courses>)



## 9. Real-time differential GPS correction

Very high GPS accuracy can be achieved using post processing. However, for real-time applications that require on-the-go corrections, a differential GPS (DGPS) is preferred. A straightforward manner of accomplishing this is to use two GPS receivers (a rover and a base) that track same satellites, so that many of the errors can be minimized and higher accuracy can be obtained in real-time. Figure 5 provides a schematic diagram of the principle involved in differential correction. Since the position of the base station is known accurately, the error in estimating the location of the base station using satellite signals can be determined. This correction information can be communicated to the field GPS receiver (i.e., the rover) by a radio link and this information can be used increase its accuracy. However, the deployment of two GPS receivers for agricultural applications could be expensive in many instances. An alternative, to reduce the cost without degrading the positional accuracy, is to use one of the available differential correction services. If the GPS users obtain one of this available services, only one receiver can be used as a rover and no base receiver would be required.



**Figure 5.** Schematic diagram of a differential correction technique (Courtesy of TRIMBLE)

Agricultural use of GPS has significantly expanded due to the increased availability of differential correction. Today there are various types of differential correction services that are readily available to the user. These are:

- DGPS radio beacons (e.g., US Coastguard DGPS beacons along major waterways): These services can provide sub-meter DGPS accuracy. Reliable coverage is available on land, sea and air. This service is free and available in more than 40 countries; however, the correction signals degrade as you move away from the beacon location.

- **Space-Based Augmentation System (SBAS):** It is satellite based system that provides regional correction signals (e.g., Wide Area Augmentation System (WAAS) within North America, European Geostationary Navigation Overlay Service (EGNOS) within Europe, Multi-Functional Satellite Augmentation System (MSAS) within Japan and Southeast Asia, and GPS and geo-augmented navigation (GAGAN) within India) over a wide-area (L-band DGPS) through the use of additional satellite-broadcast messages. All of these systems work similarly and are compatible with each other, however, the accuracies of these free satellite based systems vary. They consist of reference stations distributed over a wide area, master stations to process and upload data, and geostationary satellites to transmit the correction signals to users. The WAAS service within USA is fully operational for safety-critical operations such as aircraft navigation and is specified at 7 m accuracy. Agricultural users have found WAAS to be a reliable source of correction, with an accuracy of better than 3 m and a much better pass-to-pass accuracy [12]. The two major commercial L-band satellite based correction providers are Fugro (OmniSTAR service) and Deere (Starfire service). OmniSTAR provides almost complete worldwide coverage. The Starfire service is based on the NASA Jet Propulsion Laboratory correction system. Both of these commercial service providers have a high-accuracy service that uses dual-frequency receivers and antennas for performance in the decimeter range (100–300 mm). OmniStar and Starfire are subscription services.
- **Dedicate-use RTK base station and RTK networks:** Real-time kinematic (RTK) systems establish the most accurate solution for GNSS applications, producing typical errors of less than 2 cm. This level of precision is not needed for general site-specific farming, but it does permit treatment of specific small location such as a plant-specific operation and is essential for precision guidance [6,13], controlled traffic farming [7,8], mechanical intra-row weed control or thinning of crop plants [14]. In this method, a base station is located at a known point close to where the vehicle operates and communicates with the rover through a radio transmitter. Two disadvantages of RTK-GPS solutions are: (i) the requirement that a base station be located within 10 km at all times which limits its use when farms are large or spread out and (ii) high capital cost. An alternative to the local base station that is becoming increasingly popular is the Virtual Reference Station (VRS) that essentially creates a virtual reference point near the rover using a network of RTK base stations. The VRS service is available for a fee from vendors such as OmniSTAR.

## 10. Applications of GNSS in agriculture

Satellite-based localization solutions have become quite mature and the GNSS receivers have found numerous applications in agriculture. These receivers are a key part of the precision agriculture technologies as position information is a prerequisite for site-specific crop management. However, not all tasks that need to be performed in precision agriculture need the same level of positioning accuracies [6,12]. Some precision agriculture operations such as yield monitoring, soil sampling or variable rate applications, can be performed using submeter accuracy differential GPS (DGPS) as errors below 1 m are acceptable for

these applications. Other tasks like mechanical intra-row weed control, thinning of crop plants, precise planting or autonomous navigation within tight rows demand decimeter- or even centimeter- level accuracy. A solution to this demanding requirement can be found in real-time kinematic GPS (RTK-GPS) which was discussed earlier.

Despite the fact that there exist different global positioning satellite systems, GPS and GLONASS are the only two fully operational GNSS system today. As discussed before, these two systems are similar. However, North American GPS has been in continuous use since the middle of 1990s and many of the agricultural applications have been developed using this system. Applications of GPS for agricultural purposes have exploded in the recent years and the literature is rich with many very interesting examples. In the following discussion we limit our attention to six specific applications with which the authors are very closely involved:

- i. Yield monitoring
- ii. Compaction profile sensing
- iii. Tree planting site-specific fumigant application
- iv. RTK GPS based plant mapping
- v. Precise weed management system
- vi. Robotic applications

### **10.1. Yield monitors**

The ability to continuously monitor and map yield at harvest and observe its spatial variability is a key step in implementing site-specific crop management. Spatial variation in site-specific yield data within a field frequently reflects the variation in soil, plant, and environmental characteristics. Farmers, consultants and researchers have utilized yield monitors to map yield of many crops. However, majority of precision agriculture practice adoption has occurred in grains, oilseeds and cotton. Generally speaking, cereal grain combines use physical sensors to measure grain flow (i.e. impact sensor), whereas cotton yield monitors use microwave or near-infrared sensors to measure amount of cotton. GPS device is a key part of the yield monitor as position data is critical to determine spatial variability in crop yield. Other sensors such as forward speed sensor (i.e. radar, ultrasonic sensor or magnetic pickup on the transmission drive shaft), crop moisture sensor and header height sensor are also mounted on the combine. With all of these sensors and instrumentations, it is possible to map spatial variability in yield data and create yield maps and track field performance from year to year. These maps are very useful to create different management zones for various inputs within a field.

The yield monitor shown in figure 5 was used in a study conducted at University of Cordoba, Spain. The yield monitor (model PF3000, AgLeader Technology Inc.) was mounted on a four-row cotton harvester (model 9965, Deere & Company Ltd.) and calibrated. It consists of four optical cotton flow sensors located in the ducts and a GPS receiver (Trimble model AgGPS 132) with Onmistar differential corrections [15]. The goal of

this study was to investigate the relationship between yield variability and spatial variability of some soil properties for 6 ha irrigated cotton field located in southern Spain. The soil samples were taken from the 0-20 cm depth in the Spring on a 20x20 m grid (133 samples). The soil was analyzed for a range of properties including texture (sand, silt and clay), organic matter (OM), phosphorus (P), potassium (K) [16]. Kriged maps of each soil property and crop yield were generated using Surfer software. The main cause of the spatial variability in cotton yield in this field was found to be due to the spatial variation in soil texture (in particular, the sand and clay percentages) as seen in figure 6. Soil texture variation influenced water content distribution and consequently the uniformity of plant stand [17].



**Figure 6.** Cotton yield monitor mounted and used at University of Cordoba, Spain. The combine is equipped with 4 optical flow sensors, a DGPS receiver and a display.

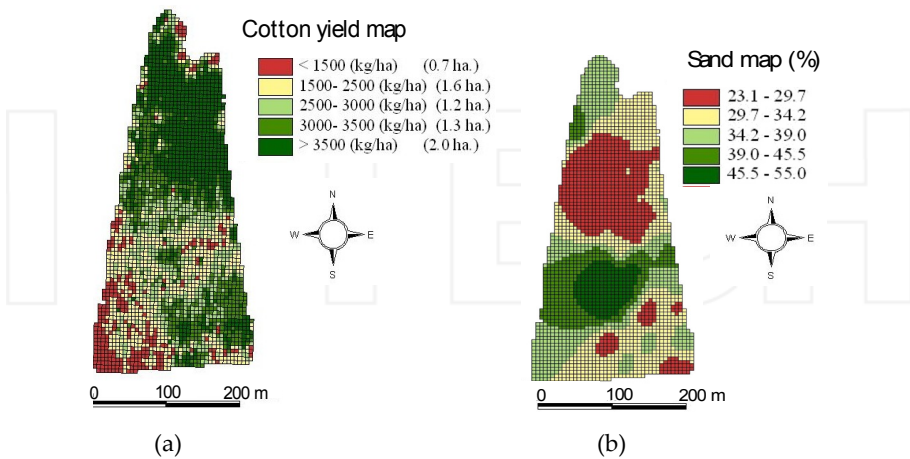

**Figure 7.** Kriged maps of: (a) cotton yield and (b) sand content in the test field located in southern Spain.

## 10.2. Compaction profile sensor

Soil properties and environmental conditions are generally regarded as the main causes contributing to variability in crop yield within a field. The research conducted at the University of California Davis in a processing tomato field has indicated that variability in water infiltration rate caused by variability in soil compaction is a major factor affecting processing tomato yield (Figure 8). Soil compaction is often measured using an ASABE (American Society of Agricultural and Biological Engineers) standard cone penetrometer (force per unit area of a penetrating standard cone known as cone index). However, cone index (CI) is a point measurement that exhibits high variability, and is labour intensive and time consuming to measure if a huge amount of data needs to be obtained to map a large field. To overcome these limitations a compaction profile sensor shown in figure 9 was developed. The device consists of five 5.1 cm long, active cutting elements that are directly connected to five octagonal load cells and can measure cutting resistance of soil directly ahead of the cutting elements. These active cutting elements are isolated from each other by 2.5 cm long dummy elements. Moreover, a dummy element of length 8 cm was attached above the topmost active element. This long dummy element was included since an earlier study had indicated that the soil cutting data from the top layer was unreliable due to depth fluctuations and potentially a different mechanism of soil failure (i.e., crescent versus lateral soil failure). This device was capable of getting soil cutting resistance data over the depth profile of 7.5 to 45.7 cm below the surface. A sub-meter accuracy DGPS receiver that used coastguard beacon differential correction was included with this system to provide position information. In addition, a radar (model RADAR II, DICKEY-john Corporation, Illinois, USA), was employed to measure ground speed.

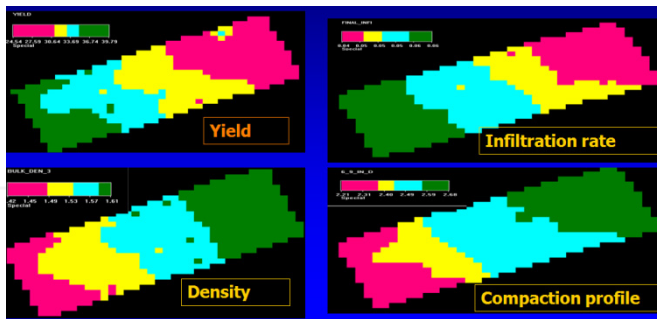
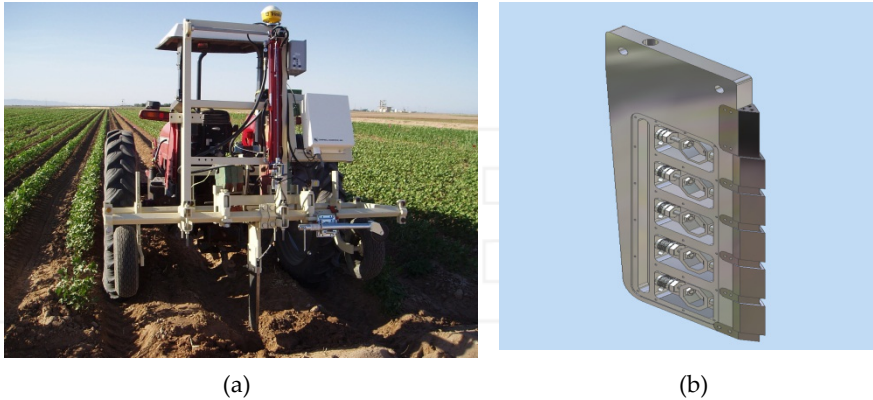

**Figure 8.** Spatial variability in crop yield, infiltration rate, bulk density of soil, and soil compaction level for a section of a processing tomato field located in Winters, CA, USA.

The compaction profile sensor was calibrated and then tested in agricultural fields in California and in the Midwest. ASABE standard cone penetrometer was also tested in the same fields. The force acting on the unit area of the cutting element, termed CIE (cone index equivalent), was related to CI values at the same depth and depth of operation of the cutting element. Figure 9 shows the plot of the measured CIE values versus the predicted CIE values based on a multiple linear relationship given by the following equation:

$$CIE_i = 0.15CI_i + 2.244d_i + 0.69CI_i x d_i \quad (2)$$

where  $d_i$  is the depth of operation of the  $i^{\text{th}}$  cutting element ( $i=1, 2, \dots, 5$ ) and CIE and CI are the corresponding cone index equivalent and cone index values respectively.



**Figure 9.** The compaction profile sensor developed at UC Davis. The figure on the left (a) provides an overview of the system when it is mounted on a toolbar. The figure on the right (b) provides internal construction details of the sensing elements.

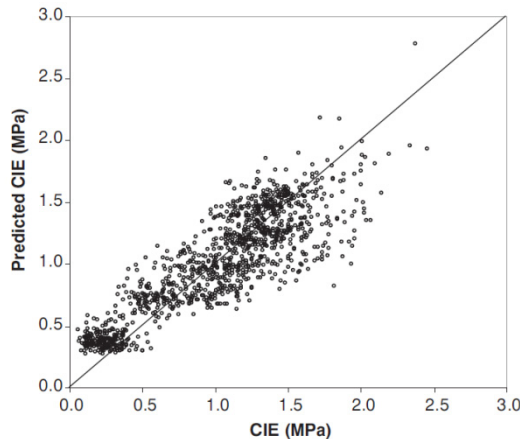

**Figure 10.** Comparison between predicted CIE (cone index equivalent) values and measured CIE values obtained during the field tests in the Midwestern United States [Source: Andrade-Sanchez et al. (2008)].

The map of the soil compaction level estimated from the force on the cutting element located between 15 to 22.5 cm deep layer of soil is shown in the lower right hand side of figure 8. The soil compaction map for this layer correlated very well with the yield map (upper left hand side). Complete description of the compaction profile sensor and its application for mapping soil compaction profile can be found in Andrade-Sanchez et al. (2008).

### 10.3. Tree planting site-specific fumigant application

A major concern when one replaces an old orchard with a new one is the incidence of replant disease. For example, when young almond trees are planted at sites from where the old almond or stone fruit trees have been removed, the new plants get stunted or even get killed due to a poorly defined soil borne disease complex called replant disease. Although the exact cause of this disease is not well-understood, pre-plant, site-specific application of small amount of fumigant such as methyl bromide (MB), chloropicrin (CP), 1,3-Dichloropropane (1,3-D), or two-way mixtures of CP with MB or (1,3-D) can control the incidence of replant disease. Therefore, it is a common practice to apply fumigants to the soil over 2-4 m wide continuous strips centered over the future tree rows.

However, the researchers at USDA/UC Davis have found that application of a small amount (0.2 kg/site) of fumigant in the vicinity of future tree planting sites can control replant disease effectively. While continuous application requires about 168 kg/ha of fumigant, tree planting site-specific application requires only about 40 to 70 kg/ha of the fumigant based on the tree spacing along the row. This is a 58 to 76% reduction of chemical load on the environment and cost. Therefore tree planting site-specific application of fumigants is not only economical, but also beneficial to the environment.

However, manual tree planting-site-specific fumigant application is very labor intensive and handling of fumigants poses some risk. Accurately locating tree-planting site is a time consuming process. However, with the advent of high performance GPS (HPGPS), computer technology can be used to apply the right amount of fumigants at the right location. This type of GPS system has an accuracy of about 20 cm rather than the coastguard beacon based DGPS that has sub-meter accuracy. This higher accuracy is necessary to turn on and off the fumigant applicators over a two meter long strip at the center of which a tree would be planted (Note that a sub-meter accuracy DGPS system may introduce very large error in the treatment zone).

A shank type fumigant applicator on loan from TriCal Inc. (figure 11a) was retrofitted with a precision fumigant applicator (PFC). This unit communicated with a rate controller to obtain the actual application rate. PFC was uploaded with a tree-planting grid (tree map) developed using a specially writing software. The inputs to the software consisted of HPGPS coordinates of the four corners of the orchard, row spacing, tree spacing along the row, fumigant application zone length, and pattern of planting (i.e., rectangular versus diamond shape). The PFC receives the location information from the HPGPS receiver and information from an inclination sensor located near the solenoid valve (to determine if the shanks are in raised or lowered position). The PFC would turn on a solenoid valve and apply fumigants, if the HPGPS unit located the shank within the treatment zone and the shanks were lowered into the ground. If the applicator was in the raised position or if the shanks were outside the treatment zone, PFC would close the solenoid valve. The system was calibrated using road and field tests and was found to work well (less than 15 cm error in applying the fumigant in the treatment zone if appropriate look ahead value was used).

The system has been used to treat tree-planting sites in several orchards over the past five years.

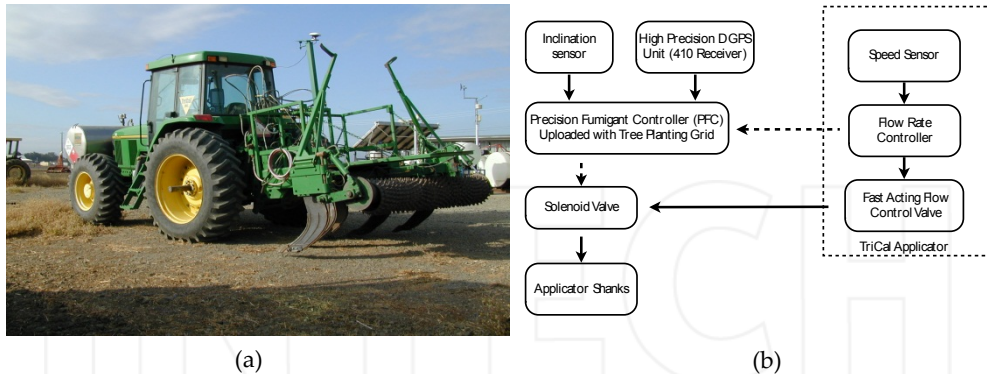

**Figure 11.** A shank type fumigant applicator (a) retrofitted with a precision fumigant controller and a HPGPS positioning unit, (b) Schematic of the fine-tuned site-specific fumigant application system.

#### 10.4. RTK-GPS based plant mapping

In recent years, application of centimeter accuracy RTK-GPS has received a lot of attention because of its ability to provide extremely precise location information. These highly precise RTK-GPS based systems, such as automated tractor steering systems, have become very popular in recent years. Figure 12a shows an auto guidance tractor equipped with RTK-GPS forming the bed to plant processing tomatoes. Figure 12b shows the same tractor being used to install drip tape about 12.5 cm away from the plant line and 12.5 cm below the soil surface, while figure 12c shows planting processing transplants along the centerline of the bed. Figure 12d shows mechanical cultivation using cultivator tines spaced about 5 cm away from the plant line, while figure 12e shows the resultant cultivated field. Figure 12f shows a deep cultivation operation in the same field along the centerline of the bed after the tomato crop was removed. Although these auto guidance systems use cm accuracy RTK-GPS system, the overall pass-to-pass accuracy of the tractor is expected to be about 2.5 cm. What is very interesting is that when the cultivator blades were placed 5 cm away from the plant line and the auto guidance tractor was operated at 11 km/h, vary little plant damage occurred. Moreover, when deep cultivation was done along the centerline of the bed following tomato harvest, no damage occurred to buried drip tape placed 12.5 cm away from the plant line [18].

While RTK GPS based autoguidance tractors have become a commercial reality, extremely interesting additional applications exist for this type of system in production agriculture. One such possibility is the ability to create a plant map using RTK GPS by monitoring the seeds or transplants while they are being planted. The availability of precision mapping technologies for crop plants enables a new opportunity for plant specific treatment systems where the resources for plant care are tailored to the needs of individual plants rather than



providing the same level of resources to all plants in the field irrespective of the need or potential for utilization [19,20].



**Figure 12.** RTK GPS based autoguidance system used for various cultural operations – (a) bedding, (b) drip tape installation setup, (c) transplanting processing tomatoes, (d) cultivation, (e) plants following cultivation, and (f) deep tillage after plant removal.

One such possibility is the ability to create a plant map using RTK-GPS by monitoring the seeds or transplants while they are being planted. Such a plant map can then be utilized for subsequent intra-row, weed-specific cultivation or chemical application. Figure 13 shows a 4-row, Salvo 650 vacuum planter retrofitted with a RTK-GPS unit developed by [13]. The system consists of two microcomputers one of which monitors the seeds using optical sensors (four sensors - one per row) as they are being planted and records the event along with the time (i.e., row number in which the seed was seen and the time at which the event occurred). Moreover, it obtains the RTK-GPS coordinates and records them along with the time tag. The second microcomputer monitors the first microcomputer and displays the planter performance information on a monitor mounted in the cab. The time tag allows to determine the exact location where a given seed was dropped into the ground facilitating the creation of a seed planting map. The actual plant map is expected to be slightly different due to system dynamics. The study conducted at UC Davis has shown that the difference between RTK-GPS based expected seed location versus actual plant position in the field was in the range of 3.0 to 3.8 cm.



**Figure 13.** A RTK GPS based seed monitoring system retrofitted onto a 4-row, Salvo 650 vacuum planter

However, the Ehsani's system utilized an additional RTK-GPS system dedicated to the planter, in addition to any RTK-GPS auto guidance systems present on the tractor, greatly increasing the capital cost of the crop mapping operation. Perez-Ruiz et al. (2012) [14] developed a centimeter-level accuracy plant mapping system for transplanted row crop which utilized a single RTK-GPS auto guidance system mounted on the tractor, and not the planter, thereby reducing the capital cost of the system (A similar approach was investigated by Mr. Mark Mattson, a Graduate Student Researcher working under Dr. Upadhyaya's guidance at UC Davis in 2002). They developed an instrumented hitch orientation sensor that allowed for accurate real-time monitoring of the position of the transplanting sled in relationship to the tractor. When combined with tractor mounted RTK GPS coordinate data, a transplant map could be created by sensing transplant placement

during planting. Field tests using this system showed that the mean RMS accuracy of the system was 2.67 cm in the along-track direction where 95% of the crop plants were located within a circular radius of 5.58 cm from the mapped location. These results showed that it was possible to use a single RTK-GPS system mounted on the tractor for GPS location mapping of planting events occurring on the tractor-drawn transplanter without the need for an independent RTK-GPS system located on the transplanter or planter. Figure 12 shows the crop plant locations determined by the automatic GPS mapping transplanter during planting (orange triangle). The inset photo shows the manual RTK-GPS survey measurement of the plant location obtained during ground truthing. The ground truth points (black circles) were overlaid on the automatically generated map for comparison.

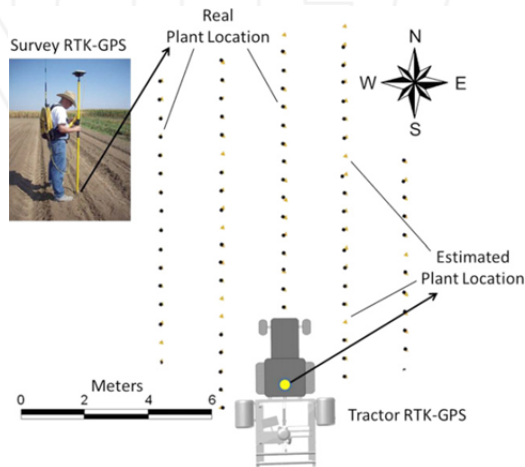

**Figure 14.** Automatically generated crop geosition map

### 10.5. Precision weed management system

Improved mechanical methods of weed control have been motivated by an increased consumer demand for organic produce, consumer and regulatory demands for a reduction in environmentally harmful herbicide use, and a decrease in the availability of farm workers willing to perform manual agricultural tasks such as hand weeding. Extensive research has been conducted to address this issue and alternate techniques have been developed to control weeds in the plant line [21-23].

Since the RTK GPS based seed or transplant map was close to the actual plant map, it was hypothesized that a simple greenness sensor could be used to look for plants and when a plant is detected its coordinates could be compared with the coordinates of plants in the plant map. If there is no corresponding plant on the plant map, then it can be assumed to be a weed and an appropriate herbicide could be applied kill the weed. Such weed-specific chemical application can reduce the amount of chemical by 24-51% thus reducing cost and protecting the environment from the harmful effect of the chemical. Employing this principle, we designed and built, at University of Sevilla, a fully automatic electro-hydraulic

side-shift frame for row center positioning controlled by RTK GPS location information to perform a precise mechanical (between row) and narrow herbicide band spray (over the crop row) weed control. Figure 15 shows the frame, placed between the tractor and implement, that allowed centering the narrow band treatments (10 cm) of herbicide above the rows and parallel to the crop rows with a minimum lateral drift (cross track error).

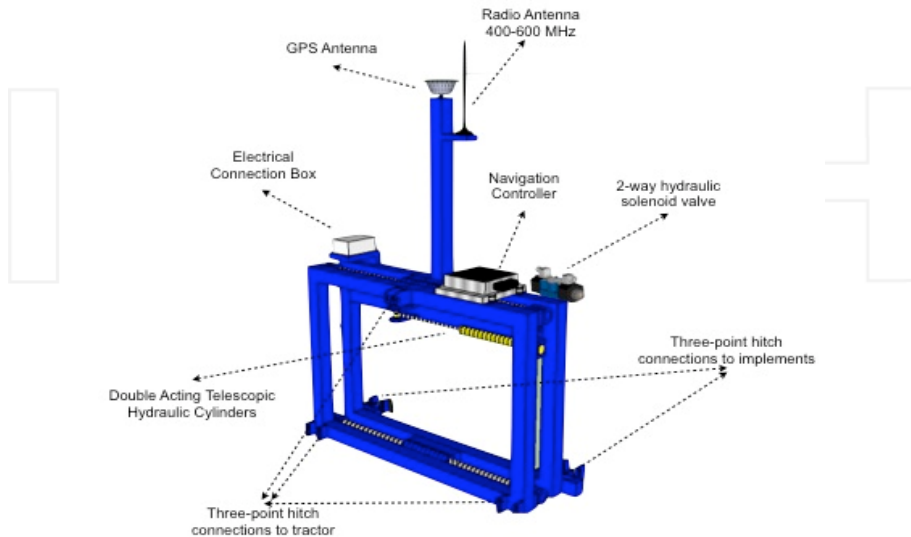

**Figure 15.** Schematic diagram showing the side-shift frame system developed for row position centering controlled with a RTK-GPS geopositioning system.

This new system, equipped with RTK GPS technology, was used for targeted herbicide application to weeds along crop rows, without reducing the efficacy of the intra-row chemical control treatment, while providing savings of approximately 50% of herbicide. The savings in applied chemical not only reduced production costs but also reduced the environmental impact caused by the chemical. Moreover, use of this system led to reduction of labor required to hand weed on the average from 15.3 hours per hectare for the conventional treatment and 13.2 hours for the improved plant/weed specific treatment. Complete elimination of herbicide application while achieving a high percentage of elimination weeds is a very attractive proposition and is critical for organic growers to reduce production cost. However, it is a very challenging task. An interesting approach is to use plant-specific mechanical cultivation based on a RTK-GPS based plant map. Dr. Slauhgter and his research group at the department of Biological and Agricultural Engineering (UC Davis) have developed an automatic intra-row, automatic weeding system using cultivator knives that remove the weeds along the plant lines of transplanted processing tomato crop using RTK-GPS based plant map obtained during transplanting operation. Field test results indicated that this RTK-GPS based automatic weeding system did not damage any plants while performing intra-row cultivation at travel speeds of 0.8 and 1.6 km/h. Additional information of automatic intra-row weeding system can be found in [14].



**Figure 16.** A RTK-GPS based robotic cultivation system-(a) A cultivator retrofitted with a RTK-GPS system in operation, and (b) The cultivating tines open to protect the plant based on the plant map and closed to get rid of weeds in between plants in the crop row.

### 10.6. Intelligent system applications

The introduction of semiautomatic systems in combine harvesters a few decades back was one of the first steps towards automation. Today, full automatic, robotic systems have been incorporated into many different agricultural operations - from harvesting to intelligent application of herbicides. These new systems in the agricultural sector present new challenges such as safety, user education and training, and machine actuation. Of these, safety is the most important as actuation often requires sensory information before mechanical execution. Robotic systems require sophisticated hardware and software in order to allow the adaptation to changing environments and accomplish exigent missions in a safe and efficient way. Two different approaches have become essential characteristic of intelligent vehicles system: combining local information with global localization to enhance autonomous navigation, and integrating inertial systems with GNSS for vehicle automation [24].

Many researchers have spent a significant amount of effort in recent years to solve pressing and challenging problems facing agriculture today. For instance, the DEMETER Project (USA, Carnegie Mellon University, 2000) has led to the development of a new generation self-propelled hay harvester for agricultural operation. The goal was to provide a "Program-Execute" so that an expert harvester operator merely has to harvest a given field once ("programming the field") allowing a less-skilled operator play back the programmed field ("executing the field") at a later date. A major disadvantage of this approach from the point of view of safety was the potential loss of large and heavy machines in the field leading to very dangerous situations. This could be avoided by using a fleet of small machines that are deployed simultaneously and less dangerous to the people and the surrounding while being equally effective in completing the operation.

There have been some attempts to configure colonies of robots that could be used for agricultural activities, such as the project entitled "Cognitive Colonies" (USA, Carnegie Mellon University, 2001). This project consists of ten small robots constituting a "model" facility. These robots will form a colony whose sole purpose is the generation of a map of

this area. After an initial period during which basic distributed mapping operation is created, the sponsors will be asked to "disable" robots of their choice and observe the reaction of the colony to this loss. The results of this project can be applied to configure groups of robots that work collaboratively in accomplishing a task changing the configuration depending on the number of operative robots.

In the past couple of decades, precision agriculture has emerged as a promising field to increase crop productivity. For instance, the Robotic Weeding Project under development at the Department of Agricultural Engineering, University of Aarhus, Denmark, is devoted to building an autonomous vehicle with a vision system capable of controlling a grid-dosing sprayer system. Likewise, the project "Autonomous Agricultural Spraying" (USA, Carnegie Mellon University, 2007) devoted to make agricultural spraying significantly cheaper, safer and more environmentally friendly through automation, such that a single operator, from a remote location, can oversee the nighttime operation of at least four spraying vehicles.

In the last two years, projects such as RHEA (Robot Fleets for Highly Effective Agriculture and Forestry Management) have emerged to develop a fleet of heterogeneous –land and aerial-robots to carry surveillance and actuation system over the mission field. The land units will be based on medium-sized autonomous vehicle with onboard equipment for navigation and application of treatments. Thanks to the integration of GNSS and sensors each robot controller can receive its desired trajectories from the mission planner and its current position from its own geographical positioning system. Every robot controller can compute its own control signals for traction and steering in order to track the desired trajectory avoiding obstacles – trees, bushes, rocks, holes, protrusions, animals, humans, etc.- in the path.

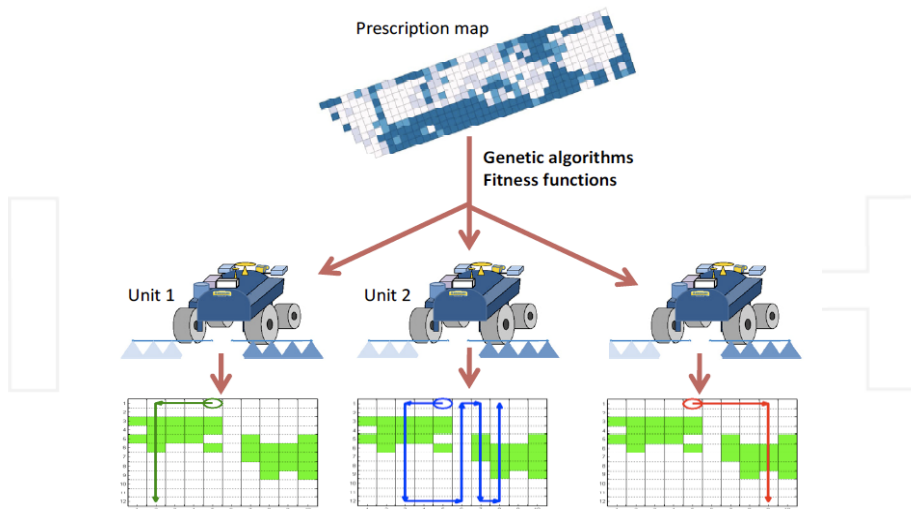

**Figure 17.** Distribution of three ground units to conduct a spraying operation following a predefined prescription map. Path plan for each individual unit marked with a different color. Green cells indicate the presence of weeds. Circles indicate the starting position

## 11. Conclusion and outlook

The future applications of GNSS in precision agriculture operations know no bounds. This type of agriculture, where the positioning along with additional data on the vehicle status, soil properties, crop health, and fertilizer requirements provide the knowledge base for decision making and management to improve productivity, safety, and quality while reducing cost and environmental impact. The central concept of precision agriculture is to apply only the inputs - what you need where you need and when you need - and this can only be done if large amount of geo-referenced data are available to make informed management decisions.

Agricultural applications such as yield monitoring, variable rate application, plant mapping, precise weed management, etc. require many sensors to acquire data from the field, but these data can only be linked together through a map by means of the location information provided by the GPS or any other GNSS receiver. With this type of precision agriculture data, the prescriptions maps can be created for planning future farming tasks.

One benefit of GNSS receivers over GPS-only is the increased number of satellite available for location calculations by the receiver. This is possible because GNSS-compatible equipment can use navigation satellites from other networks outside the GPS system. In addition, reliability is increased in areas where GPS receivers cannot operate or provide poor accuracy. The higher end GNSS receivers can currently observe up to around 72 satellites and are capable of accommodating additional satellites as more satellite-based systems become operational. More benefits of GNSS receiver include; 1) A shorter warm-up time (known as “time to first fix”); 2) Reduced delay in recomputing a position if satellite signals are temporarily blocked by obstructions (reacquisition time); 3) The ability to compute a position where is difficult for a GPS receiver operation, specially near tree rows, building, big obstacles, etc. In order to clarify and avoid confusion among agricultural users it would be worthwhile to remember that by design the GNSS receivers are compatible with GPS; however, GPS receivers are not necessarily compatible with GNSS.

Currently, the scientific community is devoting great efforts to avoid the GNSS signal interruption caused by shading of the GNSS antenna by terrain or obstacles (e.g. trees, buildings, implements, etc.) or by interference from an external source to improve the accuracy of agricultural applications. The need to provide continuous location data or navigation during periods when the GNSS signal is interrupted is the impetus for integrating GNSS with various additional sensors (e.g. inertial sensor, dopplerometers, altimeters, odometers, etc.). The integration of GNSS products and services with sensors will expand the possibilities of agricultural use of this technology in the future even further.

### Author details

Manuel Perez-Ruiz

*Aerospace Engineering and Fluids Mechanics Department, University of Sevilla, Spain*

Shrini K. Upadhyaya

*Biological and Agricultural Engineering Department, University of California, Davis, USA*

## Acknowledgement

This work was partially financed by the European Union's Seventh Framework Programme [FP7/2007-2013] under Grant Agreement number 245986. The authors thank professor David Slaughter, Biological and Agricultural Engineering Department, UC Davis for his valuable suggestions during the writing process of this chapter.

## 12. References

- [1] Griepentrog, H.W., Blackmore, B.S., Vougioukas, S. (2006). Positioning and navigation (Chapter 4.2). In A. Munack (Ed), CIGR handbook of agricultural engineering: Volume VI-information technology (pp. 195-204). St. Joseph, MI 49085, USA: ASABE.
- [2] Bauer, W.D., Schefcik, M. (1994). Using differential GPS to improve crop yields. *GPS World*, 5(2), 38-41.
- [3] Petersen, C. (1991). Precision GPS navigation for improving agricultural productivity. *GPS World*, 2(1), 38-44.
- [4] Wilson, J.N. (2000). Guidance of agricultural vehicles-a historical perspective. *Computers and Electronics in Agriculture*, 25, 3-9.
- [5] Pérez-Ruiz, M., Carballido, J., Agüera, J., Gil, J.A. (2011). Assessing GNSS correction signals for assisted guidance systems in agricultural vehicles. *Precision Agriculture*, 12, 639-652.
- [6] Larsen, W.E., Nielsen, G.A., Tyler, D.A. (1994). Precision navigation with GPS. *Computers and Electronics in Agriculture*, 11, 85-95.
- [7] Chamen, W.C.T., Watts, C.W., Leede, P.R., Longstaff, D.J. (1992). Assessment of a wide span vehicle (gantry), and soil and crop responses to its use in a zero traffic regime. *Soil and Tillage Research*, 24, 359-380.
- [8] Chamen, W.C.T., Dowler, D., Leede, P.R., Longstaff, D.J. (1994). Design, operation and performance of a gantry system: experience in arable cropping. *Journal of Agricultural Engineering Research*, 59,45-60.
- [9] Grewal, M.S., Weill, L.R., Andrews, A.P. (2011). *Global Positioning Systems, Inertial Navigation, and Integration*. Wiley, ISBN 0471-35032-X, New York.
- [10] El-Rabbany, A. (2006). *Introduction to GPS- The Global Positioning System*. Second Edition. Artech House, Boston, 210 p.
- [11] Misra, P., Enge, P. (2006). *Global Positioning System: Signals, Measurements, and Performance*, 2<sup>nd</sup> ed., Gamba-Jamuna Press, ISBN 0-9709544-1-7, Lincoln, MA.
- [12] Heraud, J.A., Lange, A.F. (2009). Agricultural automatic vehicle guidance from horses to GPS: How we got here, and where we are going. ASABE Distinguished Lecture Series No. 33. ASABE, St. Joseph, MI 49085, USA.
- [13] Ehsani, M.R., Upadhyaya, S.K. Mattson, M.L. (2004). Seed location mapping using RTK-GPS. *Transactions of the ASABE*, 47, 909-914.
- [14] Pérez-Ruiz, M., Slaughter, D.C., Gliever, C.J., Upadhyaya, S.K. (2012). Automatic GPS-based intra-row weed knife control system for transplanted row crops. *Computers and Electronics in Agriculture*, 80, 41-49.



- [15] Agüera, J., Pérez-Ruiz, M., Gil, J.A., Madueño, A., Zarco-Tejada, P., Blanco, G. (2003). Determining spatial variability of yield and reflectance of a cotton crop in the Guadalquivir Valley. In memory: 4<sup>th</sup> Conference on Precision Agriculture 347-348 pp.
- [16] Spark, D.L., Page, A.L. Helmke, P.A., Loccpert, R.M., Sottanpour, P.N., Tabatai, M.A., Johnston, C.I, Sumner, M.E. (1996). Methods of soils analysis, part 3<sup>rd</sup> ed. chemical methods, Agron. eds No. 5, 3 ed., American Society of Agronomy, Madison.
- [17] Bravo, C., Giráldez, J.V., Agüera, J., Pérez-Ruiz, M., González, P., Ordóñez, R., Gil, J.A. (2004). Assessing and modelling spatial variability of soil properties and association with the cotton yield map. Book of Abstracts. ISBN 90-76019-258. AgEng 2004, Leuven. pp. 916-917.
- [18] Abidine, A.Z., Heidman, B.C., Upadhyaya, S.K., Hills, D.J. (2004). Autoguidance system operated at high speed causes almost no tomato damage. California Agriculture, 58, 44-47.
- [19] Chancellor, W.J. (1981). Substituting information for energy in agriculture. Transactions of the ASAE, 24, 802-807.
- [20] Chancellor, W.J., Goronea, M.A. (1993). Effects of spatial variability of nitrogen, moisture, and weeds on the advantages of site-specific applications for wheat. Transactions of the ASAE, 37, 717-724.
- [21] Jørgensen, R.N. Sørensen, C.G., Maagaard, J., Havn, I., Jensen, J., Søgaard, H.T., Sørensen, L.B., 2007. HortiBot: A system design of a robotic tool carrier for high-tech plant nursing. Agricultural Engineering International: CIGR Ejournal Manuscript ATOE 07 006. Vol. IX: 13pp.
- [22] Nørremark, M., Griepentrog, H.W., Nielsen, J., Søgaard, H. T., 2008. The development and assessment of the accuracy of an autonomous GPS-based system for intra-row mechanical weed control in row crops. Biosyst. Eng. 101, 396-410.
- [23] Van Evert, F. K., Samson, J., Polder, G., Vijn, M., Van Dooren, H., Lamaker, A., Van Der Heijden, G. W. A. M., Van der Zalm, T., Lotz, L. A., 2011. A robot to detect and control broad-leaved dock (*Rumex obtusifolius* L.) in grassland. J. Field Robot. 28, 264-277.
- [24] Rovira, F., Zhang, Q., Hansen, A.C. (2010). Mechantronics and Intelligent Systems for Off-road Vehicles. London: Springer.