

Generation of HDL Models for Bio-Impedance Sensor Simulation based on Microelectrodes

Alberto YÚFERA, +Estefanía GALLEGO

Instituto de Microelectrónica de Sevilla (IMSE), Centro Nacional de Microelectrónica (CNM-CSIC)
Universidad de Sevilla, Av. Américo Vespucio s/n. 41092. Sevilla, Spain

+ Dto. Tecnología Electrónica, Universidad de Sevilla,
Av. Reina Mercedes, s/n. 41010. Sevilla, Spain

E-mail: yufera@imse-cnm.csic.es, estefania.gallego@gmail.com

Received: 22 October 2010 /Accepted: 11 January 2011 /Published: 8 February 2011

Abstract: This paper presents a computer tool for automatic analysis of cell culture images. The program allows the extraction of relevant information from biological images for pre and post system analysis. In particular, this tool is being used for electrical characterization of electrode-solution-cell systems in which bio-impedance is the main parameter to be known. The correct modeling of this kind of systems enables both electronic system characterization for circuit design specifications and data decoding from measurements. The developed program allows cell culture image processing for geographic information extraction and sensor sizing, generating cell count and Analog Hardware Description Language (AHDL) equivalent circuits useful for whole system simulations.
Copyright © 2011 IFSA.

Keywords: Microelectrode, Bioimpedance sensor, Analog Hardware Description Language (AHDL), Image processing.

1. Introduction

The impedance is a useful parameter for determining the properties of biological materials for several reasons: first, they are conductive [1], second, the impedance measurement represents a non-invasive technique, and third, it is a relatively cheap technique. Many biological parameters and processes can

be sensed and monitored using its impedance as marker [2-5]. Impedance Spectroscopy (IS) of cell cultures [6] and Electrical Impedance Tomography (EIT) in bodies [7] are examples of the impedance utility for measuring biological and medical processes and parameters. Classical real-time monitoring and imaging systems for biological samples are based on optical stimulation of samples, demanding bulky and expensive equipments. Embedded Complementary Metal-Oxide-Semiconductor (CMOS) sensors have been reported as an alternative for increasing the sensitivity to cell location and manipulation. The most popular are optical [10], capacitive [8] and impedance [9] based sensors. Despite of the high number of papers with optical sensors the last years, they still need external lamps, optical fibbers, etc., while capacitive and impedance based detection do not rely on peripheral equipment.

This paper is related to a new method for impedance measurement with applications to cell cultures. The system in Fig. 1 employs a two dimensional electrode array as sensors [11, 12] together with CMOS circuits for impedance measurements [13]. Microelectronic circuits must be designed to work with constraints imposed by the electrode sensors. The whole system in Fig. 1 can be fully-integrated in CMOS technologies [10, 14]. When low concentration cell cultures are carried out on top of the electrode array, depending on the position of each cell, specific electrode-cell impedance will be measured, allowing cell detection. Electrical models reported for the electrode-cell interface description [12,15] are the key for matching electrical simulations to real systems performance and hence decoding correctly the experimental results, usually known as a reconstruction problem. This kind of system can be used for real-time monitoring of cell cultures with the Electrical Cell Impedance Spectroscopy technique (ECIS), [6].

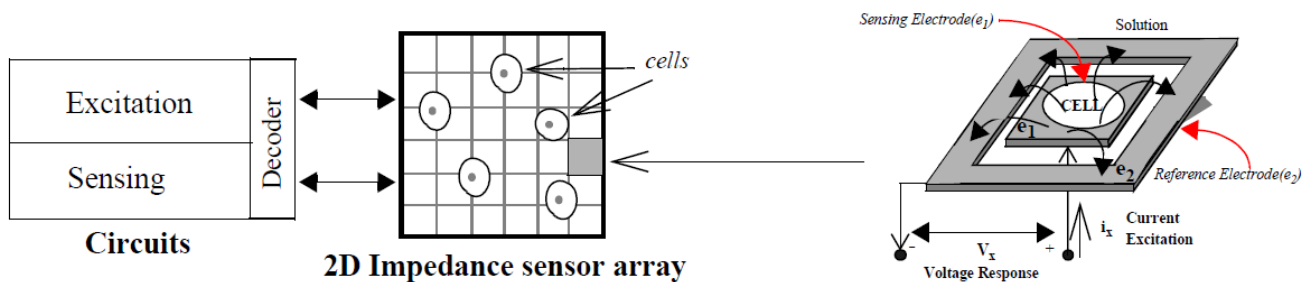

Fig. 1. Simplified system set-up: circuits and 2D electrode sensor array for bio-impedance measurements. Each sensor is has e_1 and e_2 electrodes. Cell culture is done on electrode top.

In this paper is presented a computer tool [17] that aids to cell culture image processing and reconstruction, helping to the optimization of circuit design since it enables the emulation of biological loads. In the system shown in Fig. 1, the tasks of to be done are:

- To perform a pre-processing of a cell culture image to define the areas occupied by cells. Main image processing is focused to segmentation for differentiating the total area covered by cells. It has been added a catalog of possible/typical cell culture images (five) to cover and wide range of applications.
- To incorporate the definition of the electrode area. This is important not only from the electrode-solution-cell system modeling and characterization point of view; but because the electrode sensitivity of the impedance sensor will be dependent of its size and working frequency. The electrode-cell overlap area will be considered as the main parameter of the electrode-cell system.
- To deliver information to the electronic system design, including data files and an electrical description of the full system (electrode-solution-cells) necessary to reproduce confident electrical

simulations. In our system, it is measured the covered area, position and cell number. The program generates files in Analog Hardware Description Language (AHDL), required in functional and electrical simulations (SpectreHDL [16]) for system design and validation.

The work is organized as follows: section 2 describes the program interface. Functions attached to the main menus are briefly detailed. Processing image algorithms are explained in section 3. Electrode definition in the program is analyzed in section 4, together with the employed model. In section 5, the measurements are scheduled and data can be extracted from images. Conclusions are highlighted in section 6.

2. The Interface

The main functions developed are described from its interface. Input images are loaded and displayed in a historical register on the left panel: the image panel area. At the center panel area, the processed image is displayed. There are four main action modules described in the following. The Processing panel includes functions and algorithms for image processing. Their objective is to separate the background area from the cells by using segmentation, filtering and morphological operations. This process can be done automatically or manually (by defining image processing functions and its parameters by the user). At the electrode panel two actions are performed. First, a tool for scaling definition of the image size allows expressing a non-dimensional image in microns units. Second, based on this scale, the electrode size is defined. The sensors are considered squared. The program will show the resulting array of sensors on the main panel. At the Measurement panel, the percent of cell coverage of each electrode can be obtained from the electrode-solution-cell overlapping area. This is the fill factor (ff) parameter. From the fill factor matrix, the parameterized electrical sensor (electrode) models are created using Analog Hardware Description Language (AHDL). At the Advanced processing panel, users can customize the segmentation process.

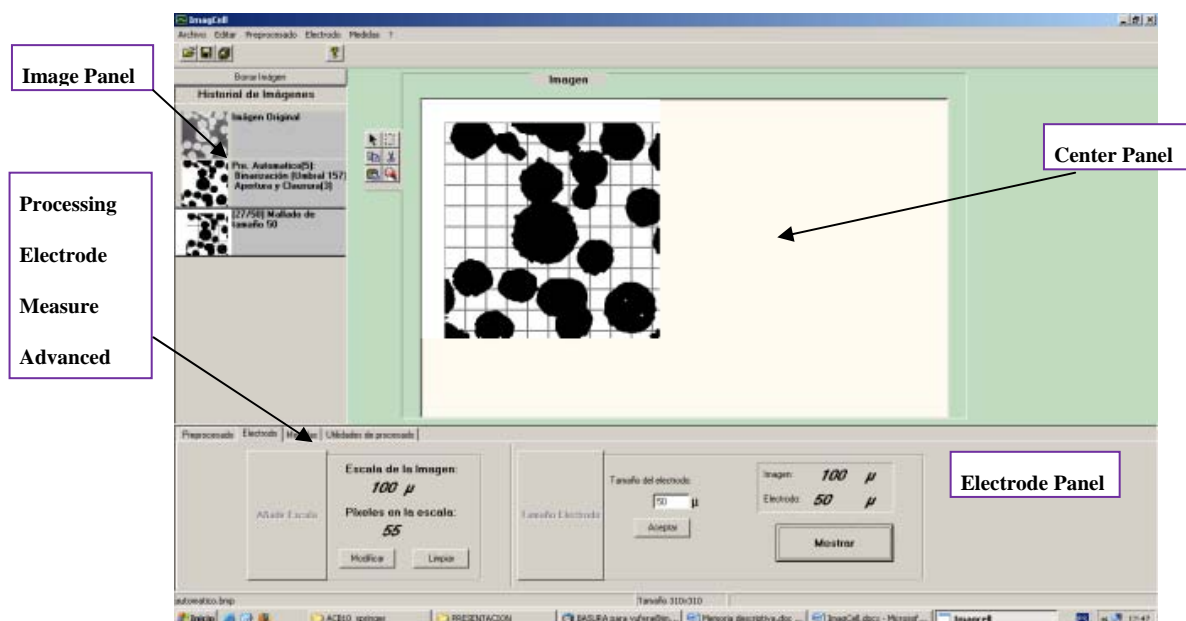

Fig. 2. ImagCell interface with: center panel, image panel, and the four functional panels: processing, electrode, measurements and advanced processing. The electrode panel is being displayed at the figure.

3. Image Processing

3.2. Image Format

The format chosen for input images is bitmap (.BMP). This is a digital representation for images in a matrix, in which each element has a number in a given range, depending on the image resolution. We have adopted 8 bits resolution (0 to 255). Digital image processing is done using black and white (B&W) colors. All the color images will be translated to B&W before to be processed.

3.2. Processing Approach

The main objective of the image processing [17] is to segment it, dividing into two disjointed areas: covered and non-covered (by cells). The proposed image processing is based on histogram information. This information is employed to define a threshold grey level. Fig. 3 shows this process. When a threshold level is set at histogram, for example, the 160 grey levels, the image is easily binarized into two parts: with (black) and without (white) cells. However, not all images are directly binarized easily and some kind of pre-processing should be done before.

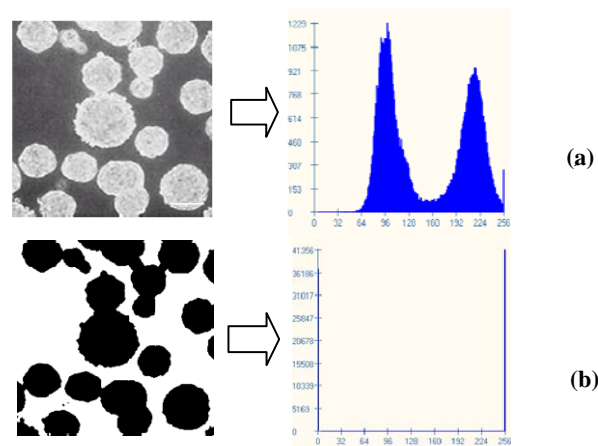

Fig. 3. (a) Original image and the corresponding histogram; (b) Image after binarization with the resulting histogram.

Two types of processing algorithms have been considered to image enhancement: Filter and Morphological algorithms. The main objective for both is to enhance the original images, eliminating noise sources, detecting closed areas, smoothing images, etc, before binarization. Both are based on convolution operations applied to basic templates (kernel) and the digital images. In the following, is related the set of algorithms employed.

3.2.1. Filter Algorithms

- **Median:** Calculates the element in the center place of an ordered list from minimum to maximum of the kernel value. Set the central pixel of the original matrix to this value.
- **Mean:** Calculates the mean of the kernel values. Set the central pixel of the original matrix to this value.
- **Maximum and minimum:** Calculate the maximum (minimum) of the kernel values. Set the central pixel of the original matrix to this value.

- **Sobel:** is a special filter for border detection. Sobel algorithm is used also for filtering. This is used for border and discontinuities detection. In Fig. 4 are shown two examples of kernels for Sobel. Fig. 5 illustrated its operation over a cell culture image.

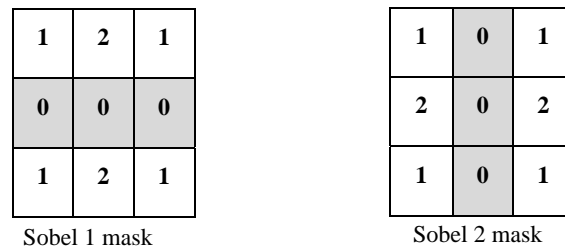

Fig. 4. Sobel kernels.

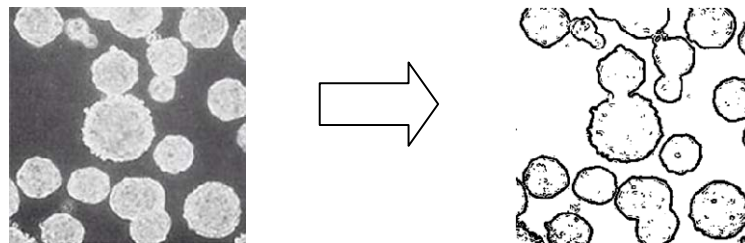

Fig. 5. Illustrating the Sobel operation.

3.2.2. Morphology algorithms

Morphology algorithms are applied for noise reduction and border and contour restoration.

- **Dilation:** It increases the number of bits of a contour region, enlarging this region and restoring also some holes around the contour (Fig. 6).

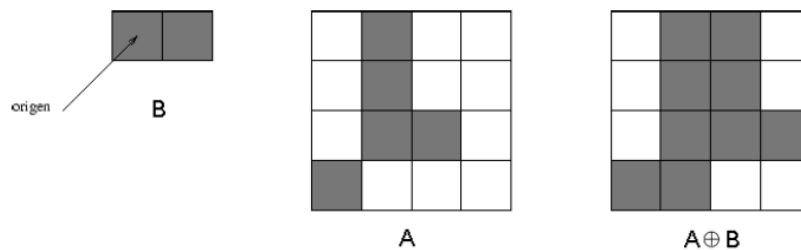

Fig. 6. Example of dilation. A represents the original image and B the structural element. $A \oplus B$ is the resulting image.

- **Erosion:** It works as the inverse of the dilatation. Some pixels are eliminated from contour, trying to smooth them (Fig. 7).

For both, erosion and dilation, it will be used as structural element, a start in which, the number of pixels in the main diagonal will define its size or length, Fig. 8.

- **Opening:** It is used for border smoothing and elimination of small peaks in a contour. It is defined as erosion plus dilation.
- **Closing:** It is used for elimination of small holes in contours and to close or put together next open contours. It is defined as dilation plus erosion.

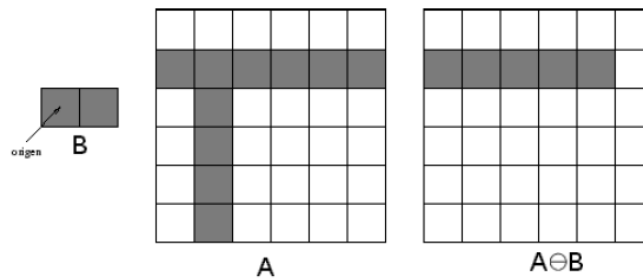

Fig. 7. Example of erosion. A represents the original image and B the structural element. $A \ominus B$ is the resulting image.

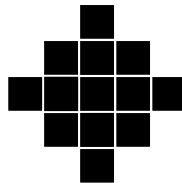

Fig. 8. Structural element of length 5 for dilation and erosion.

It has been incorporated also the possibility of the inverting black and white colors, since the tool will considers always the background in white color during processing. Color images can be also considered as input. Their processing needs a black-and-white conversion.

3.3. Image Catalog

The image histogram changes strongly from one image to another. The histograms were classified into five categories. For each one, the processing function parameters were customized to increases the quality of segmentation. The parameter values are fixed, but can be modified by the user in manual mode. Fig. 9 shows the corresponding histograms:

- **Cat 1:** The histogram has an absolute maximum much bigger than the rest.
- **Cat 2:** The histogram has only a main slope. All pixels are near zero, and there are only few grey levels.
- **Cat 3:** The histogram only has a main slope. All pixels are near to 255 level and, there are few grey levels.
- **Cat 4:** The image histogram has a non-uniform background.
- **Cat 5:** The histogram has two well separated peaks.

Based on this experience, the program has a proposal for image processing once each one has been classified [17]. If not possible, as in images type 4, the manual mode is employed. For example, in

images Cat 1, are required five steps: 1. Binarization plus Sobel. 2. Black&White inversion for background. 3. Add images from points 1 and 2. 4. Closing (5). 5. Opening (3).

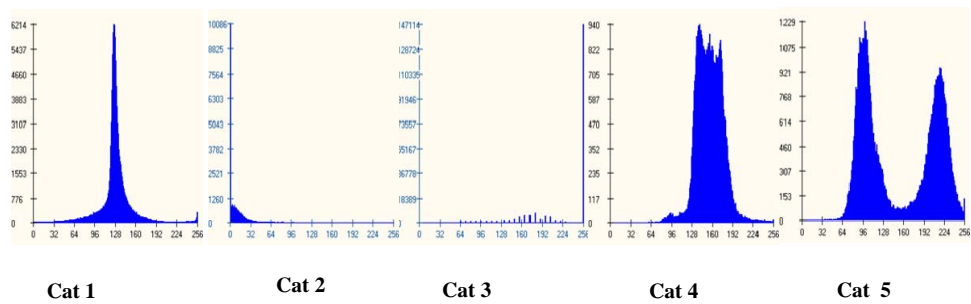

Fig. 9. Image histogram catalog.

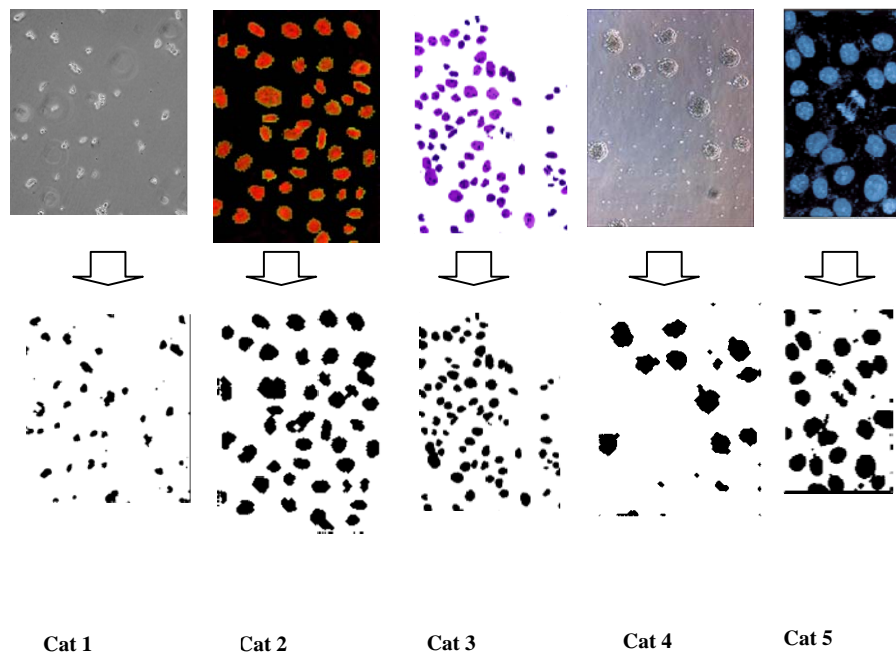

Fig. 10. Original and processed images for the five types of histograms considered.

4. The Sensor Electrode

Two operations are developed from the electrode panel. First, a scale is defined, allowing the real dimensioning. The user can evaluate the involved dimensions and set the specific tool developed for this purpose. A 100 μm scale is set by default as input. Secondly, the sensor (squared) size is defined on the menu. Only squared shapes were considered for electrodes (Fig. 1) but this can be extended to any other shape. The main panel shows the final position for electrodes under the cell culture. In this paper, it has been considered that optimal electrodes must be sized similar to cell dimensions. The impedance sensor in Fig. 1 has two microelectrodes (e_1 and e_2). When measuring, both are in contact with saline solution medium, and have or not part of its surface covered by cells. To generate the corresponding AHDL models, first it has been considered the electrode-solution model described in [5]. Fig. 11a shows the equivalent circuit. It has four circuit elements: double layer capacitance, C_{dl} , transfer resistance, R_t , Warburg impedance, Z_w and the spreading resistance, R_s . When the sensor surface (A) it is partially covered by cells an area A_c , this circuit can be modified, Fig. 11b, creating

two branches (covered and not covered by cells). The R_{gap} resistance models the cell-electrode interface [12]. The program will generate automatically the AHDL model for each electrode considering its fill factor, ff . Reference electrodes (e_2) are not been considered because of they are common for all sensors and its total area is large (with low resistive effects).

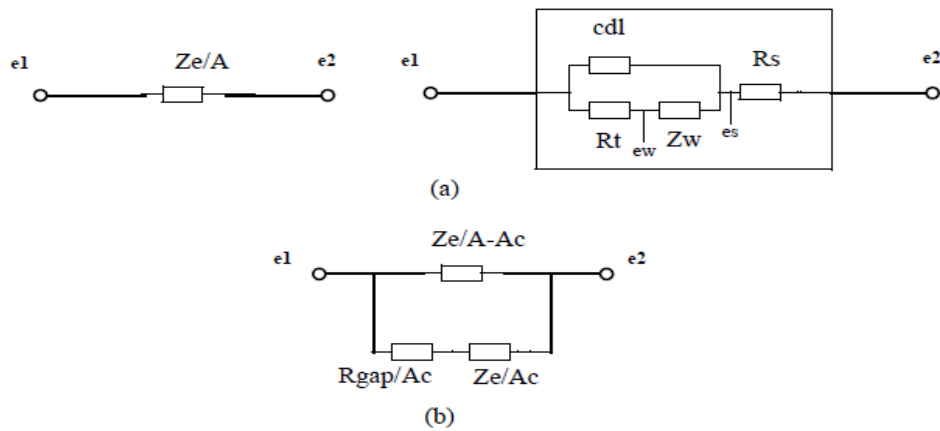

Fig. 11. Circuit elements in the electrode model for: (a) An electrode of area A. (b) An electrode of area A, partially covered by cells and area A_c .

5. Electrode AHDL Model

Based on circuits in Fig. 11, it has been developed the AHDL description for each bioimpedance sensor. It has been considered only the effect of sensing electrode (e_1 in Fig 1). Considering Figs. 11(a) and (b), the AHDL code in Fig. 12 represents the model of an electrode of area A, covered by cell a percent ff , at temperature T . Each electrode in Fig. 11b is described by a HDL module in Fig. 12. In Fig. 13 it is shown the complete the capacitor double layer HDL code as an example of the technological description of this circuit element.

6. Measurements

Area measurements can be done by detecting the cell-electrode area overlap. For each electrode, this process delivers the fill factor (ff) in the range $[0, 1]$ representing the percent of electrode area covered by cells. These data are expressed in a matrix that can be displayed on the main panel. Also, information is stored in a data file compatible with other computer tools such as MATLAB. The cell number, cell count, at the image is approximated by defining the radius of a circular cell as a pattern. Other cell shapes can be easily considered. The main motivation to develop this tool is for the fast input processing of information from cell culture images. The circuit design in Fig. 1 is dependent on load to be sensed, in our case the cells, being necessary to adjust the circuit specifications to impedance values of electrode-solution-cell system and to select the optimum working frequency. The program does a fast generation of circuit model from a cell culture image in AHDL, useful for SpectreHDL mixed-mode simulator. Fig. 14 shows an example, where each electrode is described with its corresponding area and fill factor.

In the example, the input image is a cat 5 histogram like. The electrode/sensor size chosen is $50 \times 50 \mu\text{m}^2$. The center panel image displayed in Fig. 14 shows the sensor grid obtained. Each square represents an impedance sensor, as illustrates Fig. 1. The measurement panel shows the fill factor matrix obtained, in which each number represents the cell-electrode overlapping area percent for a

given electrode. Also, considering a radius of $35\mu\text{m}$ for circular cells, 22 cells have been found in the image. Finally, Fig. 15 shows the file where the AHDL description of the electrode array is codified. Each line describes an electrode sensor in terms of its situation, area and fill factor, for electrical simulations. The area, in the last electrodes, considers the border effects derived from electrode size selection. Electrical simulations can take advantage of using this AHDL circuit description for microelectrode-cell system [18], allowing a confident matching for loads obtained from cell culture images [19].

```

module electrode (e1,e2) (A,ff,T)
node [V,I] e1, e2;
parameter real A=2500e-12 ;
parameter real ff=0.0;
parameter real T=273;
{
module electrode_solution(e1,e2) (A,ff,T);
module electrode_solution_covered(e1,e2) (A,ff,T)
}

module electrode_solution(e1,e2) (A,ff,T)
node [V,I] e1, e2;
parameter real A=2500e-12 ;
parameter real ff=0.0;
parameter real T=273;
{
node [V,I] ew, es;
capacitor_double_layer cdl(e1,es) (A,1-ff,T);
resistor_transfer Rt(e1,ew) (A,1-ff,T);
impedance_warburg Zw(ew,es) (A,1-ff,T);
resistor_spread Rs(es,e2) (A,1-ff,T);
}

module electrode_solution_covered(e1,e2) (A,ff,T)
node [V,I] e1, e2;
parameter real A=2500e-12 ;
parameter real ff=0.0;
parameter real T=273;
{
node [V,I] elg, ew, es;
resistor_gap Rgap(e1,elg) (A,ff,T);
capacitor_double_layer cdl(elg,es) (A,ff,T);
resistor_transfer Rt(elg,ew) (A,ff,T);
impedance_warburg Zw(ew,es) (A,ff,T);
resistor_spread Rs(es,e2) (A,,ff,T);
}

```

Fig. 12. HDL code for an electrode of area A, partially covered by cells an area Ac.

```

module capacitor_double_layer(pin,nin) (area,ff,T)
node [V,I] pin,nin;
parameter real area=2500e-12;
parameter real ff = 0.0;
parameter real T=273;
{
real perm_o = 8.85e-12;
real perm_r = 6;
real q =1.6e-19;
real K=1.38e-23;
real dohp = 5.0e-10;
real ch = perm_o * perm_r / dohp ;
real no_ions = 93e18;
real z_ions = 1.0;
real e_charge =1,6e-19;
real vo_dl = 0.050;
real v_thermal = K*T/q;
real len_debye = sqrt((perm_o*perm_r*v_thermal)/ (2.0*no_ions*z_ions*z_ions*e_charge) );
real cg = (perm_o*perm_r/len_debye) * cosh(z_ions*vo_dl/2.0*v_thermal) ;
analog
    I(pin,nin) <- cdl * dot(V(pin,ini)) * (area*ff);
}

```

Fig. 13. SpectreHDL code for the capacitor double layer (cdl) circuit element.

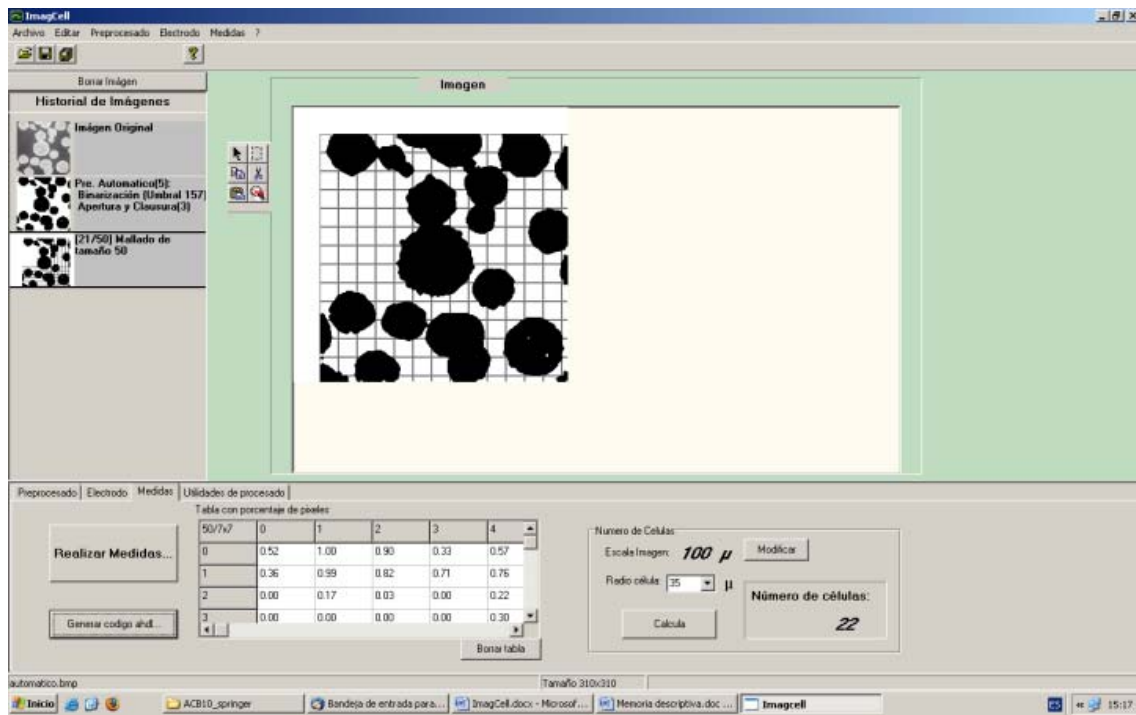

Fig. 14. Tool interface example: measuring area covered by cells and number of cells.

```

module electrode_2D(e1,e2)
node [V,I] e1[15], e2[15]
{
electrode elec_1_1(e1[1],e2[1])(2500,0.52,T);
electrode elec_1_2(e1[1],e2[2])(2500,1.00,T);
electrode elec_1_3(e1[1],e2[2])(2500,0.90,T);
.....
electrode elec_14_13(e1[14],e2[13])(350,0.24,T);
electrode elec_14_14(e1[14],e2[14])(49,0.94,T);
}

```

Fig. 15. SpectreHDL file for the electrode matrix: Area ($2500 \mu\text{m}^2$) and fill factor (0.52 for sensor in position (0,0)).

7. Conclusions

This paper describes a tool for computer aid in cell culture image processing useful for bio-impedance measurement systems based on microelectrode sensors. The program performs image segmentation based on threshold algorithms, focused on cell location. A wide number of cell culture images were analyzed and classified including them into the database. The bio-impedance sensor-electrode design was specified for optimum sizing on the basis of electrode-cells area overlap. Resulting data from image processing and electrode sizing allows the automatic description of sensor-cell culture system in AHDL format, useful for mixed-mode electrical simulations.

References

- [1]. Ackmann, J., Complex Bioelectric Impedance Measurement System for the Frequency Range from 5Hz to 1MHz, *Annals of Biomedical Eng.*, Vol. 21, 1993, pp. 135-146.
- [2]. Beach, R. D., et al., Towards a Miniature In Vivo Telemetry Monitoring System Dynamically Configurable as a Potentiostat or Galvanostat for Two- and Three- Electrode Biosensors, *IEEE Transactions on Instrumentation and Measurement*, Vol. 54, No.1, 2005, pp. 61-72.

- [3]. Yúfera, A. et al. A Tissue Impedance Measurement Chip for Myocardial Ischemia Detection, *IEEE Transaction on Circuits and Systems I*, Vol. 52, 12, 2005, pp. 2620-2628.
- [4]. Radke, S. M., and Alocilja, E. C. Design and Fabrication of a Microimpedance Biosensor for Bacterial Detection, *IEEE Sensor Journal*, Vol. 4, No. 4, 2004, pp. 434-440.
- [5]. Borkholder, D. Cell-Based Biosensors Using Microelectrodes, PhD Thesis, *Stanford University*, 1998.
- [6]. Giaever, I. et al. Use of Electric Fields to Monitor the Dynamical Aspect of Cell Behaviour in Tissue Culture, *IEEE Transactions on Biomedical Engineering*, BME-33, 2, 1986, pp. 242-247.
- [7]. Holder, D., Electrical Impedance Tomography: Methods, History and Applications, *IOP*, Philadelphia, 2005.
- [8]. Romani, A. et al., Capacitive Sensor Array for Location of Bioparticles in CMOS Lab-on-a-Chip, *ISSCC*, 2004.
- [9]. Medoro, G., et al. A Lab-on-a-Chip for Cell Detection and Manipulation, *IEEE Sensor Journal*, Vol. 3, No. 3, 2003, pp. 317-325.
- [10]. Maresca, N., et al, A CMOS Chip for individual Cell Manipulation and Detection, *IEEE Journal of Solid Stated Circuits*, Vol. 38, No. 12, 2003, pp. 2297-2305.
- [11]. Hassibi, A., et al., A Programmable 0.18 μm CMOS Electrochemical Sensor Microarray for Biomolecular Detection, *IEEE Sensor Journal*, 2006, pp. 1380-1388.
- [12]. Huang, X. et al., Simulation of Microelectrode Impedance Changes Due to Cell Growth, *IEEE Sensors Journal*, Vol. 4, No.5, 2004, pp. 576-583.
- [13]. Yúfera, A. et al., A Method for Bioimpedance Measure With Four- and Two-Electrode Sensor Systems, *30th IEEE EMBS*, Vancouver, 2008, pp. 2318-2321.
- [14]. Yúfera et al., A CMOS Bio-Impedance Sensor System for Cell Culture Monitoring, *IEEE Circuits and Systems for Medical and Environmental Applications Workshop, CASME*, Mérida, Mexico, 14-16 Dec., 2009.
- [15]. Joye, N., et al., An Electrical Model of the Cell-Electrode Interface for High-density Microelectrode Arrays, *IEEE EMBS*, 2008, pp. 559-562.
- [16]. SpectreHDL Reference Manual, *Cadence Design Systems Inc.*
- [17]. Yúfera, et al., ImagCell: A Computer Tool for Cell Culture Image Processing Applications in Bio-Impedance Measurements, Chapter in Software Tools and Algorithms for Biological Systems, in book series: *Advances in Experimental Medicine & Biology, Springer*, To appear, 2011.
- [18]. Yúfera and A. Rueda, Design of a CMOS closed-loop system with applications to bio-impedance measurements, *Microelectronics Journal*, Vol. 41, Apr. 2010, pp. 231-239.
- [19]. Yúfera and A. Rueda, Design of A CMOS Closed-Loop System Useful for Bio-Impedance Measurements. *IEEE International Conference Electronics Circuits and Systems, ICECS 2009*, Tunisia. Dec, 2009, pp. 948-951.

2011 Copyright ©, International Frequency Sensor Association (IFSA). All rights reserved.
(<http://www.sensorsportal.com>)

BioMEMS 08

Yole's BioMEMS report up to 2012

**IFSA offers
a SPECIAL PRICE**

How Microsystems and Semiconductor Industries make money out of the Life Science market?

The report will enable you to:

- Understand the Life Science market and define your strategy to address it
- Understand the main regulatory requirements (FDA, EMEA, JMHLW...)
- Get an overview of the main techniques in use or under development and the trends for the coming years
- Understand the real added value of Microsystems and Semiconductors to the Life Science industry
- Understand the main MEMS and Semiconductors success stories in the Life Science market

<http://www.sensorsportal.com/HTML/BioMEMS.htm>

