

EMI Interference Suppression in Symmetrical non-regulated Power Supply for High Immunity Audio Power Amplifier.

F.P. Ridao, J.M. Carrasco, and L.G. Franquelo.

Dpto. Ingeniería Electrónica.

Escuela Superior de Ingenieros de Sevilla.

Camino de los Descubrimientos s/n, 41092- Sevilla, SPAIN.

Tlf: +34-954487362, Fax: +34-954487373.

E-mail: carrasco@gte.esi.us.es

Keywords

EMI, EMC, Interference, Power Supply, Power Amplifier.

Abstract

Different non-regulated symmetrical power supplies for audio power amplifier are presented in this work, where the conducted interference to the ac power grid, measured by a LISN, has been suppressed to the minimum. EMI measurements in different topologies have been compared in this paper. Also, several conventional EMI suppression components have been tested in these topologies in order to reduce EMI interference. As a result several rectifier circuits for main power supply with very low emissions are presented in this paper based on fast rectifier diodes.

1. Introduction

In order to fulfil EMC standards in linear power amplifier, measurements of the conducted interference to the ac power grid have to be made using a Line Impedance Stabilization Network equipment (LISN) an EMI receptor, and normalized ground plane. Under these working conditions, different EMC standards fix the maximum emissions limits that can not be exceeded [1]. As a result, commercial power supply designs are limited by maximum EMC emission limits.

In certain applications, power supply circuits are very simple due to they do not require a precise regulation of the output voltages. For instance, this is the case of the main power supply in linear power amplifiers. Nevertheless, in this case also, the low level interference requirements of the load can have lower limits than those established in the generic and product EMC European standards (EN-50081-1, EN55013), when the system has been designed considering EMI problems that can affect the high susceptibility of the load (audio power amplifier) [2]. In this case, it is necessary to study and analyze different topological solutions that can reduce the generated interference in the power supply circuit for linear power amplifier [3].

In this paper, different techniques to reduce EMI interference in the non regulated power supply of a Linear Power Amplifier have been presented. The proposed techniques have been applied successfully to the power supply of an industrial power amplifier with high immunity against radiofrequency interference where switching power supplies have been avoided due to the high level of the generated EMI interference [4].

2. EMI measurement comparison in different isolated rectifier topologies.

As it was mentioned in previous section, the main design criteria of the power supply of a special Linear Power Amplifier is the reduction of internal and external EMI interference to the minimum. This is the reason that switching power supplies have been avoided for that application [4,5].

Therefore, several non regulated power supplies have been studied and analyzed and different topological solutions of the rectifier circuit have not been discarded due to have lower performance, but the main design criteria has been reduce EMI interference to the minimum.

As is shown in Fig. 1, EMC measurements have been done in different rectifier topologies of symmetrical power supply circuits, using as isolator a power transformer (220/35+35V, 300VA). Fig. 2 and Fig. 3 show conducted EMI spectrums and EMC limits (quasipeak values) using LISN EMCO 3810/2 and Tektronix 2712 spectrum analyzer at worse case (peak value measurement) . As a conclusion of these results we can say that the different topological solutions considered in this paper do not achieve a significant reduction of the generated interference when the same type of standard (discrete or integrated) rectifier diodes have been used.

In Fig. 4 is shown several circuits, that have been measured in this paper, in order to try to characterize the EMI interference generation, since they modify the rectified current waveforms (EMI problem is due to EMI differential propagated input current, as is show in the Fig. 6). However, it is possible to demonstrate experimentally that interference reduction, in the best case, is very low (Fig. 5) in comparison with techniques that it will be presented in next section.

3. EMI Suppression main rectifier circuits using fast recovery diodes

Measurements shown in previous figures demonstrate that internal generated interference is produced by input current and standard rectifier diodes. In order to reduce EMI interference to the minimum, standard (low frequency) diodes of the rectifier circuit have been replaced to different fast recovery diodes (only used in high frequency switching converters).

Fig. 7 shows different fast rectifier circuits tested and measured and Fig. 8 and 9 show the conducted interference spectrum. As a result, it is interesting to underline that the six fast diodes circuit proposed in this paper reduces drastically EMI interference without a significant performance reduction as is shown in Fig 8. In this case, power supply for audio power amplifier, the voltage drop in the diode (0.7 V) is much lower that the typical output voltages (+/-50 V).

Fig. 10 shows an oscilloscope register (with 50 Ω input impedance) of the LISN voltage and rectified output current in the secondary of the power transformer represented in the circuit of Fig. 7(A). As it is possible to observe a sudden switch off of the standard diode (D1 in Fig. 7A) produces an voltage pulse with high level frequency harmonic contents that don't appeared in the branch of diode D2 (D2 is a fast recovery diode, BYW29-200).

4. EMI coupling path with power amplifier circuit.

In previous section, interference conducted to the grid through different symmetrical supply circuits have been measured. These circuits have designed specially for lineal power amplifier systems. As a result of these measurement, it can be concluded first of all that a change in the rectifier circuit topology doesn't affect the reduction of generated EMI interference and secondly that with the use of fast diodes the interference generated and conducted to the grid can be eliminated.

However when the interference conducted to the load are measured (Fig.11), it is no possible to observe the EMI problem associate to the rectifier diodes (even in the worst case, with standard

rectifier diodes) because the high capacitance value of the output filter eliminate the differential mode EMI interference in the power supply outputs.

In all the supply circuits for power amplifier that have been analyzed the low frequency isolation have been implemented by a transformer with toroidal or E-I core. It has been also determined that the EMI interference coupling with the load is due to the near magnetic field, as it is show in Fig. 12 for two different transformer cases. In this figure is show that the worst case of high frequency magnetic field pulse coupling between power transformer and high susceptibility power amplifier circuit is associated to the standard rectifier diode recovery.

5. Conclusions

In this work, EMI interference conducted to the grid has been measured in different load conditions and different symmetrical non regulated power supplies for a special high immunity audio power amplifier.

The first conclusion is that the use of conventional solutions or changes of the rectifier circuit topology in the power supply do not affect significantly the reduction in high frequency interference. In spite of that, different rectifier circuits have been proposed in this paper using fast diodes reducing EMI interference to the intrinsically measurement noise level.

References

- [1] Chris Marshman. *Guide to the EMC Directive 89/336/EEC*. IEEE Press. 1996.
- [2] J. P. Mills. *Electromagnetic Interference reduction in electronic systems*. Prentice- Hall.1993.
- [3] L. Tihanyi. *Electromagnetic Compatibility in Power Electronics*. IEEE Press. 1995.
- [4] F.P. Ridao, J.M. Carrasco, and L.G. Franquelo. “*EMI suppression techniques comparison in a double AC/DC PWM switching converter to be used in Linear Power Systems*”. European Conference on Power Electronics and Applications, EPE’ 99, Suiza, September1999.
- [5] F.P. Ridao, J.M. Carrasco, and L.G. Franquelo. “*Conducted Interference (EMI) suppression in a power supply of a linear power system.*”. The 25th Annual Conference of the IEEE Industrial Electronics Society, IECON’99, California, November 1999.

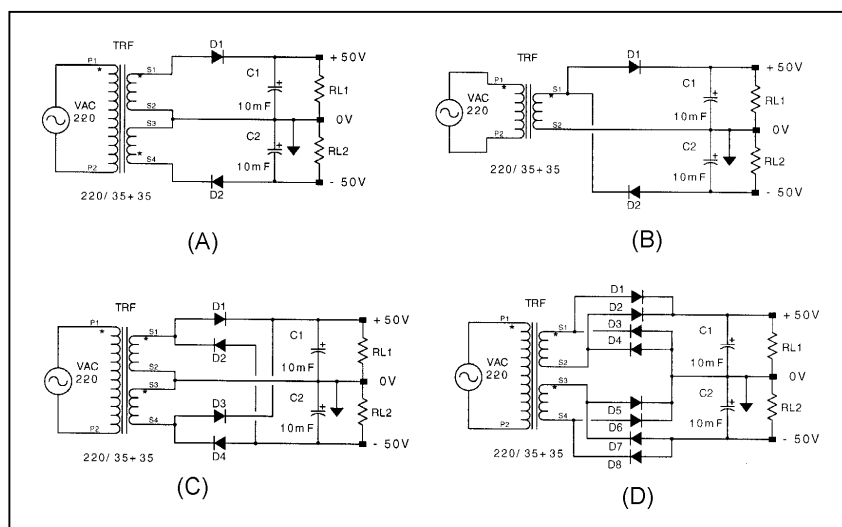

Fig. 1: Different topologies of symmetrical rectifier circuits analyzed in this paper.
 a) Symmetrical half wave rectifier. b) Asymmetrical half wave rectifier. c) Simple full bridge rectifier. d) Double full bridge rectifier.

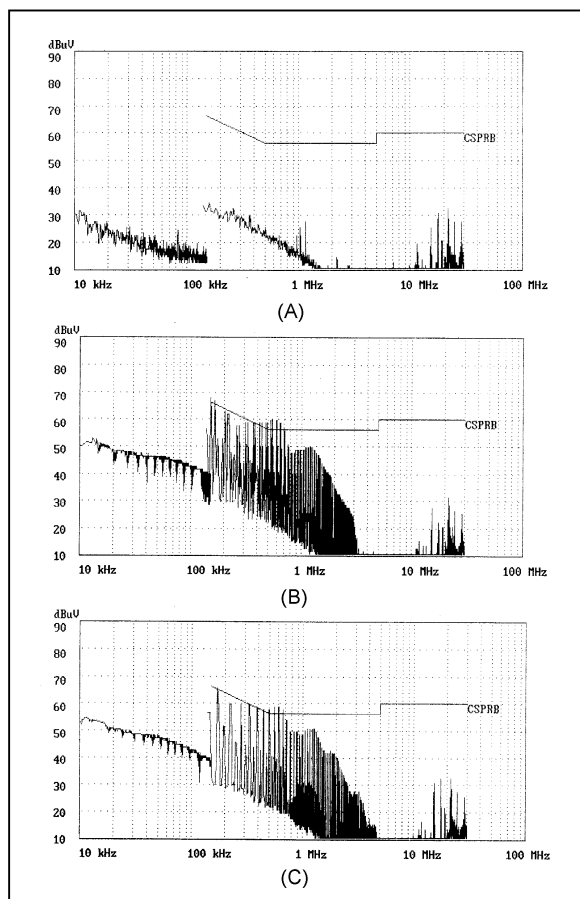

Fig. 2: Conducted EMI interference in the symmetrical simple full bridge rectifier circuit for different load conditions.
 a) No load. b) $I_o=1+1A$. c) $I_o=2+2 A$.

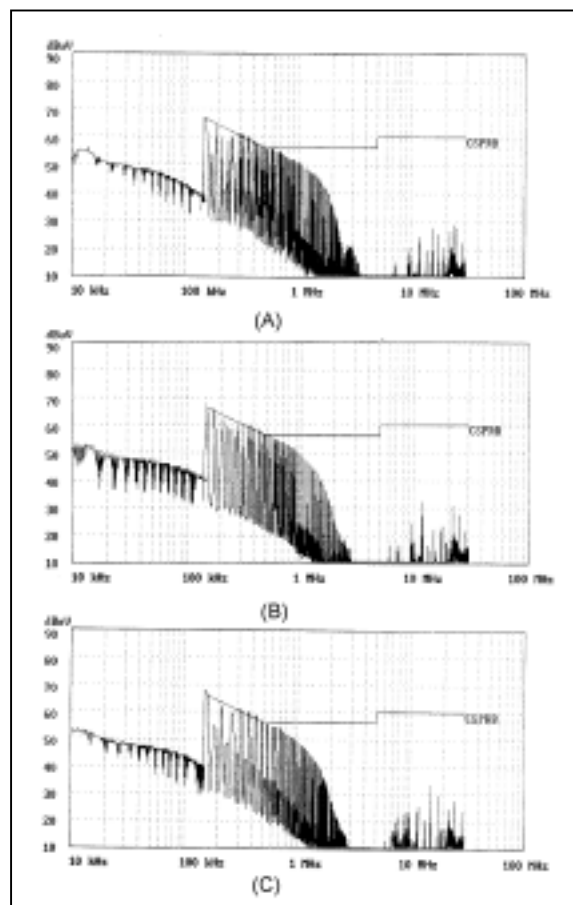

Fig. 3: Conducted EMI interference for different topologies of the symmetrical rectifier circuit. ($I_o=2+2 A$).
 a) Double bridge rectifier. b) Symmetrical half wave rectifier. c) Asymmetrical half wave rectifier.

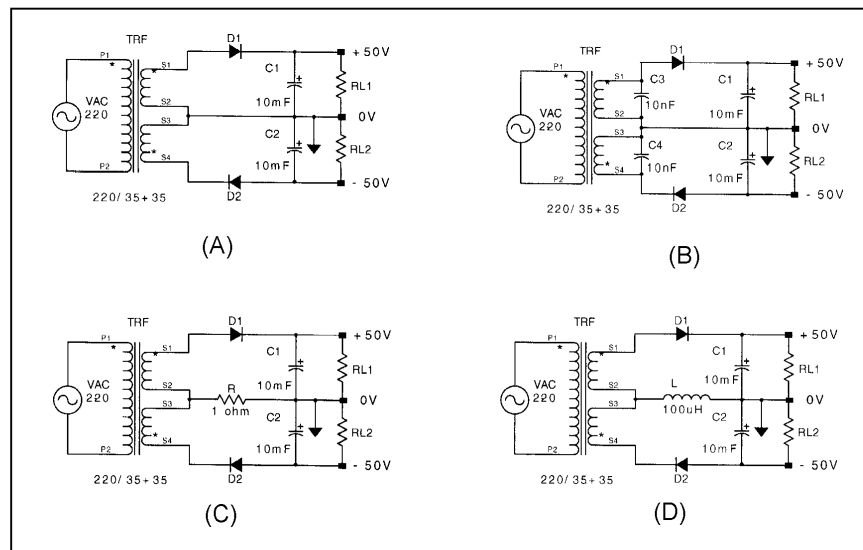

Fig. 4: Different circuit modifications (including EMI filter devices) in the symmetrical half wave rectifier circuit in order to measure EMI interference reduction. (a) Basic circuit. (b) Using two EMI filtering capacitor, C3 and C4. (c) Using a resistor R in order to limit EMI current. (d) Using an inductance L in order to limit the slope of EMI current

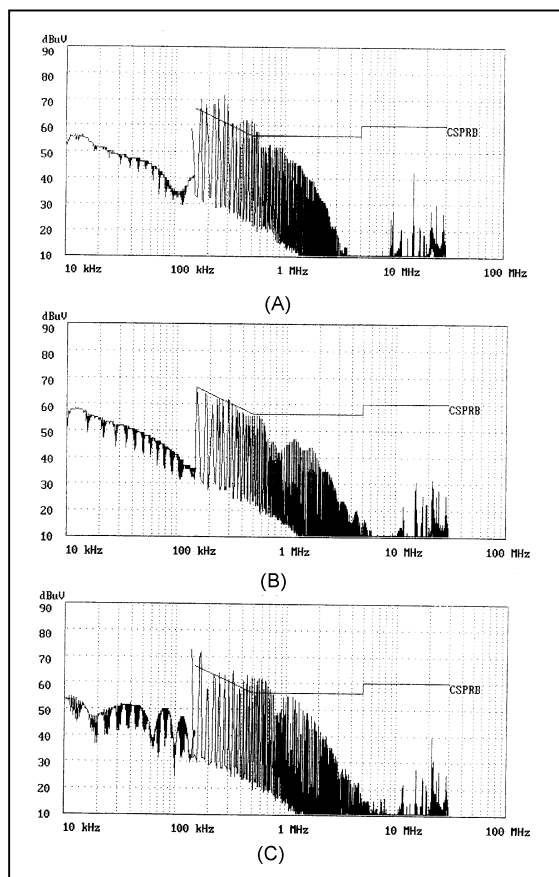

Fig. 5: Conducted EMI interference in the symmetrical half wave rectifier introducing different filtering components, as is shown in Fig. 2. a) Using two filtering capacitor, C3 and C4. b) Using a resistor R in order to limit EMI current. c) Using an inductance L in order to limit the slope of EMI current

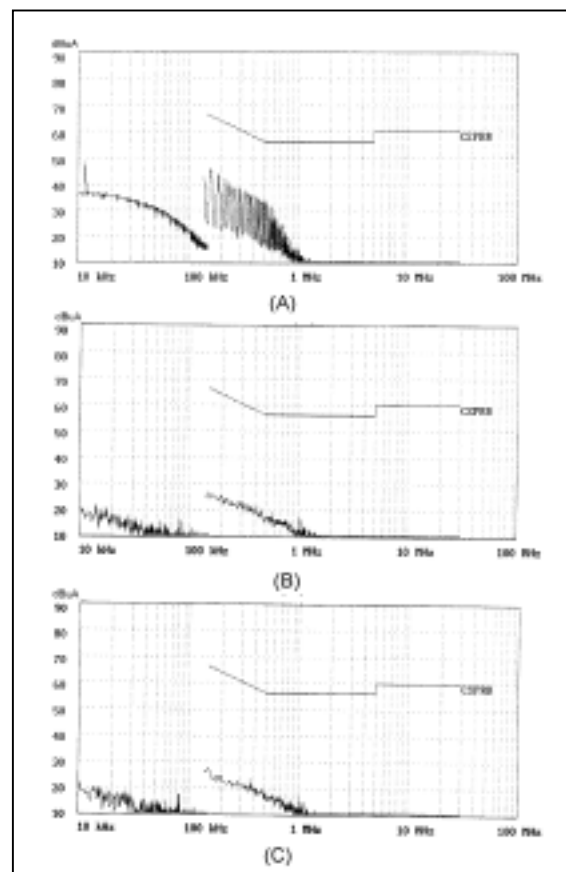

Fig. 6: EMI current in the half bridge rectifier circuit measured using RF ESH2-Z1 current probe ($I_0=2+2A$).
 a) EMI input current in differential mode.
 b) EMI input current in common mode.
 c) EMI output current in differential mode.

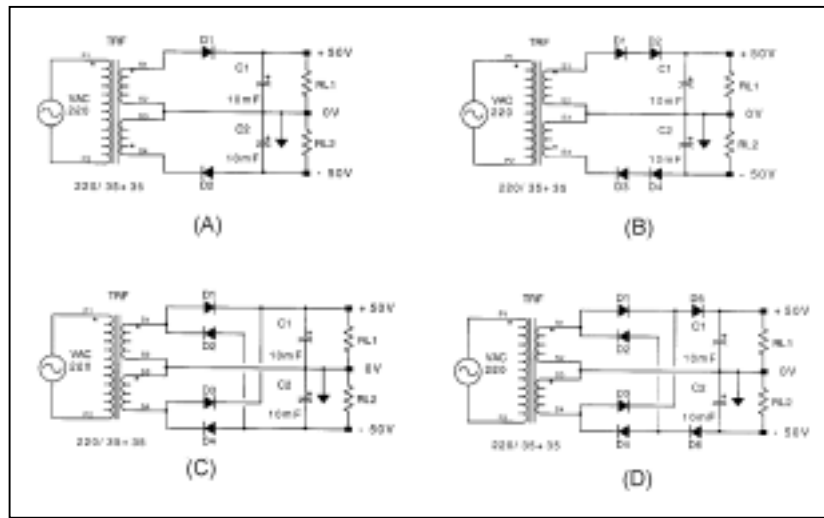

Fig. 7: Very low EMI main rectifier circuit based on the use of fast recovery diodes. a) Symmetrical half wave circuit using only one diode in each branch. b) Symmetrical half wave circuit using two diodes in each branch. c) Full bridge circuit using four diodes. d) Proposed full bridge circuit using six diodes.

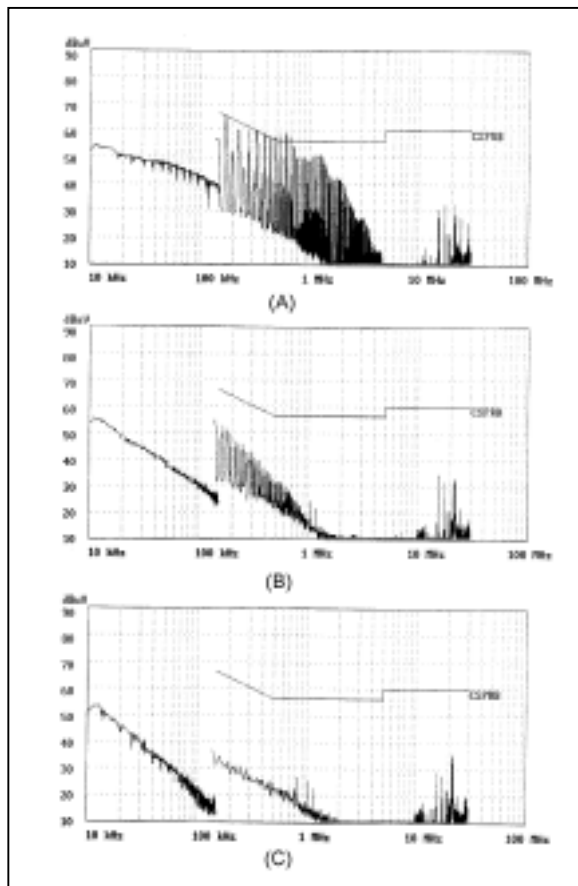

Fig. 8: Conducted EMI interference in different full bridge rectifier circuits. a) Using standard integrated rectifier diodes FB2506. b) Using four fast recovery diodes BYW29-200. c) Using six fast recovery diodes BYW29-200

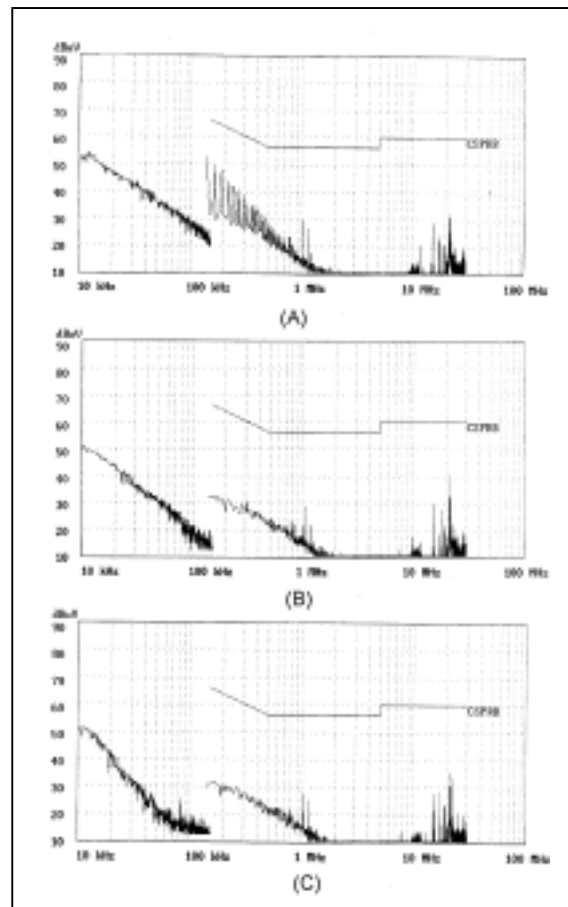

Fig. 9: Conducted EMI interference in symmetrical half wave rectifier circuits with different fast recovery diodes in each branch as is shown in Fig. 7. a) Using an only one diode. b) Using two diodes. c) Using three diodes.

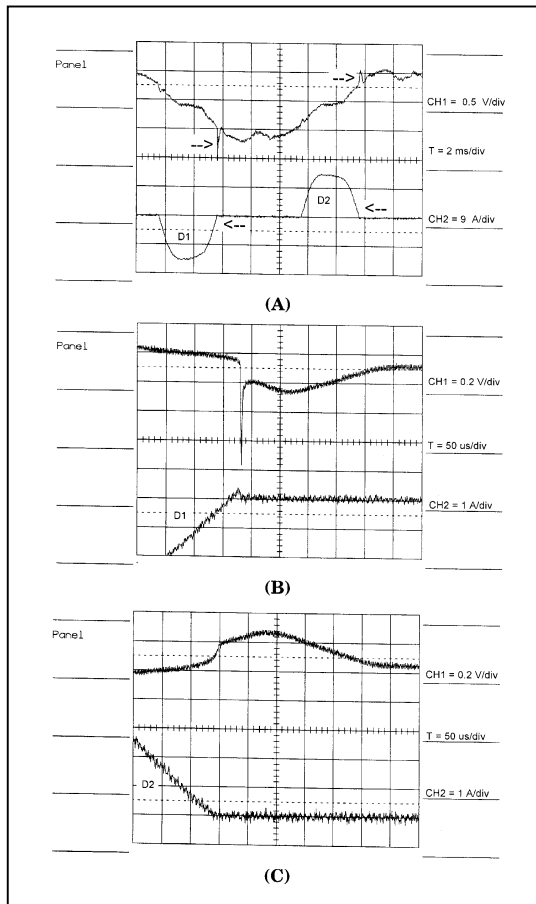

Fig. 10: Oscilloscope of the LISN output voltage and rectifier current measured in a symmetrical half wave rectifier circuit for load condition of $I_o=2+2A$, using D1 standard diode and D2 fast recovery diode as is shown in Fig. 7 a)

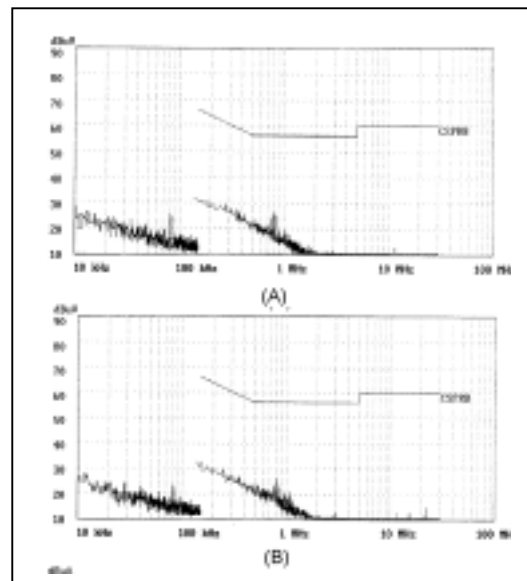

Fig. 11: EMI conducted interferences in the output voltages, measured in differential mode, for $I_o=2+2A$, using standard diode (worst case) as rectifier circuit. a) +50V output measurement. b) -50V output measurement.

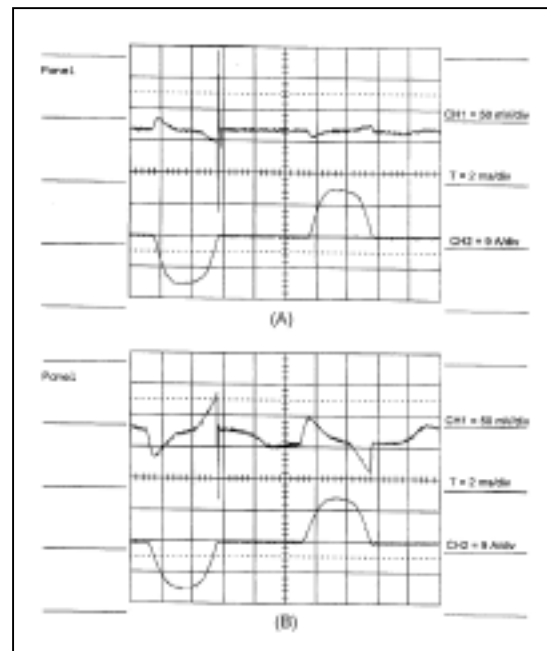

Fig. 12: Oscillograms of the voltage measure in the power transformer, using a near magnetic field probe, for the symmetrical half wave rectifier with different kind of diodes (D1 standard diode and D2 fast diodes). a) Using a 300VA transformer based on a toroidal core. b) Using a 300VA transformer based on a E-I core.