

Journal of Building Engineering

LONG-TERM ENVIRONMENTAL MONITORING FOR PREVENTIVE CONSERVATION OF EXTERNAL HISTORICAL PLASTERWORKS

--Manuscript Draft--

Manuscript Number:	JBE-D-21-03287R2
Article Type:	Research Paper
Section/Category:	Building materials
Keywords:	plasterwork; temperature; relative humidity; architectural heritage; preservation
Corresponding Author:	VICENTE FLORES-ALÉS, Ph.D. Universidad de Sevilla SEVILLE, SPAIN
First Author:	Marta Torres-González, PhD aspirant
Order of Authors:	Marta Torres-González, PhD aspirant Carlos Rubio-Bellido, Ph. D. David Bienvenido-Huertas, Ph. D. Juan Manuel Alducin-Ochoa VICENTE FLORES-ALÉS, Ph.D.
Abstract:	<p>In this study, an analysis of the environmental conditions in a Csa climatic zone for the conservation of plasterwork of the Real Alcázar of Seville is carried out. The measurements obtained from in-situ monitoring are compared with the measurements provided by AEMET (State Meteorological Agency in Spain) during the reference year and the study is completed by estimating future environmental conditions using two alternative approaches: a morphing process from the EPW of the climatic zone and the application of M5P data mining algorithms.</p> <p>An optimal temperature range is established for the conservation of the plasterwork that prevents their dehydration or the freezing of water particles contained. The transformation of gypsum into bassanite, the risks associated with exposures to high relative humidity and the consequences of the slight hygroscopicity of the material and the environmental conditions that must be developed to favor the growth of mold on the surface or the cracking of polychromies that embellish these plaster decorations on numerous occasions are analyzed. The results obtained allow us to establish preventive conservation measures not only on the plasterwork but also on the Real Alcázar of Seville and that architectural heritage located in the subtropical dry-summer climate.</p>
Suggested Reviewers:	<p>David Sanz, Ph. D. Lecturer, Polytechnic University of Madrid: Universidad Politecnica de Madrid david.sanz.arauz@upm.es He is an expert research about heritage and traditional materials. He is specialized in the study of gypsum.</p> <p>Ana Silva, Ph. D. Research, University of Lisbon Higher Technical Institute: Universidade de Lisboa Instituto Superior Tecnico ana.ferreira.silva@tecnico.ulisboa.pt Dra. Silva is a researcher with an extensive experience in building service life prediction and durability.</p>
Opposed Reviewers:	
Response to Reviewers:	<p>Dear editor:</p> <p>We have received the second revision of our manuscript JBE-D-21-03287R1 "LONG-TERM ENVIRONMENTAL MONITORING FOR PREVENTIVE CONSERVATION OF EXTERNAL HISTORICAL PLASTERWORKS".</p>

#Reviewer 1 now consider it in conditions for acceptance, but the review of #Reviewer2 is the same that we received previously- it means the same comments and the same pdf attached for minor comments that we considered in the second version of our manuscript. As we indicated in the previous revision, all the suggestions have been taken into consideration. The text was rewriting to improve the comprehension and highlighted in yellow colour

Journal of Building Engineering

Dear Editor:

Let me introduce myself, my name is Vicente Flores-Alés and I am a Material Science Lecturer at the University of Sevilla (Spain). I submit the manuscript entitled “LONG-TERM MONITORING FOR PREVENTIVE CONSERVATION OF HISTORICAL PLASTERWORKS” for your consideration in order to be published in Journal of Building Engineering.

The aim of this paper is evaluating the influence of environmental conditions on the conservation of historical plasterwork. The chosen case study is the Real Alcázar of Seville and was based on (i) the annual monitoring of the environmental parameters Temperature and Relative Humidity, (ii) the estimation of hourly values in future scenarios using artificial intelligence and (iii) the use of the threshold values for the conservation of plasterwork defined in the literature.

Look forward to your favourable consideration.

Most sincerely,



Vicente Flores Alés



Authors: Marta Torres-González, Carlos Rubio-Bellido, David Bienvenido-Huertas, Juan Manuel Alducin-Ochoa, Vicente Flores-Alés(*)

[*Corresponding author]

Mailing address: Vicente Flores Alés, E.T.S.I.E., Avda/ Reina Mercedes, nº4A, 41012-Sevilla ESPAÑA. E-mail address: vflores@us.es Phone number: 34 954556656 Fax: 34 954556691

REVIEWER #1:

Thank you for your comments.

REVIEWER #2:

As we indicated in the previous revision, all the suggestions have been taken into consideration. The text was rewriting to improve the comprehension and highlighted in yellow colour

- The influence of temperature and relative humidity in the preservation of plasterwork.
- Comparative analysis between different approaches.
- Climate change will affect the maintenance of materials.
- Future estimations allow to establish mitigation actions on architectural heritage.

LONG-TERM ENVIRONMENTAL MONITORING FOR PREVENTIVE CONSERVATION OF EXTERNAL HISTORICAL PLASTERWORKS

Marta Torres-González ^{a,b} *, Carlos Rubio-Bellido ^a, David Bienvenido-Huertas ^a, JM Alducin-Ochoa ^a, V. Flores-Alés ^a,

^aDepartment of Architectural Construction II, University of Seville

^bDepartment of Civil Engineering, Architecture and Georesources, University of Lisbon

* Corresponding author: mtorres18@us.es , Av Reina Mercedes 4, Seville, 41012

KEYWORDS: plasterwork; temperature; relative humidity; architectural heritage; preservation;

ABSTRACT:

In this study, an analysis of the environmental conditions in a Csa climatic zone for the conservation of plasterwork of the Real Alcázar of Seville is carried out. The measurements obtained from in-situ monitoring are compared with the measurements provided by AEMET (State Meteorological Agency in Spain) during the reference year and the study is completed by estimating future environmental conditions using two alternative approaches: a morphing process from the EPW of the climatic zone and the application of M5P data mining algorithms.

An optimal temperature range is established for the conservation of the plasterwork that prevents their dehydration or the freezing of water particles contained. The transformation of gypsum into bassanite, the risks associated with exposures to high relative humidity and the consequences of the slight hygroscopicity of the material and the environmental conditions that must be developed to favor the growth of mold on the surface or the cracking of polychromies that embellish these plaster decorations on numerous occasions are analyzed. The results obtained allow us to establish preventive conservation measures not only on the plasterwork but also on the Real Alcázar of Seville and that architectural heritage located in the subtropical dry-summer climate.

1. INTRODUCTION

1.1 Thermo-hygrometric conditions and the conservation of the architectural heritage.

The preventive conservation of heritage is crucial so that future generations can know the identity traits of their culture [1]. Therefore, the monitoring and analysis of specific environmental conditions [2] and their impact on architectural heritage, as well as future vulnerabilities due to global warming [3], are currently a challenge.

There are numerous studies that analyze both the impact of environmental conditions on architectural heritage [4,5] and the conditioning of interior spaces to favor the preservation of objects (e.g., objects that belong to exhibitions) [6,7]. In both cases, there are national and international guidelines and standards that establish the interior air conditioning conditions of these buildings for such purposes, such as UNI 10829 Standard [8], UNE EN 15757 [9], ASHRAE STANDARD 55-2020[10] or the British PAS 198 [11]. Likewise, EN 15759-1 [12] also considers the possibility of using heating systems to achieve thermal comfort and for the optimal conservation of heritage elements.

In addition to international standards, numerous studies have carried out thermo-hygrometric monitoring of architectural heritage in recent decades, resulting in a very useful tool to assess the state of conservation of the building and to know the causes of the degradation in order to determine a future restoration intervention or to establish preventive conservation criteria, ruling out the use of destructive techniques. Thus, long-term studies of up to 20 years duration [13,14] and studies in which monitoring is limited to one year [15] have been published. In this regard, it is common to evaluate at least annual monitoring periods that are complemented by thermal models on which different estimates of environmental conditions are established. Environmental monitoring and simulation tools make it possible to establish estimates of different factors, such as the modification of operational patterns, thermal comfort [16-18], or

1 energy conservation measures [19]. However, the impact of climate change, the basis of
2 numerous investigations related to cities [20,21] has been sparsely discussed in reference to
3 preventive conservation of heritage and long-term adverse aspects, which could become very
4 significant [22,23].
5
6
7
8
9

10 **1.2 Relative humidity and temperature influence in the preservation of historical** 11 **plasterwork.** 12 13

14
15 There are studies about how ambient conditions could affect constructive materials [24–28] but
16 are insufficient with respect to gypsum or plasterwork. In this sense, it is worth highlighting the
17 importance of follow-up campaigns to identify possible risks for the conservation of the
18 plasterwork, prevent irreversible damage and advance conservation strategies. However, to
19 account for all the possible damage mechanisms, a comprehensive methodology should be
20 used to evaluate some risk indexes based on ambient temperature (T) and relative humidity
21 (RH) measurements.
22
23
24
25
26
27
28
29
30
31

32 Gypsum, due to its porous microstructure formed by crystalline groups of hydrated calcium
33 sulfate, can incorporate water molecules inside, in the form of water vapor or even in the form
34 of liquid water, when environmental conditions favor capillary condensation. Furthermore,
35 gypsum has the ability to eliminate this water when environmental conditions change, reducing
36 the content of water vapor in contact with the material [29].
37
38
39
40
41
42
43
44

45 Variations in T and RH can induce phase transitions. In general, gypsum ($\text{CaSO}_4 \cdot 2\text{H}_2\text{O}$)
46 dehydration occurs in dry environments [30], which is the reason why temperature below 40°C
47 is desirable for the correct preservation of plasterwork. However, there may be situations of
48 high temperatures combined with high relative humidity in which there are no alterations in the
49 mineral phases of the gypsum [31]. In this regard, Winkler & Wilhelm (1970) indicated the
50 relationship that must exist between ambient temperature and relative humidity to transform
51 gypsum ($\text{CaSO}_4 \cdot 2\text{H}_2\text{O}$) into bassanite ($\text{CaSO}_4 \cdot 0.5\text{H}_2\text{O}$) [31], In this case, the material is likely to
52
53
54
55
56
57
58
59
60
61
62
63
64
65

lose stability if exposure to these unfavorable environmental conditions is prolonged over time [32] (Fig. 1-A, 1-B).

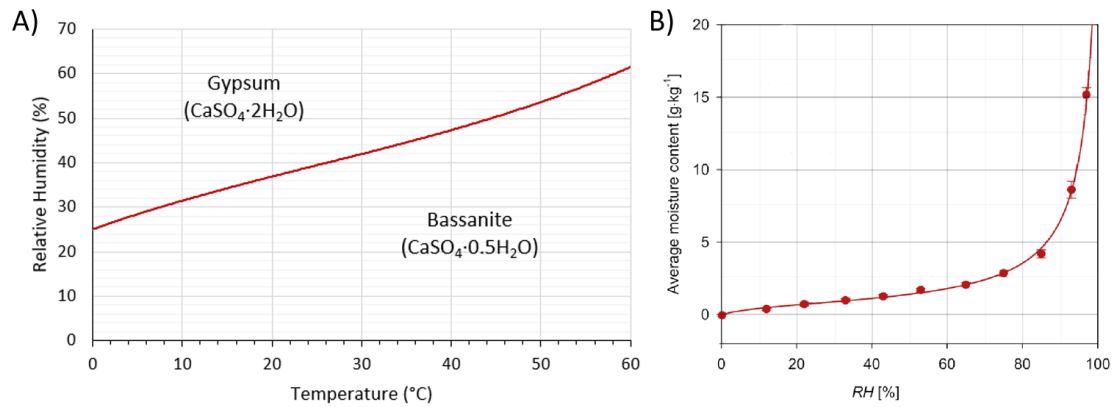

Fig. 1 (A) T-HR ratio for gypsum-bassanite transformation at 1 atmosphere pressure [31] and (B) Relationship between the relative humidity and the moisture content of the gypsum [33].

However, this transformation is part of a reversible process in plasterwork, which means that a rehydration would allow the recovery of the initial properties as long as the dehydration had not been prolonged in time until it remained constant, due to a change in climatic conditions, causing the mechanical weakening of the plasterwork [32].

Additionally, gypsum has low hygroscopicity [33,34] and medium-low solubility [35] that do not represent a direct risk in the preservation of plasterwork [36]. However, it is important to control the environmental conditions because the condensation of moisture on the surface of the plasters favors the alteration of the polychrome binders and their possible detachment [33]. The adsorption hygroscopicity of gypsum with 80% RH is only 4 g/kg (0.4%) [33], reaching a high adsorption hygroscopicity only by capillary saturation (99% RH) [34]. Likewise, humidity favors the nesting of biotic organisms and the alteration derived from their activity [33]. Therefore, an RH close to or greater than 90% weakens the structure of the plasterwork and favors the proliferation of microorganisms and biological agents, as well as the fixation of environmental pollutants.[37–39] (Fig. 01-B).

1 The concentration of water vapor inside rooms can produce condensation dampness in the
2 sufficiently cold walls, which can generate the appearance of molds or small fungi in the plaster
3 decorations in the absence of ventilation [29]. The appearance of mold or the growth of
4 organisms would therefore be another factor that accelerate the degradation of plasterwork
5 [40]. However, and taken into account that this fact depends on the type of support, the
6 conditions of temperature and humidity, the ventilation and the type of microorganism in
7 question, what has been stated by Tsongas&Rioroan (2016) [41] has been followed; they
8 indicate that below a relative equilibrium humidity of 80% -85% the growth and proliferation
9 of most fungi is hindered.

10
11 Temperatures below 0°C could imply the start of freezing and expansion processes of the
12 water, swelling the material and causing irreversible damage to the plasterwork. In this regard,
13 a saturation modulus of less than 75% indicates that the ratio of open pores to total pores is low
14 enough so that the material does not have frost problems [42]. However, in the case study
15 presented, this lower limit temperature does not pose any risk since it will hardly be reached at
16 these latitudes.

17
18 The alterations suffered by the polychromies present on the plasterwork as a result of the loss
19 of cohesion due to the humidity of the plaster could also be taken into consideration [43]. In the
20 pictorial layers on plasterwork, generally made in tempera, the presence of humidity implies
21 the alteration of the binders. On the other hand, in the cases in which re-polichromies with oils
22 and waxes or gilded in later times are identified, the presence of humidity can prevent the
23 perspiration of the layers and, therefore, accelerate the degradation processes.

24
25 The craquelure or stiffening of the pictorial layers that cover a large part of the plasterwork
26 surface begins at low temperatures [27], favoring their partial detachments, being the range of
27 recommended temperatures for the correct preservation of the polychromies 10-24°C [8].

28 **1.3. Aim of this study**

29
30
31
32
33
34
35
36
37
38
39
40
41
42
43
44
45
46
47
48
49
50
51
52
53
54
55
56
57
58
59
60
61
62
63
64
65

1
2
3
4
5
6
7 The influence of environmental conditions on the conservation of plasterwork plays a main role.
8
9 Given this circumstance, the expected climate change in hot regions could lead to a variation in
10 conservation conditions. In this sense, it should be noted that in the scientific literature there
11 are few studies aimed at analyzing the impact of climate change on conservation risk, despite
12 the fact that estimates show that the impact may be significant [22,44]. It is assumed that, in
13 hot regions, the high temperatures expected throughout the 21st century may affect exterior
14 cladding. For this reason, the study of historical plasterwork of great heritage value located in
15 a warm region is addressed. The chosen case study is the Real Alcázar of Seville (RAS) and was
16 based on the following aspects: (i) the annual monitoring of the environmental parameters T
17 and RH, (ii) the estimation of hourly values in future scenarios using artificial intelligence and
18 (iii) the use of the threshold values for the conservation of plasterwork defined in the literature.
19
20
21
22
23
24
25
26
27
28
29
30
31
32

33 **2. METHODOLOGY**

34
35
36
37
38 The methodological framework of this research is summarized in Fig. 2. As it can be seen, in
39 this study a measurement process was carried out of an external point of the case study, while
40 the external climate of the city was also monitored. Through these two approaches, the
41 estimates for the years 2050 and 2080 were obtained using different methods. All these sets of
42 environmental data were analyzed to evaluate the conservation risk of the historic plasterwork
43 of the RAS.
44
45
46
47
48
49
50
51
52
53
54
55
56
57
58
59
60
61
62
63
64
65

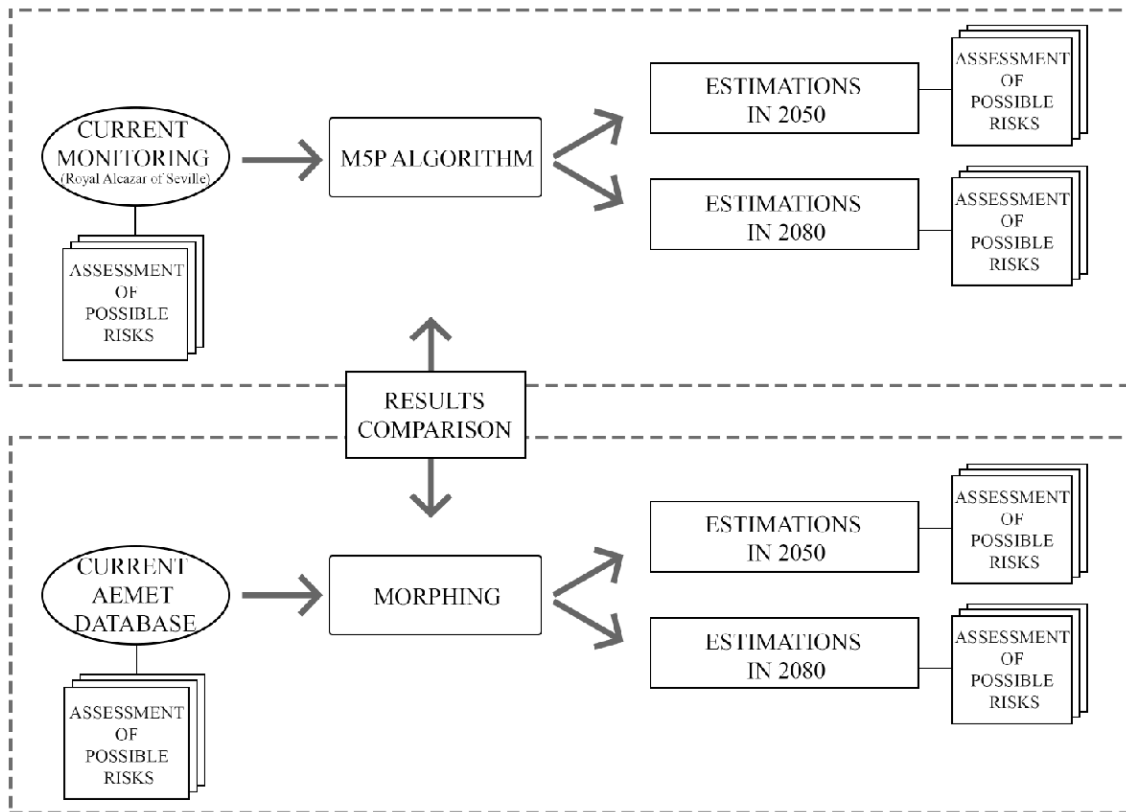

Fig. 2. Flowchart of the steps followed in the study.

2.1 Case study: The Palace of Pedro I (Real Alcázar of Seville)

The RAS was considered an Asset of Cultural Interest by the Spanish state in 1831¹ and declared a World Heritage Site by UNESCO in 1987². The complex is composed by different buildings built between the 10th and 18th centuries, among which the Palace of Pedro I (1356-1366) stands out [45] for the compositional richness of its decorations such as plasterwork [2] [3], ceramic tiles [4] [49] and carpentry [50,51] (Fig. 3).

¹ RI-51-0001067 according to Law 16/1985, of June 25, on Spanish Historical Heritage

² <http://whc.unesco.org/en/list/383> (Viewed in March 2021)



Fig. 3 Images of the Palace of Pedro I: (A and B) Courtyard of the Dolls, (C) Bedroom of the Moorish Kings, (D) Courtyard of the Maidens.

Environmental conditions have a direct influence on the conservation of materials, favoring degradation processes over time. In the case of plasterworks, the alterations are mainly manifested on the surface, which is the physically and mechanically weakest area, favoring deterioration, loss of material and the appearance of stains (Fig. 4). Moisture defects are caused by physical mechanisms, causing bulging, blisters, detachments, stains and even erosions and fissures. But moisture, normally infiltrated, develops a synergistic effect with chemical agents that gives rise to the appearance of injuries, as it can dissolve certain soluble salts contained in plasterwork, transporting them to the outside, evaporating the water in contact with the lower vapor pressure atmosphere and recrystallizing the salts, leading to efflorescence and crypto-efflorescence [29].



Fig. 4 Deterioration in RAS plasterwork: water seepage (A), direct action of rain (B), detachment after oxidation of the metallic element (C), disintegration of the material (D).

This work aims to establish a relationship between the environmental parameters (T - RH) and the preservation of historical plasterwork that allows to easily detect if the conditions of conservation for the material are optimal or not, and to know how they have influenced, and how they are influencing the process of degradation of the plasterwork. The study focuses on the Courtyard of the Maidens - the ground floor of the Palace of Pedro I- because there is the largest sample of plasterwork and the oldest since some are from the 14th century [52]. A complete characterization of these plasterworks and their polychromies could be found on previous works by other authors [46,47].

Additionally, the preventive conservation of the heritage is evaluated in future climate scenarios for the specific case of study and, once the climate model has been calibrated, it could be extrapolated to analogous climates to evaluate the long-term projection of the climatological conditions and its possible influence on the conservation of the plasterwork.

1 The control and regulation of environmental parameters within a reference interval around
2 average values or typical seasonal cycles of the historical RAS climate will reduce the risk of
3 physical-mechanical damage and will also allow to establish mitigation actions.
4

5
6
7 On the ground floor of the Palace, the interior areas are not physically closed by carpentry or
8 locksmiths and are permanently open; there are large access arches that allow transit between
9 different rooms, as well as between these and the outdoor spaces.
10
11

12
13
14 In this way, two areas according to exposure to environmental conditions could be defined. An
15 area that includes those plasterworks that receive direct incidence of solar radiation has been
16 considered (yellow zone) (Fig. 5-A), and another zone with those plasterworks not exposed to
17 direct sunlight and with a higher relative humidity (red zone), being the most representative
18 and unfavorable case in terms of the environmental parameters (Fig. 5-B).
19
20
21
22
23
24

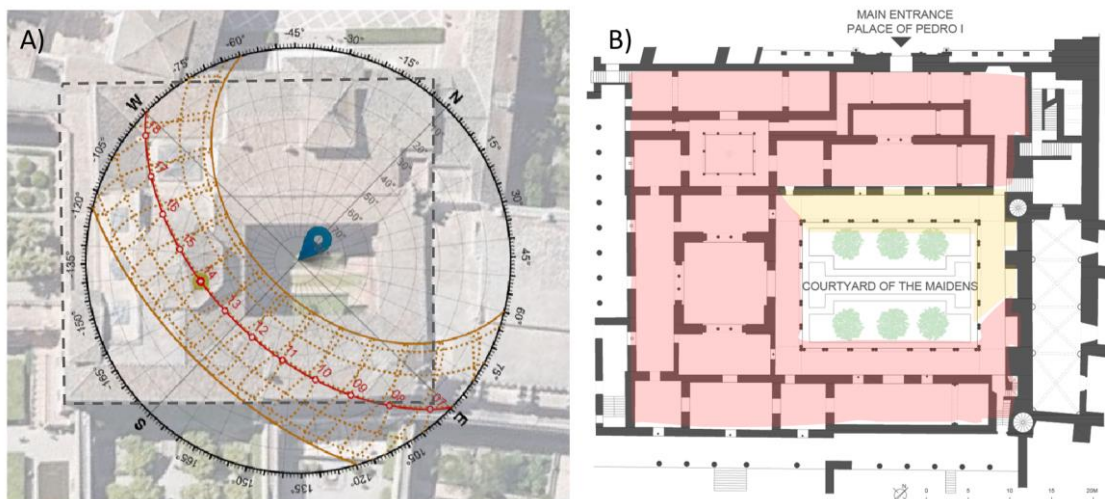

25
26
27
28
29
30
31
32
33
34
35
36
37
38
39
40
41
42
43
44 **Fig. 5** A) Solar path on 03/20/2020 in the geographical coordinates corresponding to the Palace of Pedro I
45 (Retrieved from <https://www.sunearthtools.com/>) B) Two different zones on the ground floor of the Pedro I Palace
46 according to sunlight.
47
48

49
50 Additionally, it has been possible to verify that the humidity and temperature values measured
51 in the interior rooms of the Palace of Pedro I [36] are very similar to those obtained in the
52 southeast gallery of the Courtyard of the Maidens (exterior) because this area does not receive
53 the direct incidence of solar radiation (Fig. 5-A).
54
55
56
57
58
59
60
61
62
63
64
65

1
2
3
4
5
6
7
8
9
10 **2.2. Measurement procedure**
11

12
13 To determine ambient temperature and relative humidity conditions, a Lascar
14 thermohygrometer, model EL-USB 2 LCD with two recording channels, within the range -35°C
15 to 80°C and 0% RH to 100% RH, with a resolution of $\pm 0.5^\circ\text{C}$ and $\pm 3\%$ RH was used.
16
17

18
19 In this case, the measurements have been carried out over a period of one year, at
20
21 uninterrupted one-hour intervals from March 2020 to February 2021 with a thermo-hygrometer
22
23 placed in the southeast gallery of the Courtyard of the Maidens (Fig. 6).
24
25

26
27 The outdoor measurements were obtained through the AEMET (State Meteorological Agency
28
29 in Spain). The meteorological station used was the one located in Seville. This meteorological
30
31 station is equipped with a VAISALA HMP45D probe with a measuring range from -40 to 60°C
32
33 and -0.8 to 100% RH, and an accuracy of $\pm 0.2^\circ\text{C}$ and $\pm 2\%$ RH. The measurement data obtained
34
35
36 are also from one-hour intervals.
37
38

39
40 To determine the interval of variation of RH by months, the average of the minimum and
41
42 maximum daily humidities has been calculated and the monthly arithmetic means of these
43
44 values have been obtained. These data have been studied following the indications of the UNE-
45
46
47 EN 15757: 2011 standard[9].
48
49
50
51
52
53
54
55
56
57
58
59
60
61
62
63
64
65

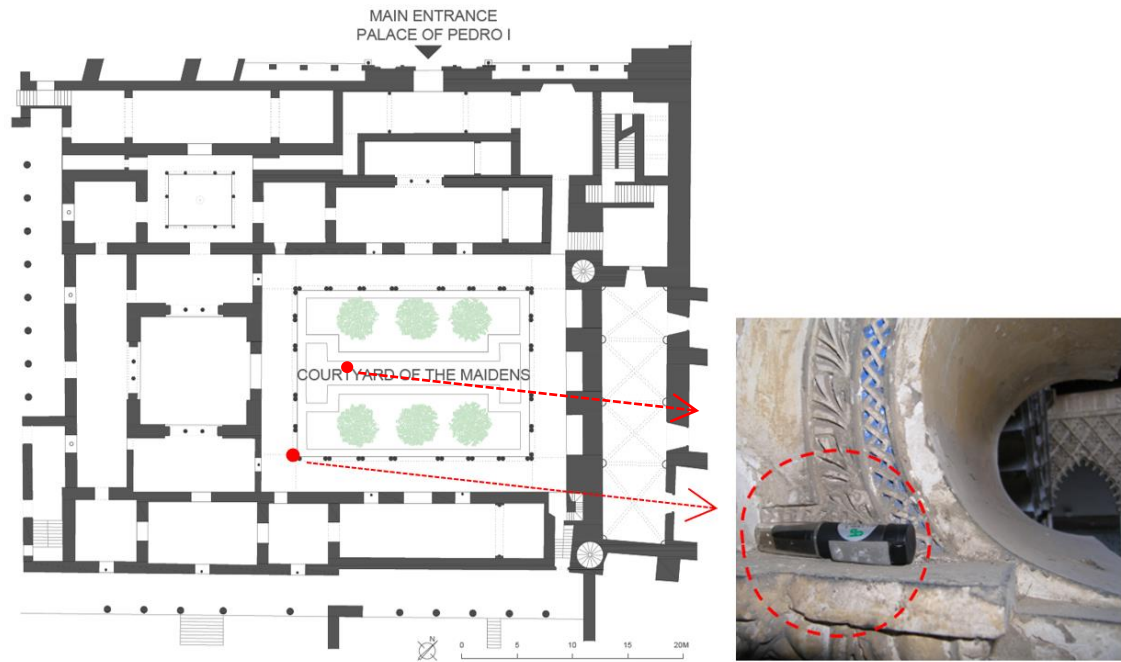

Fig. 6 Location of the monitoring equipment on the ground floor of the Pedro I Palace.

2.3. Obtaining future climate data

According to the data obtained during the annual monitoring, two approaches have been carried out to obtain future time series: (i) estimation of future outdoor climate data through the EPW morphing process of the climate zone of the case of study, and (ii) the estimation of the time series of the interior point through the application of data mining algorithms.

2.3.1. Morphing from the EPW of the climate zone of the case study

The first of them was based on the climatic files provided by the Spanish Technical Building Code (CTE)[53] for the climate zone of Seville, Csa (Mediterranean) according to Köppen – Geiger classification [54]. In the first place, T and RH data resulting from the monitoring have been entered in the Seville climate archive to be able to carry out the evaluation of future scenarios. Secondly, T and RH data measured outdoors have been compared with those existing in the CTE to see if it is feasible to establish considerations, not only in the case of study but also in plasterwork in similar "subtropical dry-summer" climates. The calibration criteria of the Federal Energy Management Program (FEMP)[55], ASHRAE GUIDELINE Standard 14-2002

[56], [57] and the International Performance Measurement and Verification Protocol (IPMVP) [58] have been followed. This validation process makes it possible to verify if the results of the estimations for the climate zone of Seville are related to the real values monitored with a margin of error. For this, the following formulas are used:

$$MBE = \frac{\sum_{i=1}^n (m_i - s_i)}{n} \quad (1)$$

$$MBE = \frac{\sum_{i=1}^n (m_i - s_i)}{n} \quad (2)$$

$$NMBE = \frac{1}{\bar{m}} \cdot \frac{\sum_{i=1}^n (m_i - s_i)}{n-p} \quad (3)$$

In order to scale the results of the Mean Bias Error (MBE) (Equation 1), Normalized Mean Bias Error (NMBE) is used by dividing MBE by the mean of measured values (\bar{m}), giving the global difference between the real values and the predicted ones (Equation 2); In these equations m_i is the measured value, s_i is the simulated one and n the number of measured data points. The Coefficient of Variation of the Root Mean Square Error CV (RMSE) measures the variability of the errors between measured and simulated values (Equation 3).

The limit values associated with these parameters vary depending on whether they are hourly or monthly. Considering that the environmental variables are hourly, the limit values are between -10% and 10% in NMBE and less than 30% in CV (RMSE) [56,57].

To estimate future climate scenarios in the climate zone, the CCWorldWeatherGen tool from the UK Met Office Hadley Center Coupled Model 3 HadCM3 has been used. Through a morphing process, this tool generates weather files adapted to climate change from any location in the world and creates files compatible with most building performance simulation programs [59]. The morphing of the climate files has been carried out for scenario A2 of greenhouse gas emissions according to the IPCC [60], resulting in climate scenario files for years 2050 and 2080.

2.3.2. Estimation of future time series of the case study

The data mining approach of this study was performed using the M5P algorithm. This algorithm allows estimating the time series for the years 2050 and 2080 in the measured interior point of the case study. The M5P algorithm (also known as M5') is an evolution of the Classification and regression tree (CART) [61,62]. Unlike CART, M5P combines decision trees with multivariate regression; a decision tree is built following the same inverted tree structure offered by CART, but a multiple linear regression (MLR) model is fitted on each sheet (Equation 4). Therefore, the algorithm works by developing an MLR model in each subregion (Fig. 7). In the process of developing the M5P algorithm tree, instead of maximizing the information gain, the internal variation of the subsets for the class values of each branch is minimized. Once the model is built, pruning reduces overfitting. The advantages of the models generated by this algorithm are that they efficiently handle large amounts of numerical variables and are robust in the absence of values in the instances of the analyzed dataset [63,64]. Thus, its use for the characterization of different aspects of buildings has increased in recent years [65,66].

$$\hat{Y}_{MLR} = \beta_0 + \sum_{i=1}^p (\beta_i x_i) + \varepsilon \quad (4)$$

Where β_0 is the independent term, β_i are the regression coefficients, x_i are the predictor variables, and ε is the error.

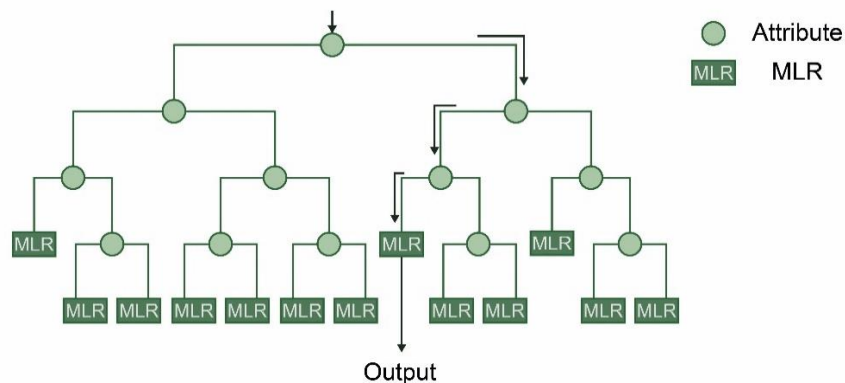

Fig. 7. Scheme of an M5P model.

The approach designed had a configuration of 6 input variables corresponding to the hourly values of temperature, relative humidity, dew point temperature, horizontal infrared radiation intensity, global horizontal radiation, and direction normal solar irradiance, diffuse horizontal solar irradiance of the time series of the outer point of Seville. The output variables correspond to the relative humidity and the temperature at the interior point of the case study. For each output variable a different M5P was designed.

The training of each M5P model was carried out using the data from the current scenario. Once the models were trained, time series of the years 2050 and 2080 were estimated. It is worth noting that the M5P models were validated using the coefficient of determination and the MBE index as statistical parameters.

3. RESULTS AND DISCUSSION

3.1 Thermo-hygrometric conditions of the Palace of Pedro I

The results obtained from the monitoring carried out between March 2020 and February 2021 in the southeast gallery of the Courtyard of the Maidens are shown in Fig. 8 and table 1:

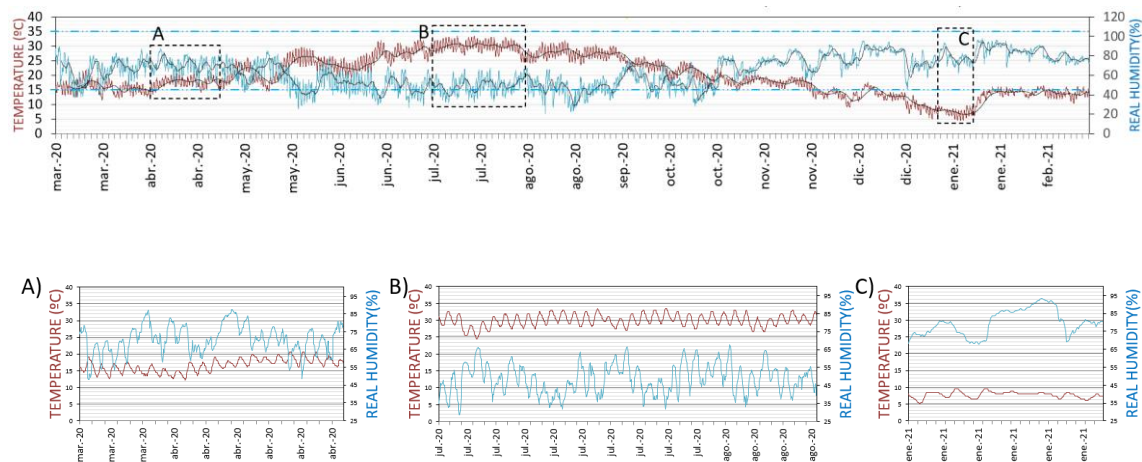

Fig. 8 Environmental conditions in the southeast corner of the Courtyard of the Maidens from March 2020 to February 2021.

The measurement of the T and RH parameters is relevant mainly for the study of the fluctuations and thermal jumps that may occur during the day-night hours or during the different seasons of the year. In this regard, it is observed that the most pronounced thermal jumps between day and night hours do not exceed 5°C (July and August), a fact that -by itself-

does not represent any risk in terms of material expansion. Finally, a high RH in winter is recorded and must be controlled with adequate ventilation, although it is within the acceptable range for the correct preservation of plasterwork.

Table 1. Summary of environmental parameters from 01/03 /2020 to 28 / 02/2021.

Months	RELATIVE HUMIDITY (%)					TEMPERATURE (° C)				
	Min. Values registered		Max. values registered		Δ (max-min)	Min. Values registered		Max. values registered		Δ (max-min)
	Average	SD	Average	SD		Average	SD	Average	SD	
Feb 20	55.3	11,001	73.8	9,454	18.5	14	1,319	18.1	1,577	4.1
Ap. 20	60.6	6,672	77.7	4,79	17.1	15.7	1,534	19.2	1,558	3.5
May 20	43.3	10,818	64.1	9,947	20.8	21.3	2,337	26.1	2,832	4.8
Jun 20	41.4	5,608	62	7,87	20.6	22.3	2,434	27.3	2,314	5
Jul. 20	38	5,877	56	7,43	18	27.6	1,448	31.8	1,328	4.2
Aug. 20	38	8,637	56.5	7,966	18.5	26.3	1,675	30.5	1,581	4.2
Sept. 20	44.1	9,493	58.3	8,287	14.2	24	1.9	27.4	2,105	3.4
Oct. 20	49.3	12,985	63.1	11,674	13.8	18.1	1,996	21.3	2,136	3.2
Nov. 20	70	8,459	78.6	7,134	8.6	15.6	1,964	17.9	1,965	2.3
Dec. 20	74.2	10,822	84.4	8,133	10.2	11.4	2,366	13.7	1,935	2.3
Jan. 21	75.2	9,545	86.1	8,141	10.9	8.6	3,493	11.2	3,093	2.6
Feb. 21	77.4	5,562	83.1	5,129	5.7	12.9	1,127	15.1	0,854	2.2

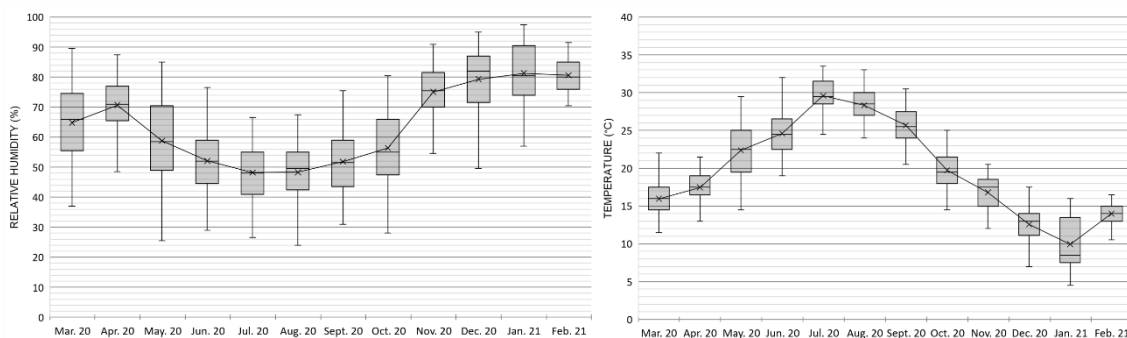
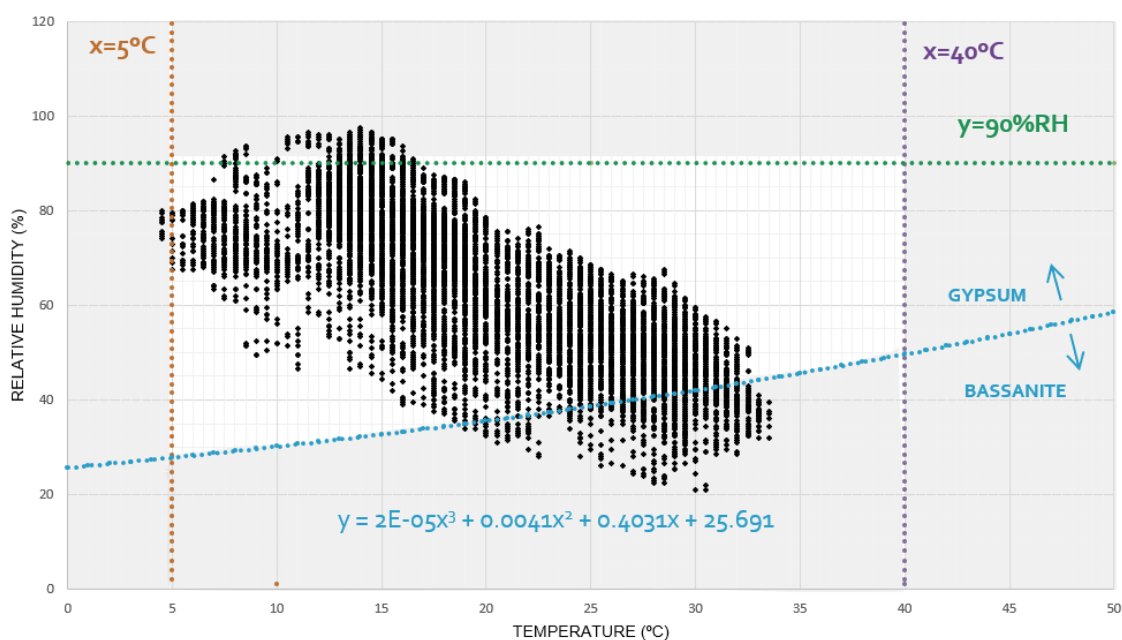

Fig. 9 Graphical representation of ambient condition (T and RH) from 01/03 /2020 to 28 / 02/2021.

From a detailed analysis of the measurements obtained (Table 1 and Fig 9), the risk due to high RH is concentrated from November to February, both inclusive; being January the most unfavorable month since 27.02% of the measurements recorded during that month exceed the limit of 90% RH. Likewise, the risk of dehydration of the gypsum and transformation into bassanite ($\text{CaSO}_4 \cdot 1/2\text{H}_2\text{O}$) occurs from May to October, both inclusive; being July and August

1 the most critical months for such purposes. It is worth to highlight that a 56.71% of the
2 measurements recorded in the year remain below the limit established in the matrix (Fig. 10).
3

4
5
6
7 The data obtained correspond to a total of 8,760 measurements, of which only 11.76% are
8 outside the limits established in the matrix that relates thermo-hygrometric conditions with the
9 mineralogical phases of calcium sulfate, depending on their degree of hydration.
10
11
12
13



14
15
16
17
18
19
20
21
22
23
24
25
26
27
28
29
30
31
32
33
34
35
36
37 **Fig. 10** Dispersion graph of the measurements from 01/03 /2020 to 28 / 02/2021 at the southeast corner of the
38 Courtyard of the Maidens.

39
40
41 Regarding the type of risk detected, it can be seen in Fig. 10 how it is mainly distinguished
42 between risk due to internal structural transformations (associated with the summer months)
43 and risk due to high RH (associated with the winter months). The 7.95% of the hourly records
44 correspond to measurements that are below the curve established by Winkler& Wilhelm [31] ,
45 while the risk due to a high RH corresponds to 3.65% and the risk due to a low T corresponds to
46 only 10 observations throughout the year, so the current climatic conditions in the Courtyard of
47 the Maidens are favorable in this sense.
48
49
50
51
52
53
54
55
56
57
58
59
60
61
62
63
64
65

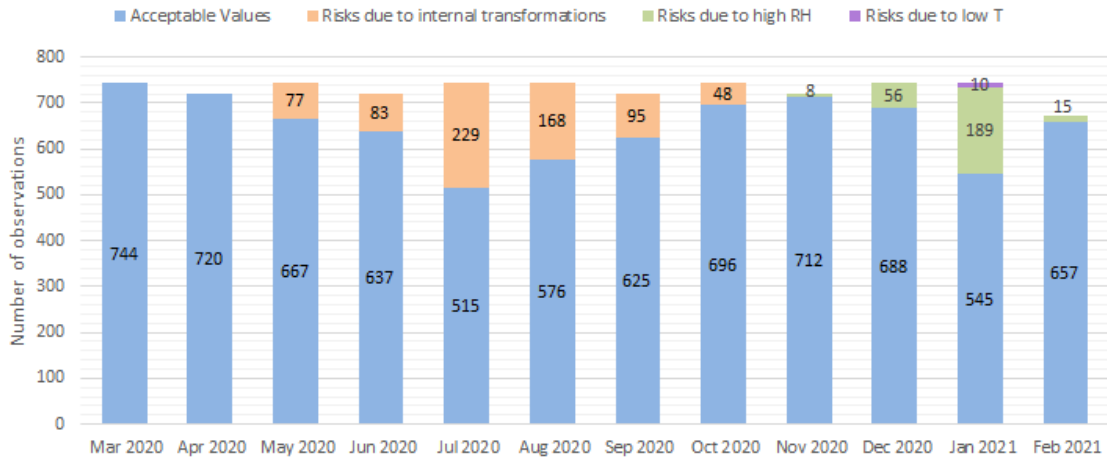

Fig. 11 Monthly representation of the hourly measurements obtained in the Courtyard of the Maidens from March 2020 to February 2021.

However, the results obtained from monitoring the climate of the city of Seville show different trends in conservation risks (Fig. 11). As it can be seen, although the most prominent risks are once again that of internal transformations in summer and high RH in winter, there is a greater number of observations that remain within these risks. Thus, the observations at risk of internal transformations correspond to values between 348 and 360 in July and August, while in the Courtyard of the Maidens the values were 229 and 168, respectively. Likewise, it was also detected how the risk due to high RH extends to a greater number of months than in the case of the Courtyard of the Maidens and with a significantly higher number of observations.

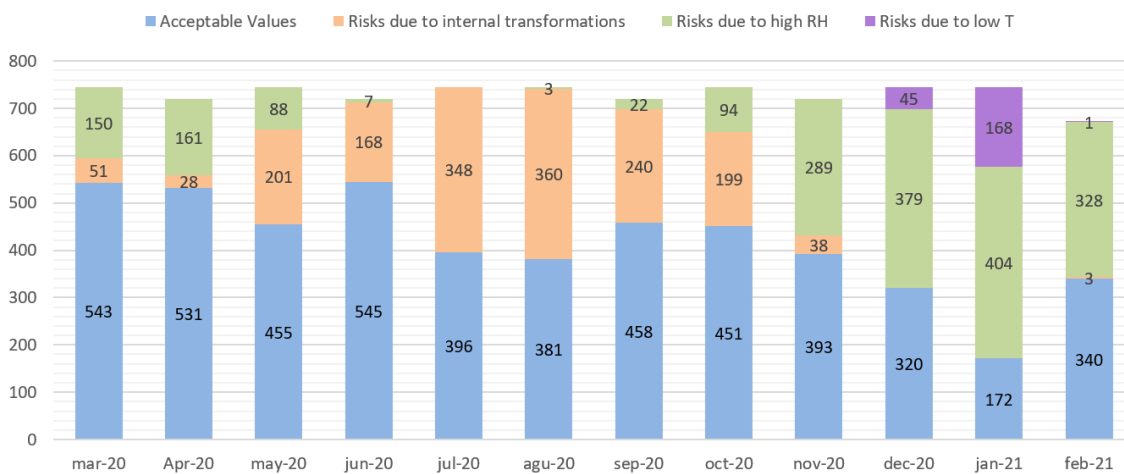

Fig. 12 Monthly representation of the hourly measurements obtained in Seville from March 2020 to February 2021.

Therefore, significant variations are detected in the results obtained with the two approaches.

While the approach to the analysis of the Courtyard of the Maidens point (with a clear microclimate) presents less severe conditions for the conservation of plasterwork, outside the conditions would be different, presenting a greater risk due to the climate in these elements. Likewise, the variability detected between the two approaches shows the great variation that the analysis approaches of the influence of climate can present on the conservation of plasterwork. Thus, the use of a joint approach to the outdoor climate and microclimates in this type of case study allows us to show a broader perspective of the risk of conservation of plasterwork.

3.2 Calibration of outdoor measurements. The climate file of Seville.

Despite the possible risks detected in the current scenario, climate change can generate a change in the conservation conditions of plasterwork. For that, the future time series for the two previously validated approaches used were estimated in this study. In the case of the outdoor climate approach, T and RH parameters measured during the outdoor monitoring are compared with T and RH data extracted from the CTE for the climate zone of Seville Csa (Mediterranean). As the environmental variables analyzed are hourly, the limit values are between -10% and 10% in NMBE and less than 30% in CV (RMSE). According to Table 2, it is detected that the CV (RMSE) values are within the established error limits. However, it is detected that T is slightly higher (0.88%) than the limits in the NMBE and in matters related to RH the value exceeds the limit in the NMBE by 6.40% (Table 2). From these results we can establish the following considerations:

In the first place, considering that a measurement is being compared under specific environmental conditions with a typical meteorological year according to the criteria established in the CTE and based on the available meteorological stations, the level of approximation is good, especially if we consider the CV (RMSE).

Table 2. Calibration of measured data in RAS compared to CTE. Limit values according to ASHRAE Guideline14.

Variable	NMBE [%]		CV (RMSE) [%]	
	Obtained values	Limit values	Obtained values	Limit values
Temperature (T)	11.03	± 10	25.34	30
Relative humidity (RH)	15.52	± 10	27.08	30

Therefore, to make predictions for climate scenarios on the case study, it is necessary to use the actual measured values of T and RH. However, in order to establish considerations on similar Csa dry-summer subtropical or Mediterranean climates, we can consider the approximation to the real measurements as acceptable, recommending the verification of the specific microclimatic conditions using procedures similar to the one used.

In the case of the interior point approach, future estimates were obtained by M5P algorithm. Table 3 shows the values associated with each M5P model, while Fig. 13 shows the cloud of points between the actual and estimated values of the training and validation phase. As it can be seen, the coefficient of determination ranged between 74% and 87%, while the mean error ranged between 2.6°C and 8% RH in each variable. The estimates were more limited in the RH variable in a similar way to that detected in other studies for estimating future time series of RH [14]. In any case, the results can be considered valid to have a knowledge of the future time series expected in the addressed case study.

Table 3. Performance obtained by the M5P models in the training and validation phase.

Approach	Output variable	Determination coefficient (R ₂)	MBE
M5P 1	Temperature (T)	86.53%	2.6
M5P 2	Relative Humidity (RH)	74.93%	8.0

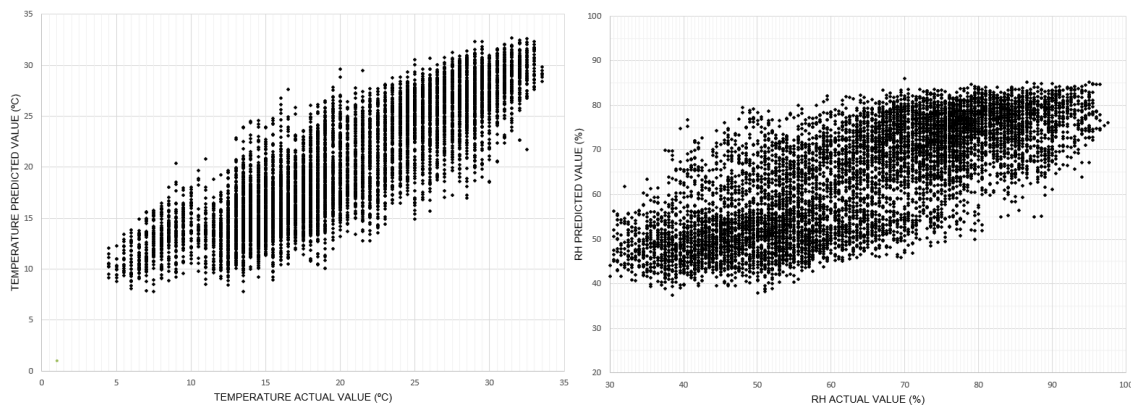

1
2
3
4
5
6
7
8
9
10 **Fig. 13** Point clouds between the actual and estimated values in the training and validation phase.
11
12

13 **3.3. Forecast of ambient temperature and humidity conditions in 2050 and 2080**

14 Estimates of the time series in 2050 and 2080 of the two approaches make it possible to analyze
15 the conservation risk in plasterwork with respect to the thresholds used in this study (Fig. 14).
16 It can be seen how the behavior of the time series are different in both point clouds. While in
17 the outdoor climate represents how the data are characterized by RH close to zero, in the case
18 of the courtyard, higher lower values are detected. This can be seen more clearly with the values
19 of the quartiles of the distributions. In the case of the exterior point in 2050, the minimum value
20 of RH was 1% in 2050 and 2080, while in the Courtyard of the Maidens it was 19% in 2050 and
21 13% in 2080. Likewise, the quartiles show higher values in the Courtyard of the Maidens: (i) the
22 first quartile (Q1) of the outer point obtained RH values of 34% in 2050 and 28% in 2080, while
23 the inner point of the case study obtained values of 48% in 2050 and 45% in 2080; (i) the second
24 quartile (Q2) of the outer point obtained RH values of 49% in 2050 and 45% in 2080, while the
25 inner point of the study case obtained values of 58% in 2050 and 54% in 2080; and (iii) the third
26 quartile (Q3) of the outer point obtained RH values of 62% in 2050 and 60% in 2080, while the
27 inner point of the study case obtained values of 71.5% in 2050 and 68.5 % in 2080.
28
29
30
31
32
33
34
35
36
37
38
39
40
41
42
43
44
45
46
47
48
49
50
51
52
53
54
55
56
57
58
59
60
61
62
63
64
65

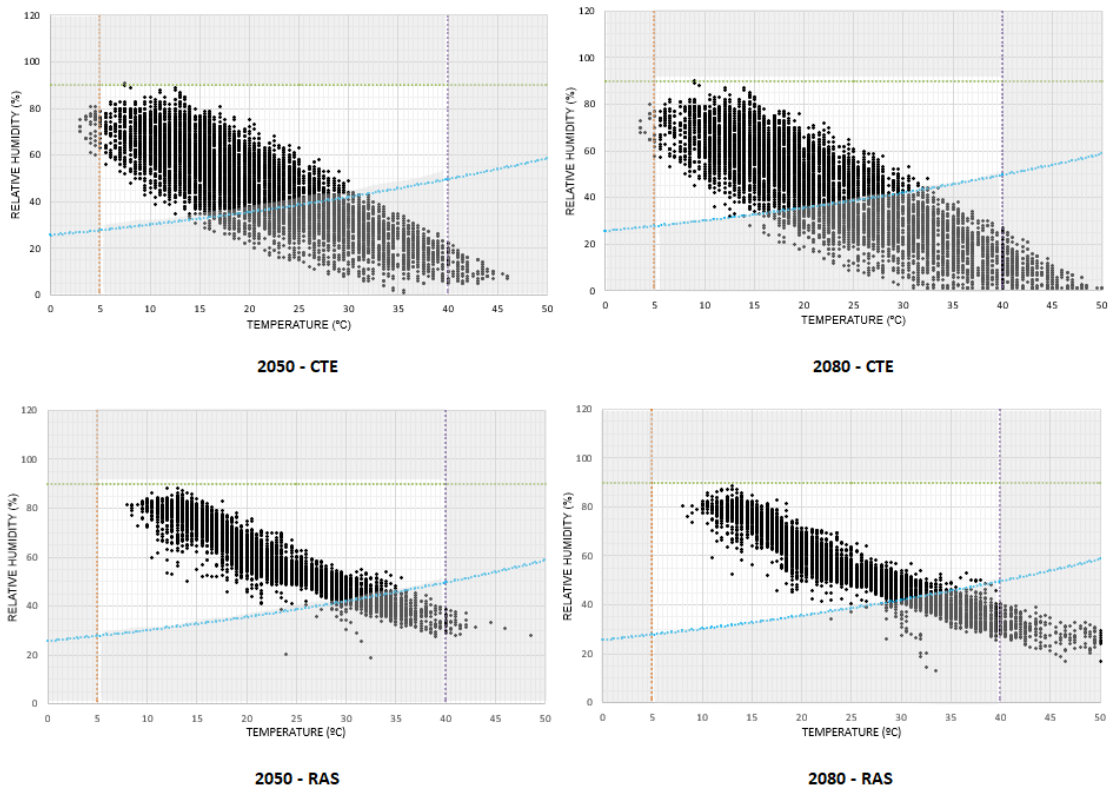

Fig. 14 Estimation of the climatic conditions of Seville (according to CTE) and RAS (own data in 2020 and estimation in 2050 and 2080 using M5P algorithm).

These variations in the time series distributions imply a different risk assessment in each combination of approach and year (Fig. 14), following the trends detected in the current scenario. Thus, the risk due to a very low RH indicated in Fig. 15 is corroborated. The results obtained by morphing the EPW reveal that the months with the lowest RH and highest ambient T will be August, September and October, leaving 99.58% of the estimates foreseen for the month of September 2080, below the optimal RH and at high ambient T. This risk due to high T combined with low RH is also appreciated in the estimation using the M5P but less accentuated and mainly framed in the months of June, July and August.

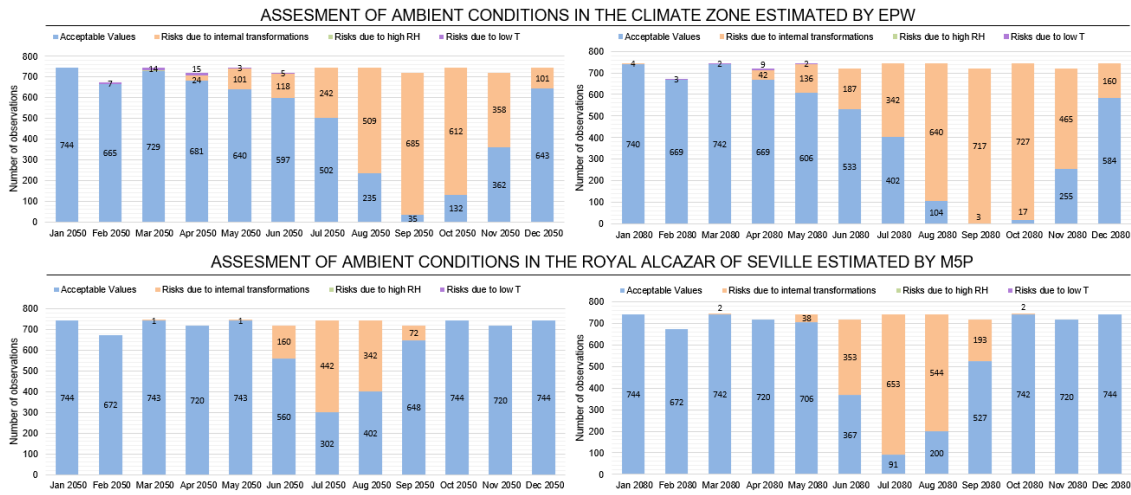

Fig. 15. Monthly representation of the risks obtained with the two approaches in future scenarios.

Thus, the results obtained indicate that the environmental conditions of the Mediterranean climate will tend towards a considerable increase in T that will be accompanied by lower RH, favoring the dehydration of materials such as plaster and the mechanical weakening of coatings in general. This trend is less pronounced in the case of the estimates obtained for the RAS because, although there is a slight increase in T, RH does not drop by 20%, which may be positive for the preservation of the plasterwork, as it would indicate that probably dehydration of the material occurs accompanied by its subsequent rehydration, maintaining mechanical performance[32].

In addition, the estimates obtained indicate that, over time, the appearance of humidity stains, the softening of the surface, the appearance of mold or the cracking of the polychromes of the RAS plasterwork, mainly caused by high HR, would be reduced. notably.

In any case, the differences obtained between the two approaches show the great variability that future estimates may obtain when evaluating the conservation risk in plasterwork. This aspect may mean that considering a single approach does not allow all possible behavioral scenarios to be encompassed. Thus, the joint analysis with climatic data in free field and with existing microclimate data in the case of study allows to know in detail the possible future ambient conditions. In this sense, the results obtained in free field could be representative for

1 the spaces in the study case that have plasterwork and do not have their own microclimate,
2 such as the facade of the Palace of Pedro I. However, environments with a more unique
3 microclimate, such as the Courtyard of the Maidens, may have different variations in the level
4 of conservation.
5
6
7
8
9

10 **4. CONCLUSIONS**

11 This paper highlights that the impact of climate change on architectural heritage must be
12 considered in the long-term management of the RAS. Plasterwork executed in the 14th century
13 may not withstand future extreme climate conditions and risks associated with climate change
14 should, therefore, be identified and quantified to facilitate relevant preservation measures. A
15 long-term strategy to adapt to climate change must be based on risk assessment, adaptation
16 measures, and monitoring. In this way, advanced simulations can be used to predict the future
17 ambient conditions and its effect not only on historic buildings but also on plasterwork.
18 However, due to the high degree of uncertainty in simulations, this approach is not sufficient.
19
20
21
22
23
24
25
26
27
28
29
30
31

32 This study establishes limits within a matrix that indicate the optimal conditions for better
33 preservation of historical plasterwork. According to the obtained results based on the analysis
34 of the environmental conditions (RH and T) during a period of one year with a frequency of 1h
35 has allowed to verify that less than 12% of the measurements (n: 8760) exceed the limits of that
36 matrix, not being a long-term exposure and, therefore, not assuming a risk for the preservation
37 of the material.
38
39
40
41
42
43
44
45
46
47
48
49
50
51

52 The measurements have been compared with those collected by the CTE (B4) and the AEMET
53 and, by calculating the quadratic error, it has been possible to predict that the environmental
54 conditions that will occur in the Pedro I Palace in future -years 2050 and 2080 - will be, a priori,
55 favorable for the preservation of historical plasterwork. The data allow us to foresee a greater
56
57
58
59
60
61
62
63
64
65

1
2
3
4
5
6
7
8
9
10
11
12
13
14
15
16
17
18
19
20
21
22
23
24
25
26
27
28
29
30
31
32
33
34
35
36
37
38
39
40
41
42
43
44
45
46
47
48
49
50
51
52
53
54
55
56
57
58
59
60
61
62
63
64
65

number of periods of high temperatures and low relative humidity; however, it has been estimated that the mechanical performance of the material would not be significantly affected by dehydration processes due to they are not long-terms periods. The long-term climate data matrix obtained makes it possible to clearly establish that the climatic conditions inside the building are significantly more favorable than those outside, with a lower risk of alteration due to dehydration of the plaster.

Although the climatic conditions are not particularly severe in their impact on plasterwork, there is a clear trend towards more unfavorable conditions in certain periods of the year, which means that maintenance and preservation measures are planned for both, plasterwork and plaster mortar coatings of relevant buildings, in dry-summer subtropical climate.

The methodological process developed, which is based on periodical measurements which have been compared with data collected by the CTE (B4) and the AEMET, in order to establish a projection of long-term material performance may applied in the conservation intervention of the RAS and even in other similar buildings located in dry-summer subtropical climate. Results allow to establish an effective maintenance program that implies detailed review of each element, periodic reports of the controls and actions carried out and, specific corrective actions to fix mobile pieces or repair damage caused by external agents. This maintenance program and the meteorological data obtained in this work will also determine priority criteria for conservation and restoration interventions.

5. Disclosure statement

The authors have no conflicts of interest to declare.

6. Author contributions

All authors had full access to all the data and take responsibility for the integrity and the accuracy of the data analysis.

7. ACKNOWLEDGEMENTS

This research has been carried out thanks to the financing of the project "DEVELOPMENT AND EVALUATION OF DURABILITY MODELS AND PREVENTIVE CONSERVATION OF DECORATIVE ELEMENTS FROM THE HISTORICAL PLASTERS OF THE ROYAL ALCÁZAR DE SEVILLA" (PGC2018-093470-B-I00) by the Ministry of Science, Innovation and Universities of the Government of Spain and the financing received from the VI PPIT-2021-I.3 from the University of Seville.

The authors wish to thank the collaboration of the Board of Trustees of the Real Alcázar of Seville for the facilities provided to achieve visual inspection and measurement of environmental parameters.

8. REFERENCES

- [1] E. Lucchi, Review of preventive conservation in museum buildings, *J. Cult. Herit.* 29 (2018) 180–193. <https://doi.org/10.1016/j.culher.2017.09.003>.
- [2] D. Camuffo, *Microclimate for Cultural Heritage: Conservation, Restoration, and Maintenance of Indoor and Outdoor Monuments*, Elsevier, 2019.
- [3] I. Cook, R. Johnston, K. Selby, Climate Change and Cultural Heritage: A Landscape Vulnerability Framework, *J. Isl. Coast. Archaeol.* (2019). <https://doi.org/10.1080/15564894.2019.1605430>.
- [4] C. Ferreira, J. Barreiras, A. Silva, J. de Brito, I.S. Dias, I. Flores-Colen, Impact of environmental exposure conditions on the maintenance of facades' claddings, *Buildings*. 11 (2021). <https://doi.org/10.3390/buildings11040138>.
- [5] V. Costanzo, K. Fabbri, E. Schito, M. Pretelli, L. Marletta, Microclimate monitoring and conservation issues of a Baroque church in Italy: a risk assessment analysis, *Build. Res. Inf.* 0 (2021) 1–19. <https://doi.org/10.1080/09613218.2021.1899797>.
- [6] S.P. Corgnati, M. Filippi, Assessment of thermo-hygrometric quality in museums: Method and in-field application to the "Duccio di Buoninsegna" exhibition at Santa Maria della Scala (Siena, Italy), *J. Cult. Herit.* 11 (2010) 345–349. <https://doi.org/10.1016/j.culher.2009.05.003>.
- [7] M. Zarzo, A. Fernández-Navajas, F.J. García-Diego, Long-term monitoring of fresco paintings in the cathedral of Valencia (Spain) through humidity and temperature sensors in various locations for preventive conservation, *Sensors*. 11 (2011) 8685–8710. <https://doi.org/10.3390/s110908685>.
- [8] N. Italiana, UNI 10829. Works of art of historical importance. Ambient conditions for the conservation. Measurement and analysis. [Beni di interesse storico e artistico. Condizioni ambientali di conservazione. Misurazione ed analisi.], (1999) 1–24.

- 1
2
3
4
5
6
7
8
9
10
11
12
13
14
15
16
17
18
19
20
21
22
23
24
25
26
27
28
29
30
31
32
33
34
35
36
37
38
39
40
41
42
43
44
45
46
47
48
49
50
51
52
53
54
55
56
57
58
59
60
61
62
63
64
65
- [9] A.E. de N. UNE, UNE-EN 15757: Conservation of Cultural Property - Specifications for temperature and relative humidity to limit climate-induced mechanical damage in organic hygroscopic materials, (2011).
 - [10] Ansi/Ashrae, ANSI/ASHRAE 55:2004 Thermal Environmental Conditions for Human Occupancy, Ashrae. (2004) 30.
 - [11] PAS 198:2012 - Specification for managing environmental conditions for cultural collections – BSI British Standards, (n.d.). <http://shop.bsigroup.com/ProductDetail/?pid=00000000030219669>.
 - [12] UNE-EN-15759-1, Conservation of cultural property. Indoor climate. Part 1: Guidelines for heating churches, chapels and other places of worship, (2012).
 - [13] C. Bonacina, P. Baggio, F. Cappelletti, P. Romagnoni, A.G. Stevan, The Scrovegni Chapel: The results of over 20 years of indoor climate monitoring, *Energy Build.* 95 (2015) 144–152. <https://doi.org/10.1016/j.enbuild.2014.12.018>.
 - [14] D. Bienvenido-Huertas, M. León-Muñoz, J.J. Martín-del-Río, C. Rubio-Bellido, Analysis of climate change impact on the preservation of heritage elements in historic buildings with a deficient indoor microclimate in warm regions, *Build. Environ.* 200 (2021) 107959. <https://doi.org/10.1016/j.buildenv.2021.107959>.
 - [15] G. Zonno, R. Aguilar, R. Boroschek, P.B. Lourenço, Analysis of the long and short-term effects of temperature and humidity on the structural properties of adobe buildings using continuous monitoring, *Eng. Struct.* 196 (2019) 109299. <https://doi.org/10.1016/j.engstruct.2019.109299>.
 - [16] R.P. Kramer, M.P.E. Maas, M.H.J. Martens, A.W.M. van Schijndel, H.L. Schellen, Energy conservation in museums using different setpoint strategies: A case study for a state-of-the-art museum using building simulations, *Appl. Energy.* 158 (2015) 446–458. <https://doi.org/10.1016/j.apenergy.2015.08.044>.
 - [17] M. Napp, T. Kalamees, Energy use and indoor climate of conservation heating, dehumidification and adaptive ventilation for the climate control of a mediaeval church in a cold climate, *Energy Build.* 108 (2015) 61–71. <https://doi.org/10.1016/j.enbuild.2015.08.013>.
 - [18] C. Cornaro, V.A. Puggioni, R.M. Strollo, Dynamic simulation and on-site measurements for energy retrofit of complex historic buildings: Villa Mondragone case study, *J. Build. Eng.* 6 (2016) 17–28. <https://doi.org/10.1016/j.jobbe.2016.02.001>.
 - [19] T. Cardinale, G. Rospi, N. Cardinale, The influence of indoor microclimate on thermal comfort and conservation of artworks: The case study of the Cathedral of Matera (South Italy), in: *Energy Procedia*, Elsevier Ltd, 2014: pp. 425–432. <https://doi.org/10.1016/j.egypro.2014.10.398>.
 - [20] A. Revi, D. Satterthwaite, F. Aragon-Durand, J. Corfee-Morlot, R. R. Kiunsi, M. Pelling, D. Roberts, W. Solecki, S.P. Gajjar, A. Sverdlik, Towards transformative adaptation in cities: the IPCC's Fifth Assessment, *Environ. Urban.* 26 (2014) 11–28. <https://doi.org/10.1177/0956247814523539>.
 - [21] A.J. Prieto, K. Verichev, A. Silva, J. de Brito, On the impacts of climate change on the functional deterioration of heritage buildings in South Chile, *Build. Environ.* 183 (2020) 107138. <https://doi.org/10.1016/j.buildenv.2020.107138>.
 - [22] V. Rajčić, A. Skender, D. Damjanović, An innovative methodology of assessing the

climate change impact on cultural heritage, *Int. J. Archit. Herit.* 12 (2018) 21–35. <https://doi.org/10.1080/15583058.2017.1354094>.

- 1
2
3 [23] A. Haugen, C. Bertolin, G. Leijonhufvud, T. Olstad, T. Broström, A methodology for
4 long-term monitoring of climate change impacts on historic buildings, *Geosci.* 8 (2018).
5 <https://doi.org/10.3390/geosciences8100370>.
- 6
7 [24] S. Ramírez, M. Zarzo, A. Perles, F.J. García-Diego, A methodology for discriminant time
8 series analysis applied to microclimate monitoring of fresco paintings, *Sensors*
9 (Switzerland). 21 (2021) 1–29. <https://doi.org/10.3390/s21020436>.
- 10
11 [25] M. Gómez Heras, *La Temperatura en los Materiales del Patrimonio*, (2012) 87–95.
12 <http://digital.csic.es/handle/10261/46794>.
- 13
14 [26] Z. Pavlík, J. Fořt, R. Černý, An in situ monitoring system for the study of environmental
15 influences on durability and the destructive process of building materials and structures,
16 *WIT Trans. Modelling Simul.* 55 (2013) 287–296. <https://doi.org/10.2495/CMEM130231>.
- 17
18 [27] S. Michalski, *Temperatura Incorrecta*, Can. Conserv. Institute. ICCROM. (2009).
- 19
20 [28] S. Michalski, *Humedad relativa Incorrecta*, Can. Conserv. Institute. ICCROM. (2009).
- 21
22 [29] L. Villanueva Domínguez, A. García Santos, *Manual del yeso*, CIE Inversiones Editoriales,
23 2001.
- 24
25 [30] D. Freyer, W. Voigt, Crystallization and Phase Stability of CaSO₄ and CaSO₄ - Based
26 Salts, *Monatshefte Fur Chemie.* 134 (2003) 693–719. [https://doi.org/10.1007/s00706-](https://doi.org/10.1007/s00706-003-0590-3)
27 [003-0590-3](https://doi.org/10.1007/s00706-003-0590-3).
- 28
29 [31] E.M. Winkler, E.J. Wilhelm, Salt burst by hydration pressures in architectural stone in
30 urban atmosphere, *Geol. Soc. Am. Bull.* 81 (1970) 567–572.
31 [https://doi.org/https://doi.org/10.1130/0016-7606\(1970\)81\[567:SBHPI\]2.o.CO;2](https://doi.org/https://doi.org/10.1130/0016-7606(1970)81[567:SBHPI]2.o.CO;2).
- 32
33 [32] L. Ritterbach, P. Becker, Temperature and humidity dependent formation of
34 CaSO₄·xH₂O (x = 0...2) phases, *Glob. Planet. Change.* 187 (2020).
35 <https://doi.org/10.1016/j.gloplacha.2020.103132>.
- 36
37 [33] E. Goossens, *Moisture transfer properties of coated gypsum*, Technische Universiteit
38 Eindhoven, Faculteit Bouwkunde, 2003. <https://doi.org/10.6100/IR571306>.
- 39
40 [34] C.A.C. Mesquita, *Revestimientos Continuos Interiores de Varias Capas con*
41 *Características de Barrera de Vapor e Higroscopicidad*, Doctoral dissertation,
42 Polytechnic University of Madrid, 2012.
- 43
44 [35] R. Rubio Domene, *Yaserías de la Alhambra. Historia, técnica y conservación*, Patronato
45 de la Alhambra y Generalife. University of Granada, Granada, 2010.
- 46
47 [36] M. Torres-González, F.J. Alejandre, V. Flores-alés, A.I. Calero-castillo, F.J. Blasco-lópez,
48 Analysis of the state of conservation of historical plasterwork through visual inspection
49 and non-destructive tests . The case of the upper frieze of the Toledanos Room (The
50 Royal Alcázar of Seville , Spain), *J. Build. Eng.* 40 (2021) 1–14.
51 <https://doi.org/https://doi.org/10.1016/j.jobbe.2021.102314>.
- 52
53 [37] R. Campos de Alvear, The maintenance and the preventive preservation measures of the
54 cultural goods in the Royal Alcázar of Seville, *Apunt. Del Alcázar Sevilla.* 18 (2018) 71–
55 87.
- 56
57 [38] E. Correa Gómez, R. Rubio Domene, *El yeso. Las decoraciones de yeso en época nazarí*,
58 in: P. de la A. y Generalife (Ed.), *Man. Buenas Prácticas. Restauración Madera, Yeso y*
59
60
61
62
63
64
65

Cerámica, Patronato, Consejería de Educación, Cultura y Deporte de la Junta de Andalucía, Granada, 2014: pp. 43–52.

- [39] J.M. Cabrera Garrido, La influencia de los contaminantes en el Patrimonio artístico Nacional, *Econ. Ind.* 107 (1972) 51–60.
- [40] H. Viitanen, T. Ojanen, Improved Model to Predict Mold Growth in Building Materials, in: *Therm. Perform. Exter. Envel. Whole Build. X–Proceedings CD*, 2007: pp. 2–7.
- [41] G.A. Tsongas, F. Rioroan, Minimum conditions for visible mold growth, *ASHRAE J.* 58 (2016) 32–43.
- [42] D. Sanz Arauz, Análisis del yeso empleado en revestimientos exteriores mediante técnicas geológicas, *Doctoral dissertation*, Universidad Politécnica de Madrid, 2009. http://oa.upm.es/17111/1/DAVID_SANZ_ARAUZ.pdf.
- [43] A.I. Calero Castillo, A. García Bueno, O. López Cruz, V.J. Medina Flórez, La policromía original de las yeserías del Patio de las Doncellas del Real Alcázar de Sevilla. *Materiales constitutivos y técnicas de ejecución*, *Arqueol. y Territ. Mediev.* 24 (2017) 255–290. <https://doi.org/10.17561/aytm.v24i0.9>.
- [44] C. Sabbioni, P. Brimblecombe, M. Cassar, *The Atlas of Climate Change Impact on European Cultural Heritage: Scientific Analysis and Management Strategies*, Anthem Press, London, UK, 2010.
- [45] A. Almagro Gorbea, El Alcázar de Sevilla Un palacio musulmán para un rey cristiano, in: *Cris. y Musulmanes En La Península Ibérica La Guerr. La Front. y La Convivencia. XI Congr. Estud. Mediev.*, 2007: pp. 331–365.
- [46] F.J. Blasco López, Yeserías medievales de tradición islámica del Real Alcázar de Sevilla: Revisión Historiográfica, Metodología para la caracterización, evaluación de su durabilidad y elaboración de un inventario, *Doctoral dissertation*, University of Seville, 2011.
- [47] A.I. Calero Castillo, *Materiales, técnicas y procedimientos en la decoración arquitectónica. Aplicaciones a la conservación y restauración de las yeserías del Patio de las Doncellas. Real Alcázar de Sevilla.*, *Doctoral dissertation*, Universidad de Granada, 2016. <http://hdl.handle.net/10481/43864>.
- [48] A. Pleguezuelo, Tile-work in the mudéjar palace in the Royal Alcázar of Seville. *A Preliminary Visual Analysis.*, *Apunt. Del Alcázar Sevilla.* 16 (2015) 219–230.
- [49] C. Enríquez Díaz, J.R. Baeza Álvarez, A project for the restoration of the tilings of the ground floor of the mudéjar palace, *Apunt. Del Alcázar Sevilla.* 19 (2019) 65–77.
- [50] C. Cañas Palop, Las armaduras de cubiertas mudéjares del palacio de Pedro I, del Alcázar de Sevilla: análisis integral y propuestas para la restauración, *Doctoral dissertation*, University of Seville, 2006. <https://dialnet.unirioja.es/servlet/tesis?codigo=23333>.
- [51] S. Fernández Aguilera, Portaventaneros mudéjares en el Real Alcázar de Sevilla, *Archivo Hi*, Diputación Provincial de Sevilla, Sevilla, 2012.
- [52] F.M. Tubino, *Estudios sobre el arte en España. La arquitectura hispano-visigoda y árabe española. El Alcázar de Sevilla. Una iglesia mozárabe*, 1886.
- [53] The Government of Spain, *Royal Decree 314/2006. Approving the Spanish Technical Building Code*, Madrid, Spain, 2013.
- [54] M. Kottek, J. Grieser, C. Beck, B. Rudolf, F. Rubel, *World map of the Köppen-Geiger*

- 1
2
3
4 climate classification updated, *Meteorol. Zeitschrift.* 15 (2006) 259–263.
5 <https://doi.org/10.1127/0941-2948/2006/0130>.
- 6
7 [55] L. Webster, J. Bradford, *Measurement and Verification for Federal Energy (M&V*
8 *Guidelines)*, 2008.
- 9
10 [56] ANSI/ASHRAE, *ASHRAE Guideline 14-2002 Measurement of Energy and Demand*
11 *Savings*, Ashrae. 8400 (2002) 170.
- 12
13 [57] G.R. Ruiz, C.F. Bandera, *Validation of calibrated energy models: Common errors,*
14 *Energies.* 10 (2017). <https://doi.org/10.3390/en10101587>.
- 15
16 [58] Efficiency Valuation Organization, *International Performance Measurement &*
17 *Verification Protocol*, *Handb. Financ. Energy Proj. I* (2016) 122.
- 18
19 [59] M.F. Jentsch, A.S. Bahaj, P.A.B. James, *CCWorldWeatherGen, Climate change world*
20 *weather file generator, Version 1.8*, *Sustain. Energy Res. Gr.* (2013).
- 21
22 [60] I.P. on C. Change, *Summary for Policymakers*, in: *Intergovernmental Panel on Climate*
23 *Change (Ed.), Clim. Chang. 2013 - Phys. Sci. Basis*, Cambridge University Press,
24 Cambridge, 2014: pp. 1–30. <https://doi.org/10.1017/CBO9781107415324.004>.
- 25
26 [61] J.R. Quinlan, others, *Learning with continuous classes*, in: *5th Aust. Jt. Conf. Artif. Intell.,*
27 *1992*: pp. 343–348.
- 28
29 [62] Y. Wang, I.H. Witten, *Induction of model trees for predicting continuous classes*, in: *Eur.*
30 *Conf. Mach. Learn., Prague: University of Economics, Faculty of Informatics and*
31 *Statistics*, 1997.
- 32
33 [63] A. Behnood, V. Behnood, M. Modiri Gharehveran, K.E. Alyamac, *Prediction of the*
34 *compressive strength of normal and high-performance concretes using M5P model tree*
35 *algorithm*, *Constr. Build. Mater.* 142 (2017) 199–207.
36 <https://doi.org/10.1016/j.conbuildmat.2017.03.061>.
- 37
38 [64] L. Lin, Q. Wang, A.W. Sadek, *A combined M5P tree and hazard-based duration model*
39 *for predicting urban freeway traffic accident durations*, *Accid. Anal. Prev.* 91 (2016) 114–
40 126. <https://doi.org/10.1016/j.aap.2016.03.001>.
- 41
42 [65] F. Afsarian, A. Saber, A. Pourzangbar, A.G. Olabi, M.A. Khanmohammadi, *Analysis of*
43 *recycled aggregates effect on energy conservation using M5" model tree algorithm*,
44 *Energy.* 156 (2018) 264–277. <https://doi.org/10.1016/j.energy.2018.05.099>.
- 45
46 [66] C.F. Jeffrey Kuo, C.H. Lin, M.H. Lee, *Analyze the energy consumption characteristics*
47 *and affecting factors of Taiwan's convenience stores-using the big data mining*
48 *approach*, *Energy Build.* 168 (2018) 120–136.
49 <https://doi.org/10.1016/j.enbuild.2018.03.021>.
- 50
51
52
53
54
55
56
57
58
59
60
61
62
63
64
65

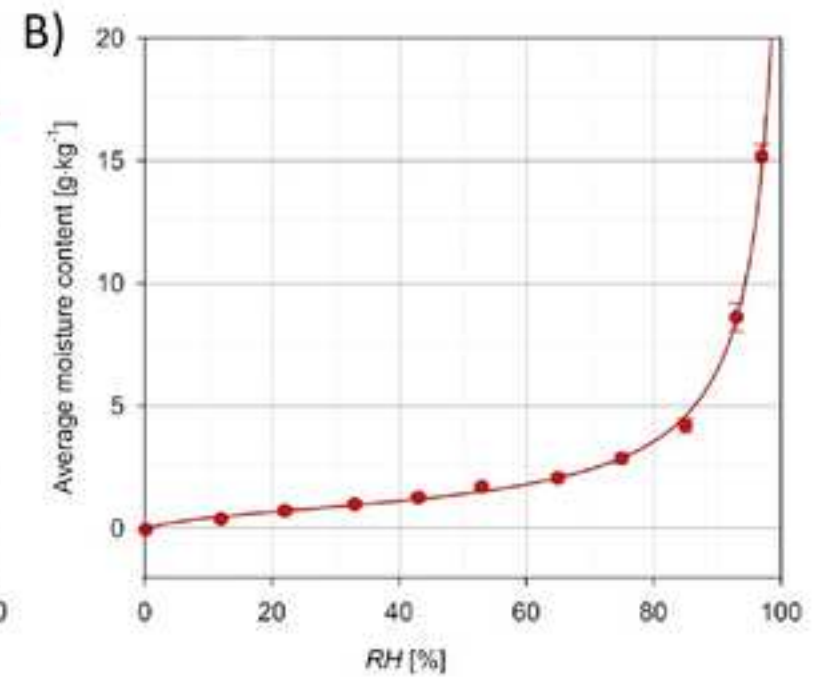
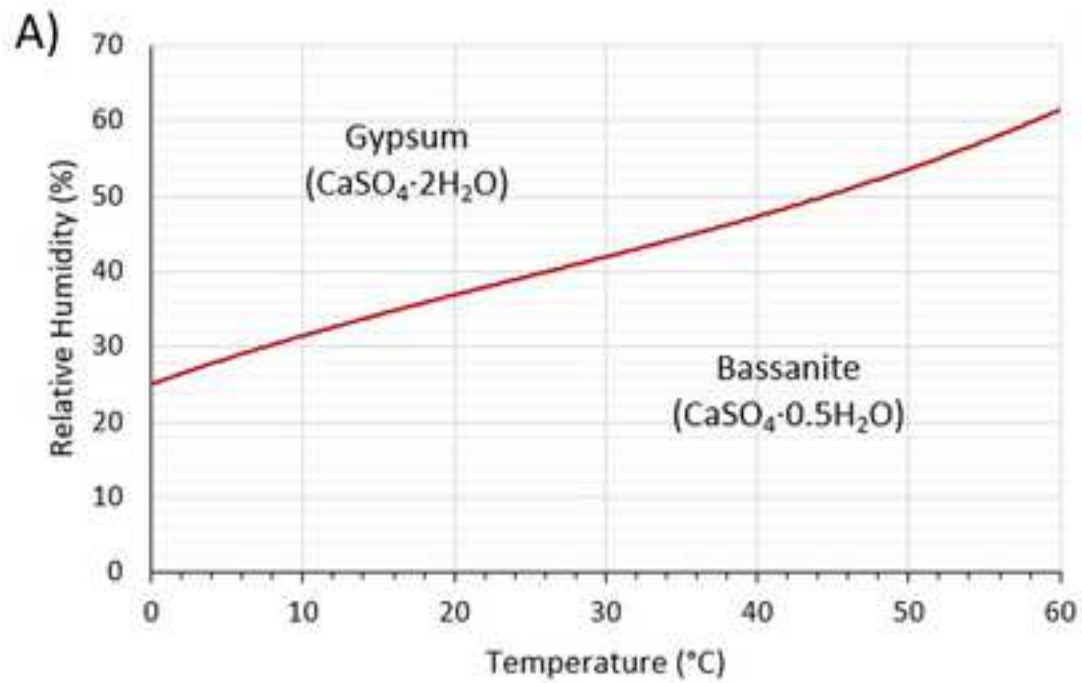

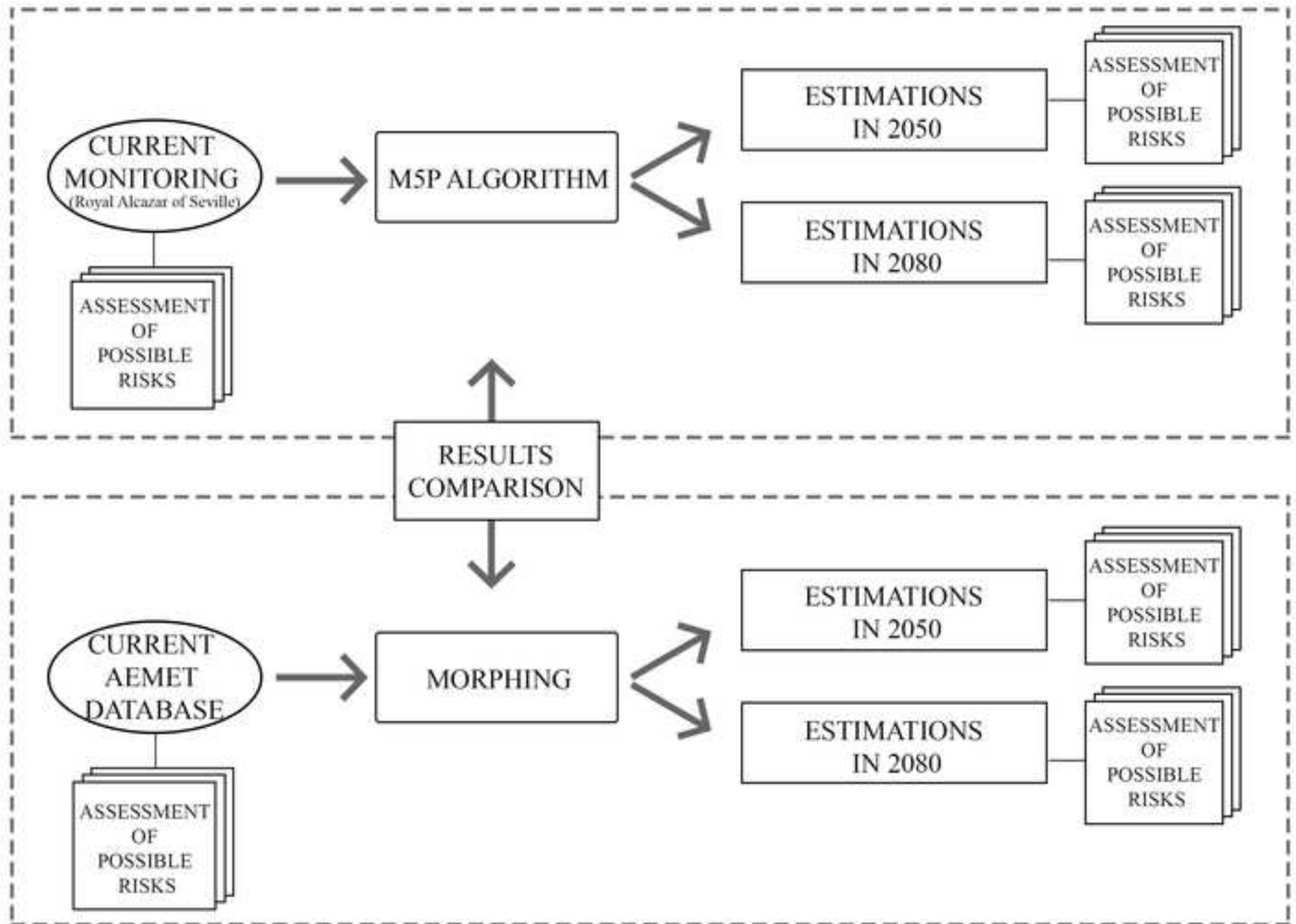
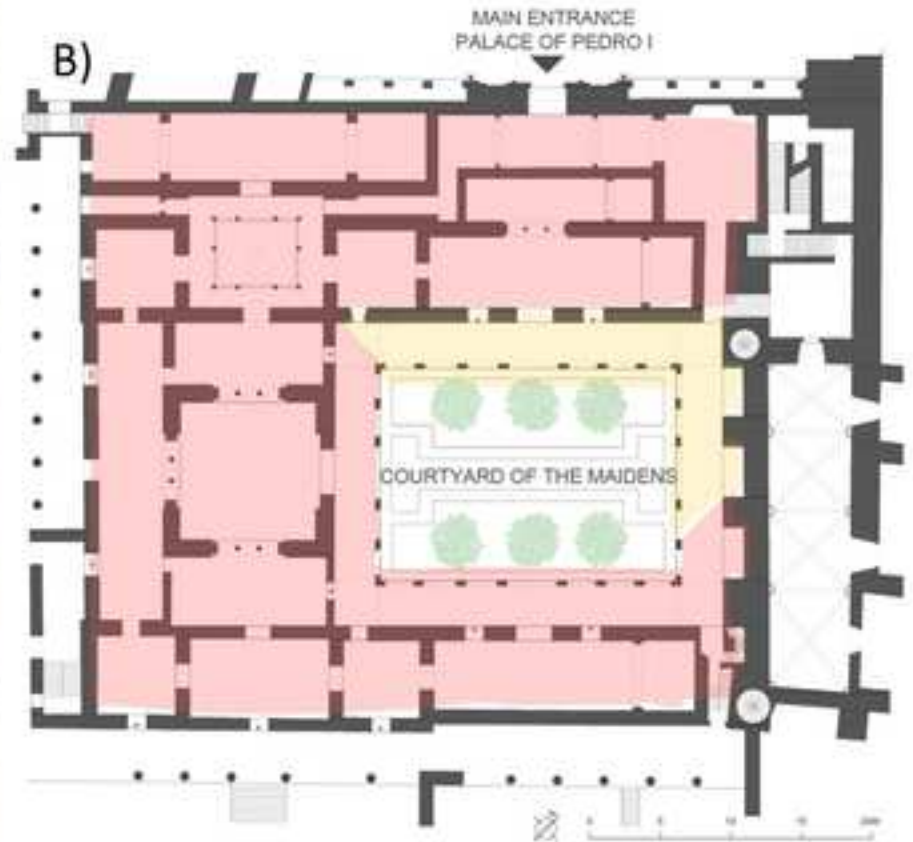
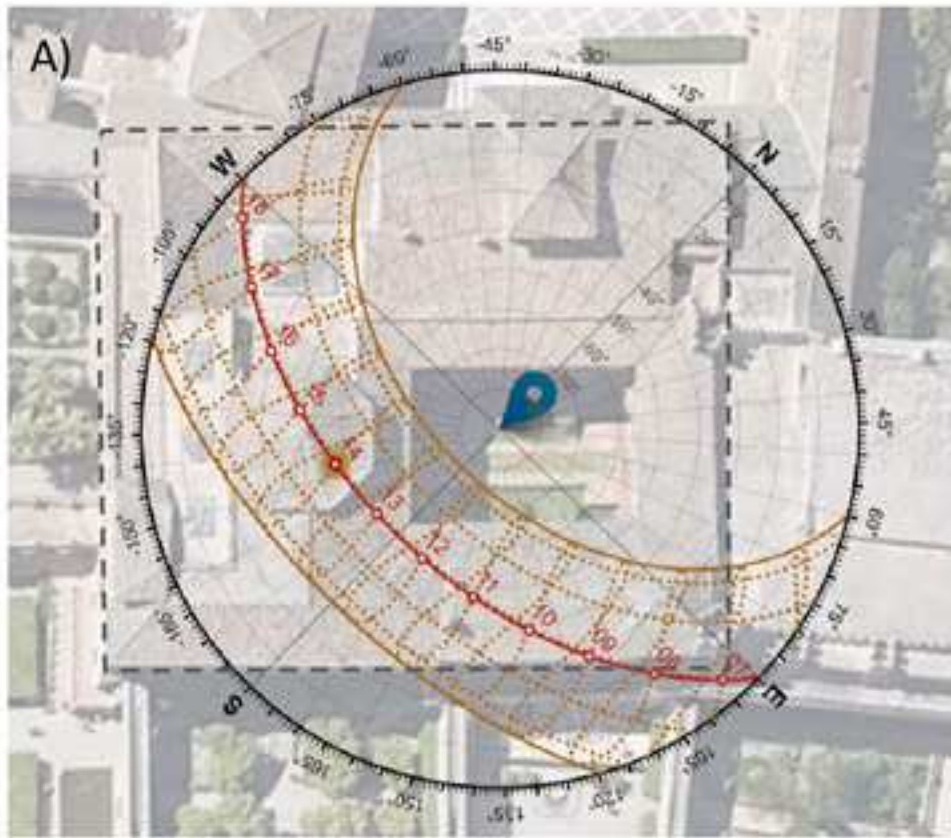

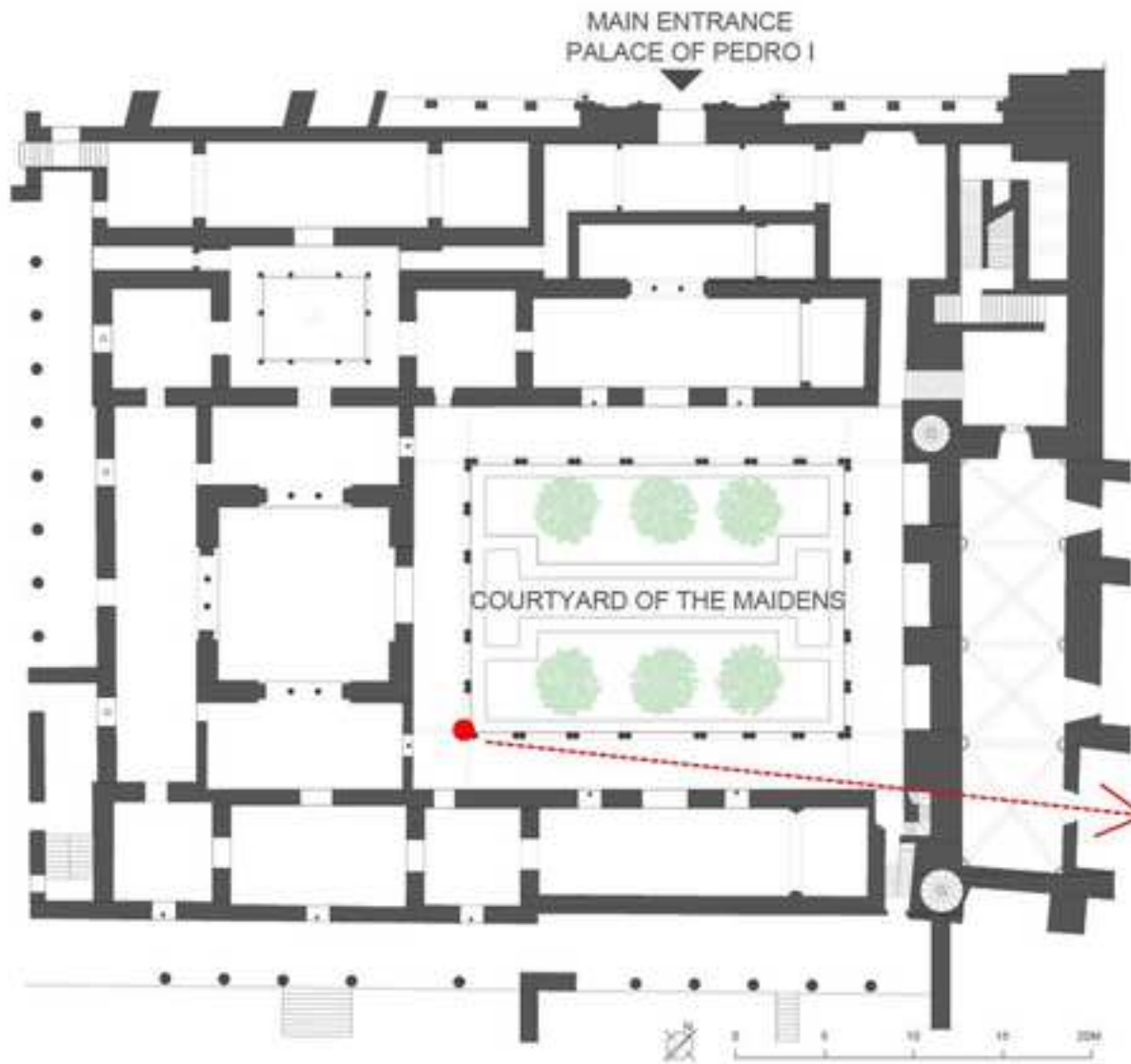

Figure 4

[Click here to access/download;Figure \(Do not upload picture, .svg format. Upload only PDF, eps or tiff format\);Figure 04.jpg](#)







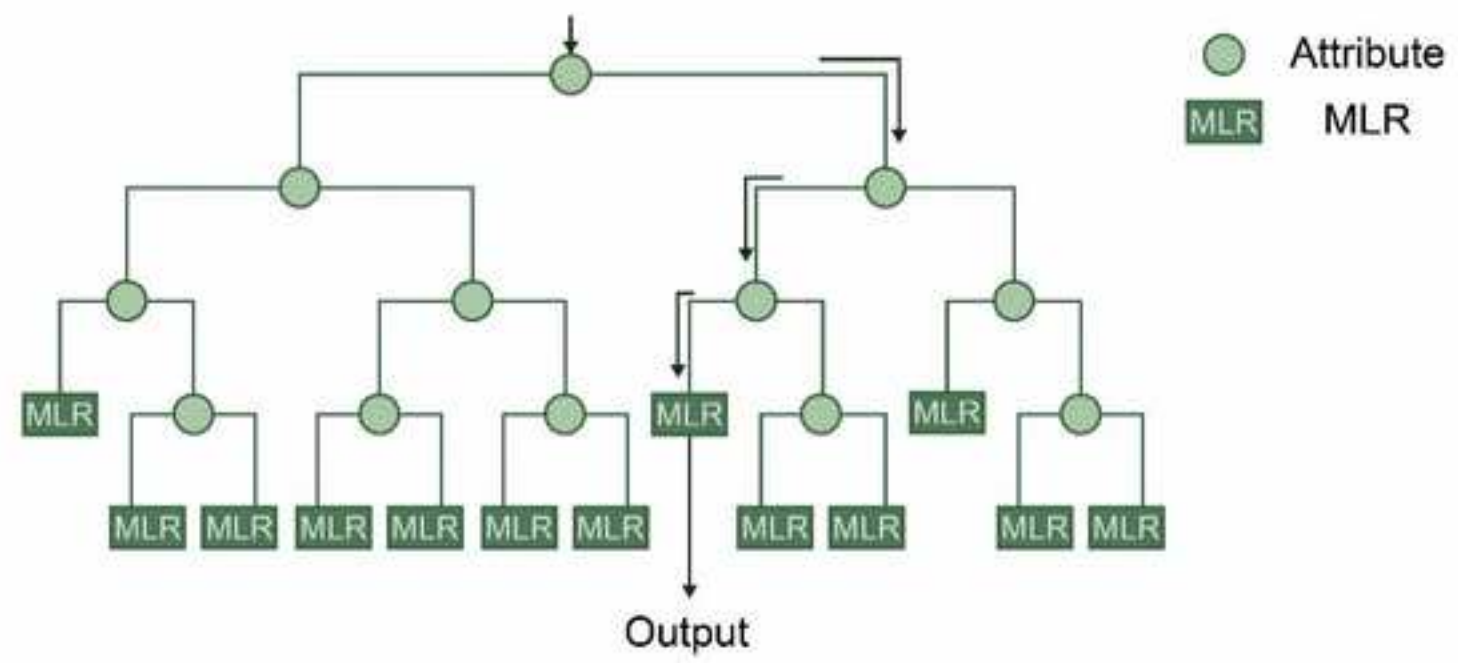

Figure 8

Click here to access/download;Figure (Do not upload picture, .svg format. Upload only PDF, eps or tiff format);Figure 08.jpg

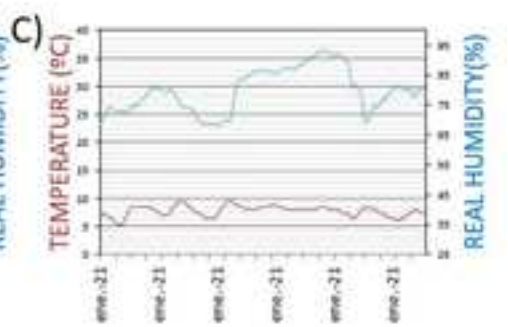
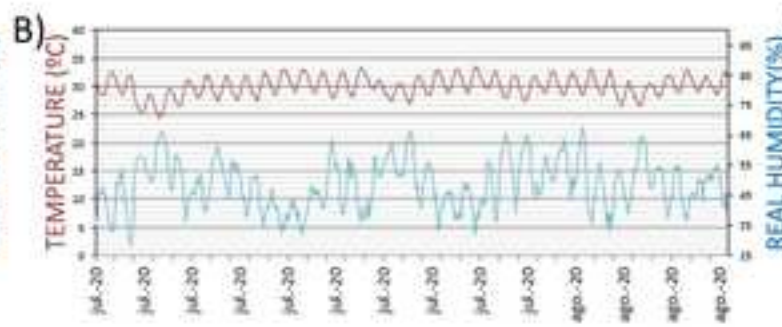
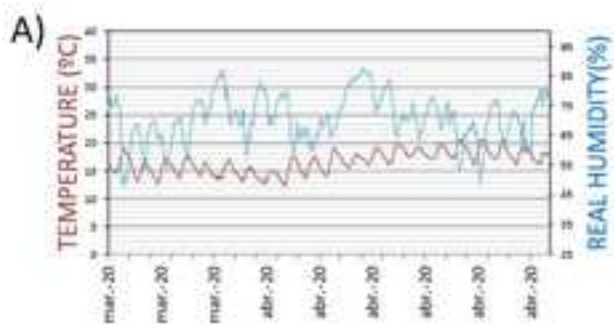
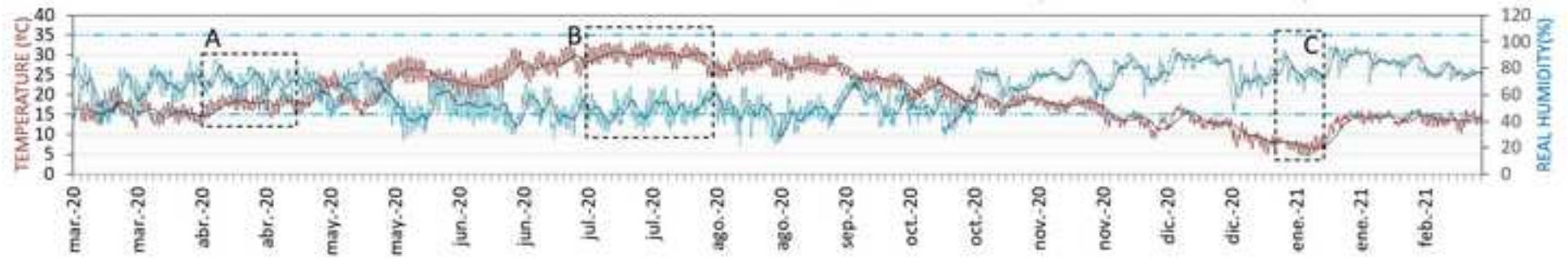
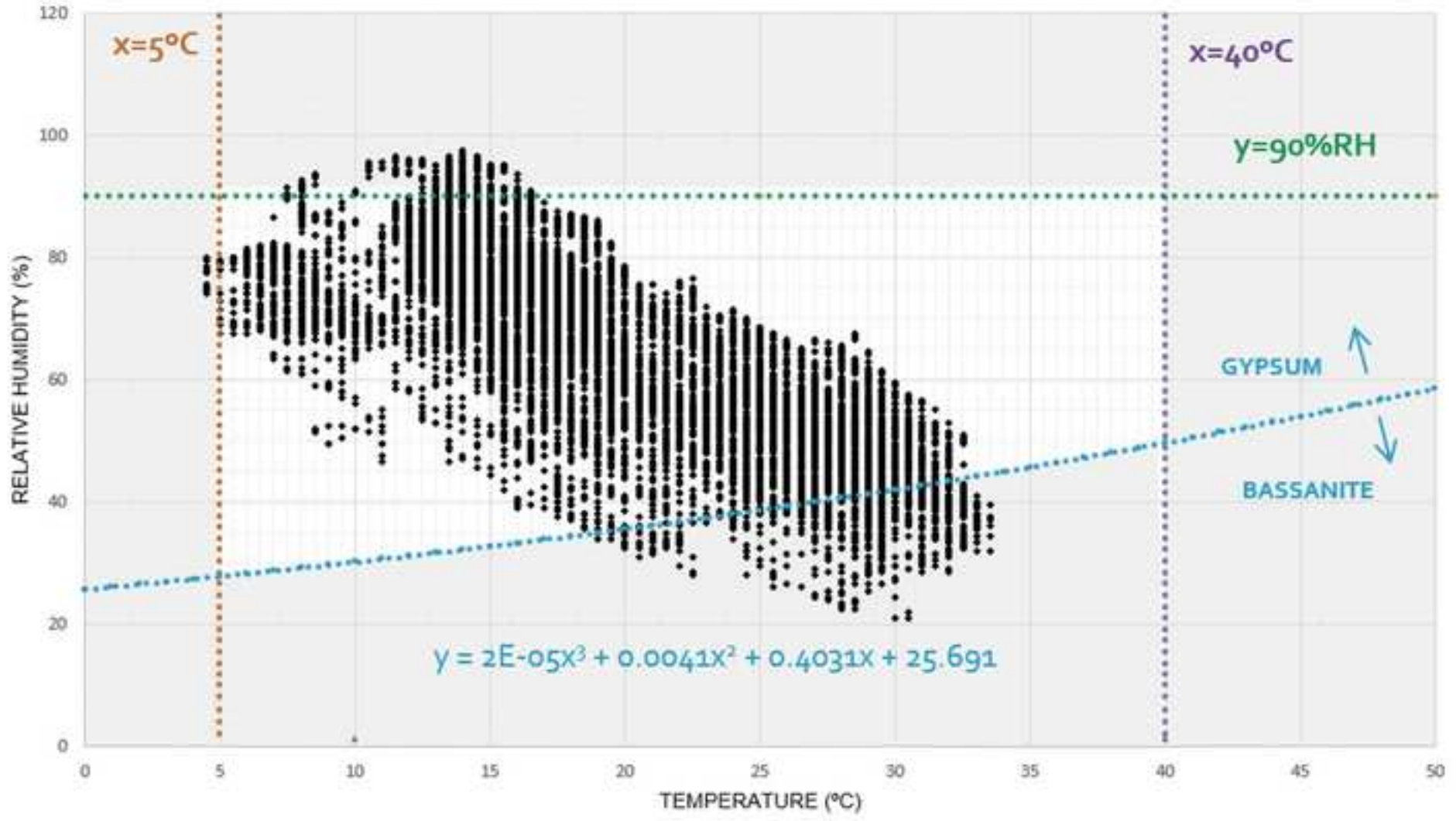

Figure 9



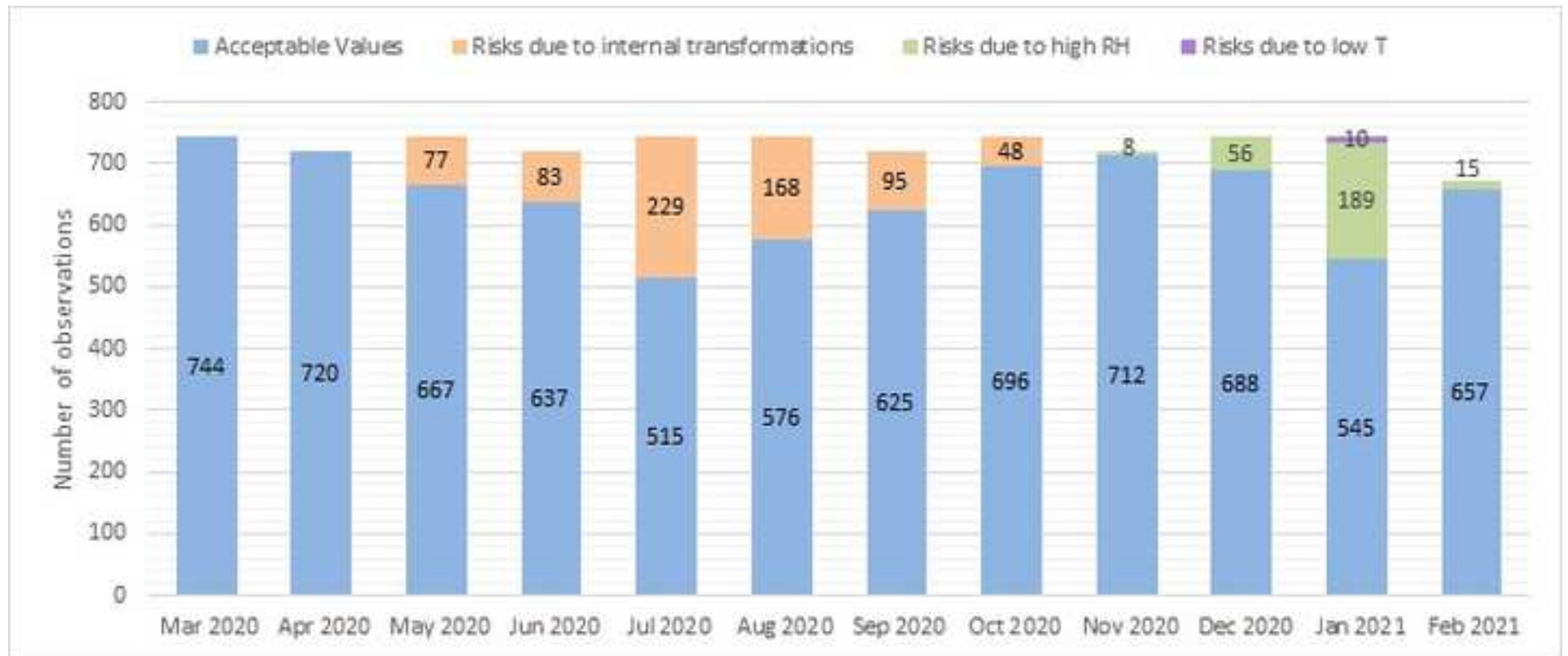
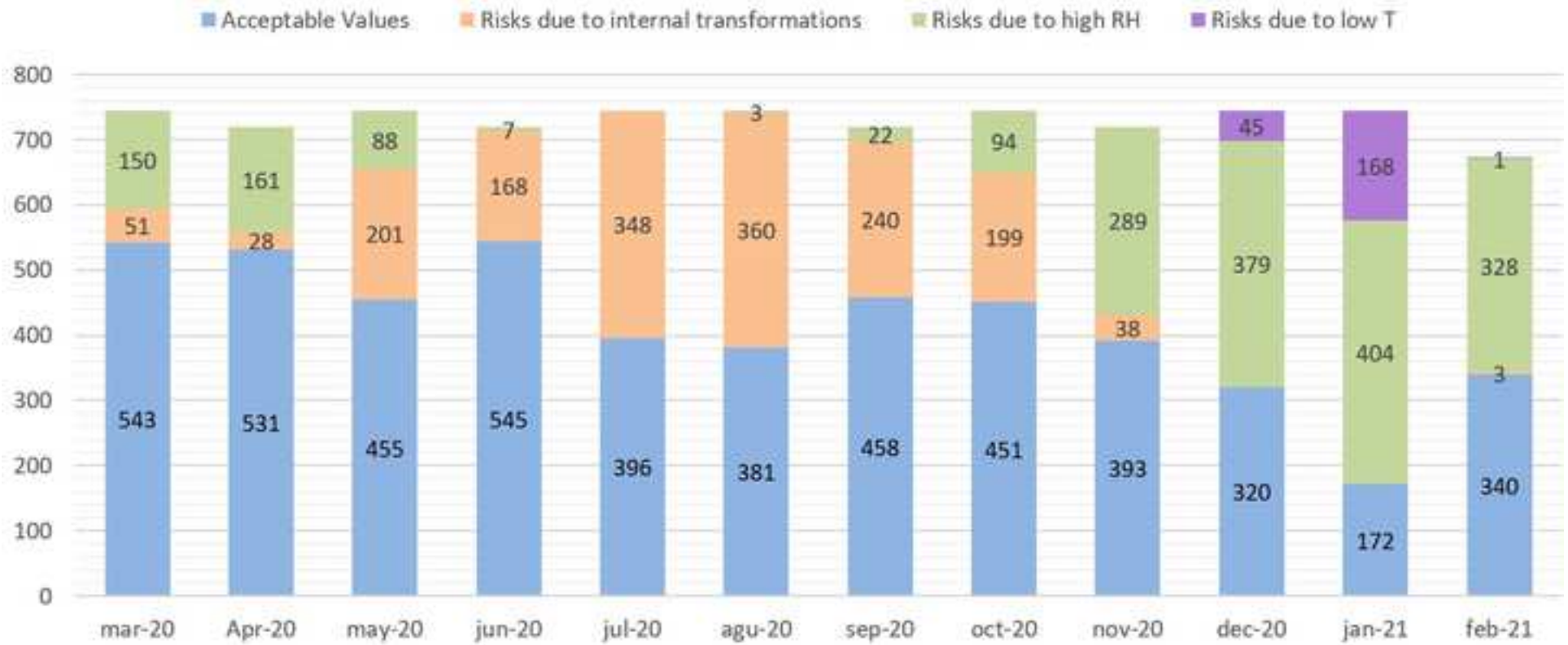
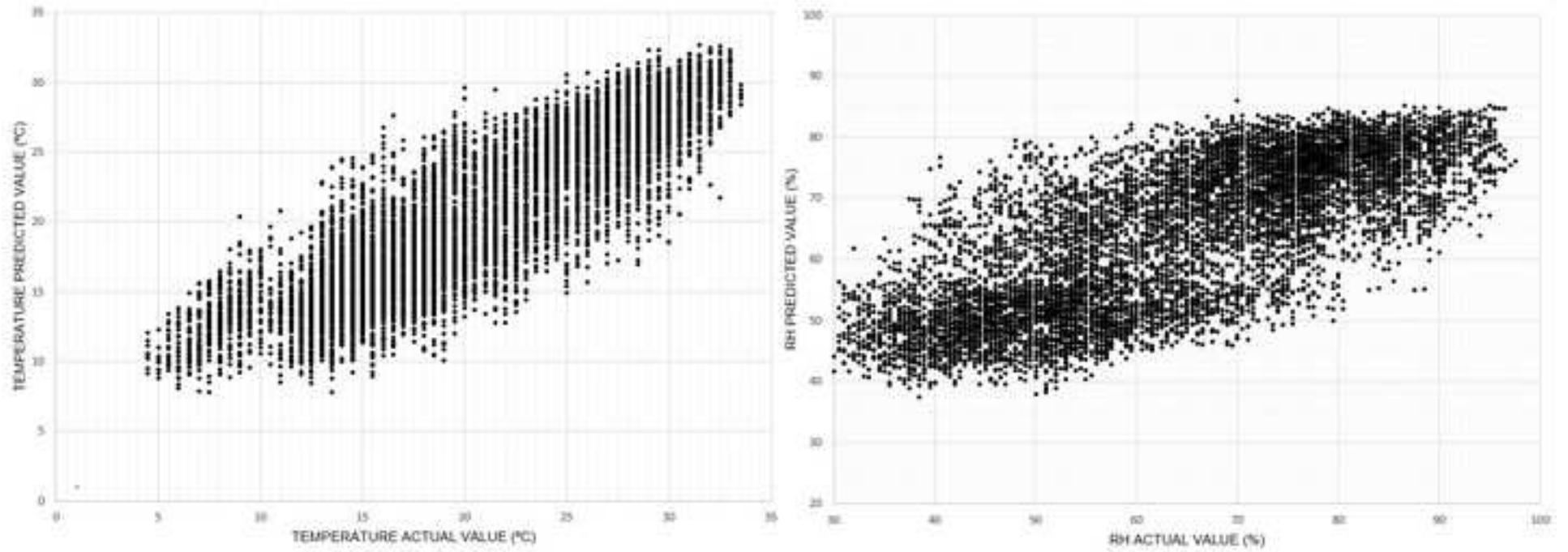
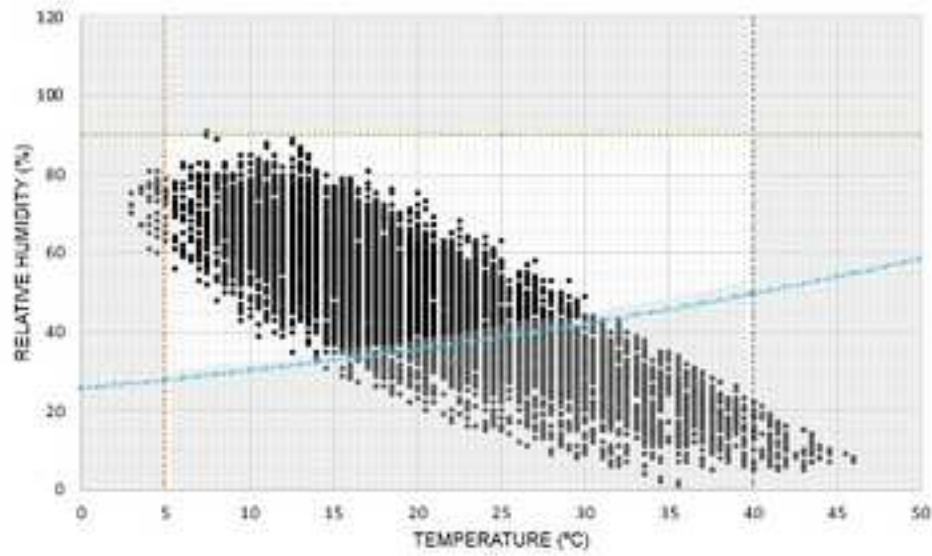

Figure 11







2050 - CTE

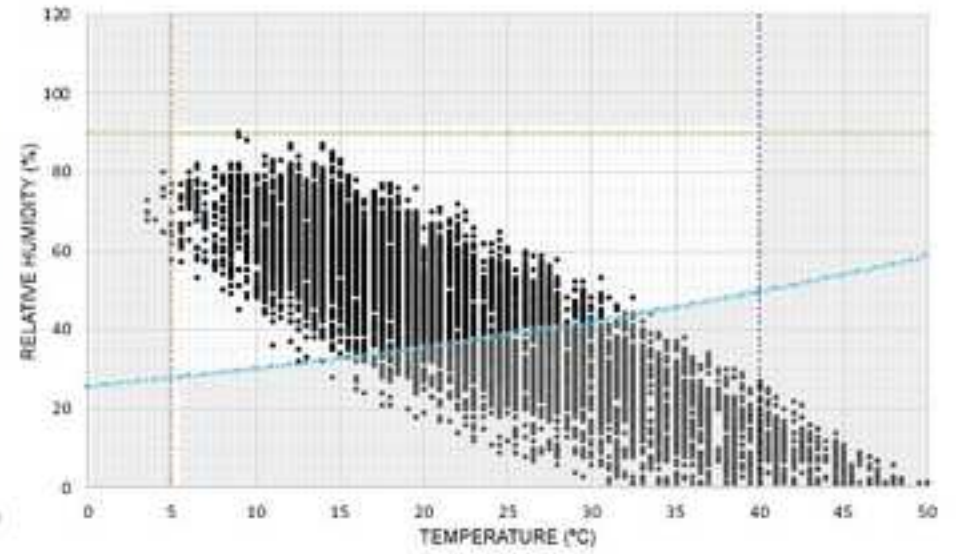

2080 - CTE

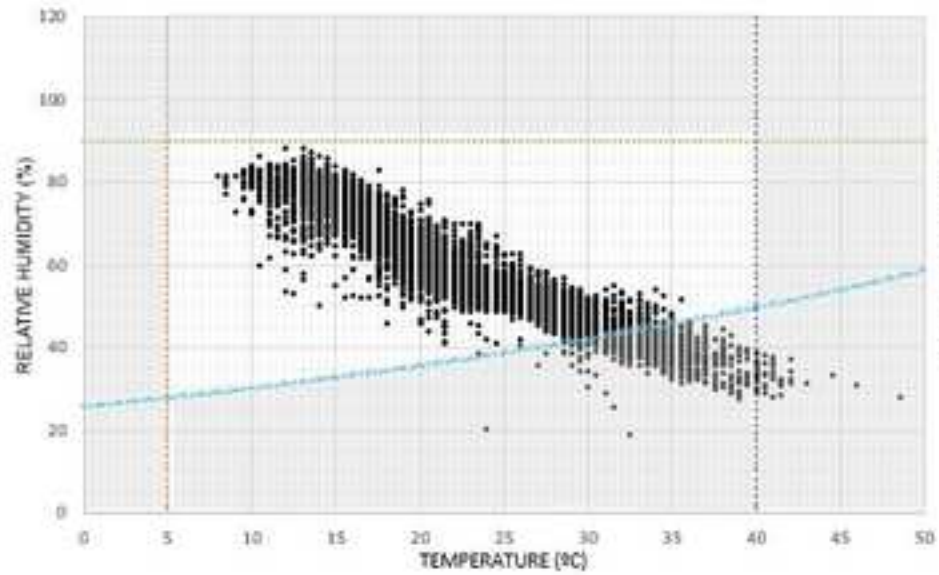

2050 - RAS

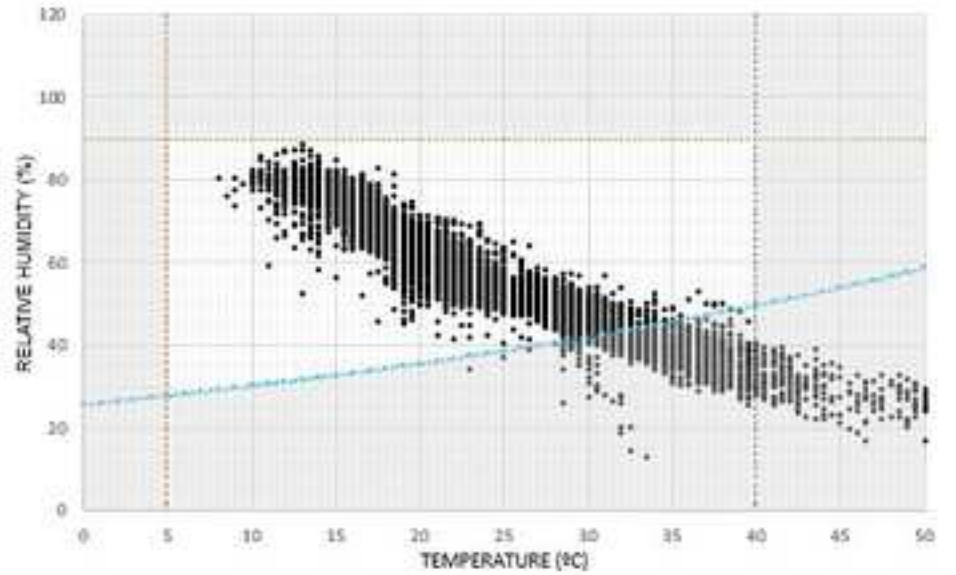

2080 - RAS

ASSESSMENT OF AMBIENT CONDITIONS IN THE CLIMATE ZONE ESTIMATED BY EPW

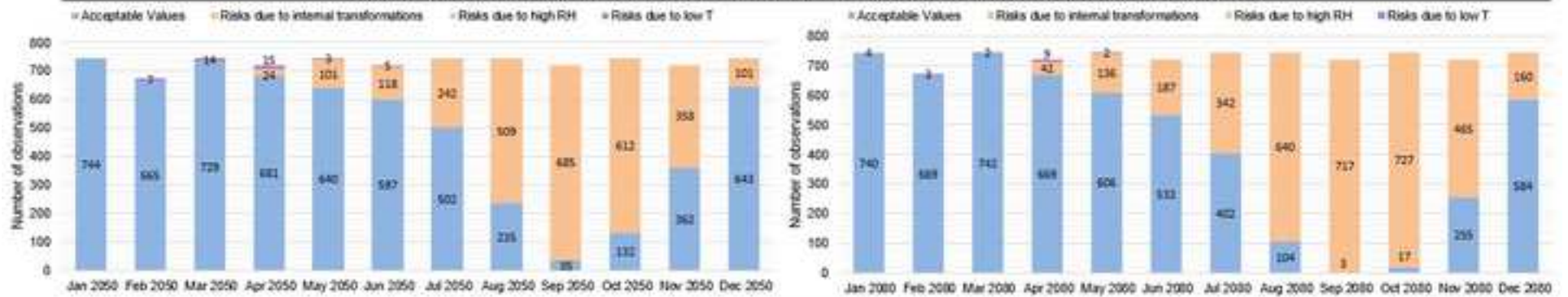

ASSESSMENT OF AMBIENT CONDITIONS IN THE ROYAL ALCAZAR OF SEVILLE ESTIMATED BY M5P

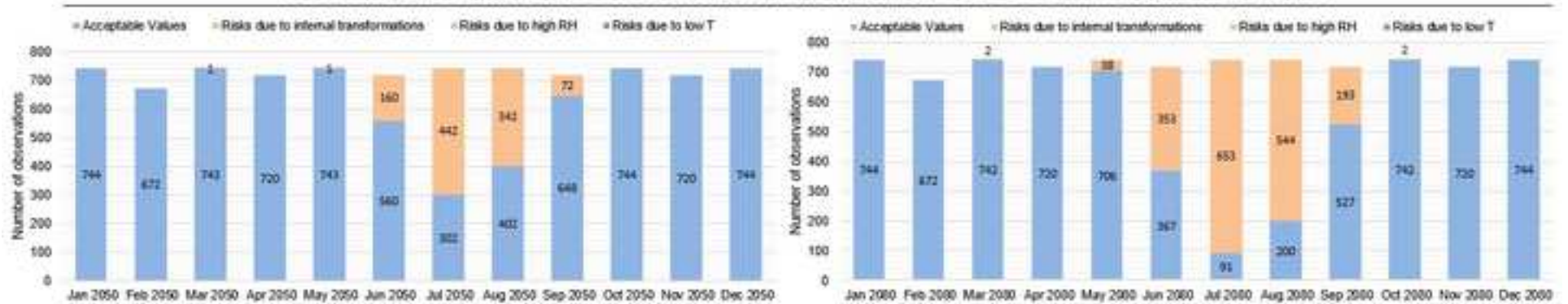

Table 1. Summary of environmental parameters from 01/03 /2020 to 28 / 02/2021.

Months	RELATIVE HUMIDITY (%)					TEMPERATURE (° C)				
	Min. Values registered		Max. values registered		Δ (max-min)	Min. Values registered		Max. values registered		Δ (max-min)
	Average	SD	Average	SD		Average	SD	Average	SD	
Feb 20	55.3	11,001	73.8	9,454	18.5	14	1,319	18.1	1,577	4.1
Ap. 20	60.6	6,672	77.7	4,79	17.1	15.7	1,534	19.2	1,558	3.5
May 20	43.3	10,818	64.1	9,947	20.8	21.3	2,337	26.1	2,832	4.8
Jun 20	41.4	5,608	62	7,87	20.6	22.3	2,434	27.3	2,314	5
Jul. 20	38	5,877	56	7,43	18	27.6	1,448	31.8	1,328	4.2
Aug. 20	38	8,637	56.5	7,966	18.5	26.3	1,675	30.5	1,581	4.2
Sept. 20	44.1	9,493	58.3	8,287	14.2	24	1.9	27.4	2,105	3.4
Oct. 20	49.3	12,985	63.1	11,674	13.8	18.1	1,996	21.3	2,136	3.2
Nov. 20	70	8,459	78.6	7,134	8.6	15.6	1,964	17.9	1,965	2.3
Dec. 20	74.2	10,822	84.4	8,133	10.2	11.4	2,366	13.7	1,935	2.3
Jan. 21	75.2	9,545	86.1	8,141	10.9	8.6	3,493	11.2	3,093	2.6
Feb. 21	77.4	5,562	83.1	5,129	5.7	12.9	1,127	15.1	0.854	2.2

Table 2. Calibration of measured data in RAS compared to CTE. Limit values according to ASHRAE Guideline14.

Variable	NMBE [%]		CV (RMSE) [%]	
	Obtained values	Limit values	Obtained values	Limit values
Temperature (T)	11.03	± 10	25.34	30
Relative humidity (RH)	15.52	± 10	27.08	30

Table 3. Performance obtained by the M5P models in the training and validation phase.

Approach	Output variable	Determination coefficient (R2)	MBE
M5P 1	Temperature (T)	86.53%	2.6
M5P 2	Relative Humidity (RH)	74.93%	8.0

Declaration of interests

The authors declare that they have no known competing financial interests or personal relationships that could have appeared to influence the work reported in this paper.

The authors declare the following financial interests/personal relationships which may be considered as potential competing interests:

Journal of Building Engineering

Dear Editor:

Manuscript title: "LONG-TERM MONITORING FOR PREVENTIVE CONSERVATION OF HISTORICAL PLASTERWORKS"

As corresponding author, I certify that the co-authors of this manuscript have NO affiliations with or involvement in any organization or entity with any financial interest (such as honoraria; educational grants; participation in speakers' bureaus; membership, employment, consultancies, stock ownership, or other equity interest; and expert testimony or patent-licensing arrangements), or non-financial interest (such as personal or professional relationships, affiliations, knowledge or beliefs) in the subject matter or materials discussed in this manuscript.



Vicente Flores-Alés
Universidad de Sevilla

AUTHOR STATEMENT

M. Torres-González: Investigation, data discussion, Writing, Review & Editing

C.Rubio-Bellido: Conceptualization, Investigation, data discussion, Validation

D. Bienvenido-Huertas: Conceptualization, Investigation, Software, data discussion

J.M. Alducin-Ochoa:, Investigation, Statistical analysis, Formal analysis

V. Flores-Alés: Conceptualization, Methodology, Investigation, Validation

LONG-TERM ENVIRONMENTAL MONITORING FOR PREVENTIVE CONSERVATION OF EXTERNAL HISTORICAL PLASTERWORKS

Marta Torres-González ^{a,b} *, Carlos Rubio-Bellido ^a, David Bienvenido-Huertas ^a, JM Alducin-Ochoa ^a, V. Flores-Alés ^a,

^aDepartment of Architectural Construction II, University of Seville

^bDepartment of Civil Engineering, Architecture and Georesources, University of Lisbon

* Corresponding author: mtorres18@us.es , Av Reina Mercedes 4, Seville, 41012

KEYWORDS: plasterwork; temperature; relative humidity; architectural heritage; preservation;

ABSTRACT:

In this study, an analysis of the environmental conditions in a Csa climatic zone for the conservation of plasterwork of the Real Alcázar of Seville is carried out. The measurements obtained from in-situ monitoring are compared with the measurements provided by AEMET (State Meteorological Agency in Spain) during the reference year and the study is completed by estimating future environmental conditions using two alternative approaches: a morphing process from the EPW of the climatic zone and the application of M5P data mining algorithms.

An optimal temperature range is established for the conservation of the plasterwork that prevents their dehydration or the freezing of water particles contained. The transformation of gypsum into bassanite, the risks associated with exposures to high relative humidity and the consequences of the slight hygroscopicity of the material and the environmental conditions that must be developed to favor the growth of mold on the surface or the cracking of polychromies that embellish these plaster decorations on numerous occasions are analyzed. The results obtained allow us to establish preventive conservation measures not only on the plasterwork but also on the Real Alcázar of Seville and that architectural heritage located in the subtropical dry-summer climate.

1. INTRODUCTION

1.1 Thermo-hygrometric conditions and the conservation of the architectural heritage.

The preventive conservation of heritage is crucial so that future generations can know the identity traits of their culture [1]. Therefore, the monitoring and analysis of specific environmental conditions [2] and their impact on **architectural heritage**, as well as future vulnerabilities due to global warming [3], are currently a challenge.

There are numerous studies that analyze both the impact of environmental conditions on architectural heritage [4,5] and the conditioning of interior spaces to favor the preservation of objects (e.g., objects that belong to exhibitions) [6,7]. In both cases, there are national and international guidelines and standards that establish the interior air conditioning conditions of these buildings for such purposes, such as UNI 10829 Standard [8], UNE EN 15757 [9], ASHRAE STANDARD 55-2020[10] or the British PAS 198 [11]. Likewise, EN 15759-1 [12] also considers the possibility of using heating systems **to achieve** thermal comfort and for the optimal conservation of heritage elements.

In addition to international standards, numerous studies have carried out thermo-hygrometric monitoring of architectural heritage in recent decades, resulting in a very useful tool to assess the state of conservation of the building and to know the causes of the degradation in order **to determine a** future restoration intervention or to establish preventive conservation criteria, ruling out the use of destructive techniques. Thus, long-term studies of up to 20 years duration [13,14] and studies in which monitoring is limited to one year [15] have been published. In this regard, it is common to evaluate at least annual monitoring periods that are **complemented by** thermal models on which different estimates of environmental conditions are established. **Environmental monitoring and simulation tools make it possible to establish estimates of different factors, such as the modification of operational patterns, thermal comfort [16-18], or**

energy conservation measures [19]. However, the impact of climate change, the basis of numerous investigations related to cities [20,21] has been sparsely discussed in reference to preventive conservation of heritage and long-term adverse aspects, which could become very significant [22,23].

1.2 Relative humidity and temperature influence in the preservation of historical plasterwork.

There are studies about how ambient conditions could affect constructive materials [24–28] but are insufficient with respect to gypsum or plasterwork. In this sense, it is worth highlighting the importance of follow-up campaigns to identify possible risks for the conservation of the plasterwork, prevent irreversible damage and advance conservation strategies. However, to account for all the possible damage mechanisms, a comprehensive methodology should be used to evaluate some risk indexes based on ambient temperature (T) and relative humidity (RH) measurements.

Gypsum, due to its porous microstructure formed by crystalline groups of hydrated calcium sulfate, can incorporate water molecules inside, in the form of water vapor or even in the form of liquid water, when environmental conditions favor capillary condensation. Furthermore, gypsum has the ability to eliminate this water when environmental conditions change, reducing the content of water vapor in contact with the material [29].

Variations in T and RH can induce phase transitions. In general, gypsum ($\text{CaSO}_4 \cdot 2\text{H}_2\text{O}$) dehydration occurs in dry environments [30], which is the reason why temperature below 40°C is desirable for the correct preservation of plasterwork. However, there may be situations of high temperatures combined with high relative humidity in which there are no alterations in the mineral phases of the gypsum [31]. In this regard, Winkler & Wilhelm (1970) indicated the relationship that must exist between ambient temperature and relative humidity to transform gypsum ($\text{CaSO}_4 \cdot 2\text{H}_2\text{O}$) into bassanite ($\text{CaSO}_4 \cdot 0.5\text{H}_2\text{O}$) [31], In this case, the material is likely to

lose stability if exposure to these unfavorable environmental conditions is prolonged over time [32] (Fig. 1-A, 1-B).

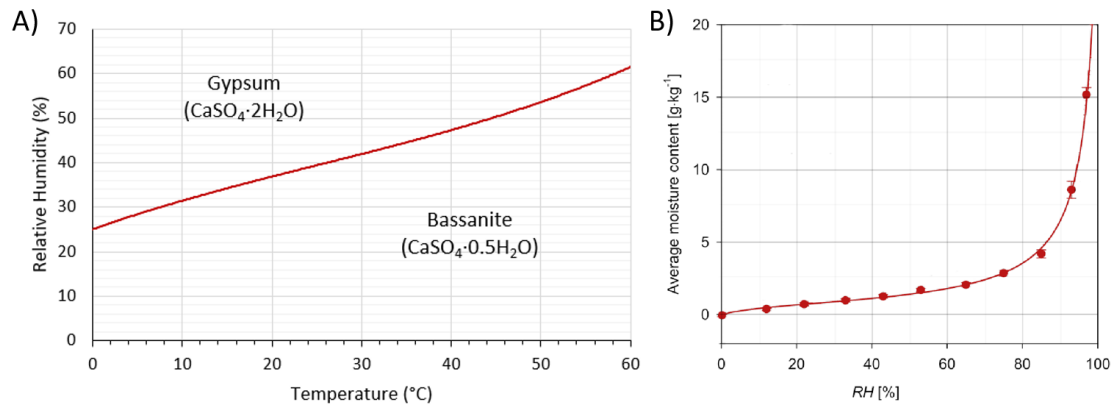

Fig. 1 (A) T-HR ratio for gypsum-bassanite transformation at 1 atmosphere pressure [31] and (B) Relationship between the relative humidity and the moisture content of the gypsum [33].

However, this transformation is part of a reversible process in plasterwork, which means that a rehydration would allow the recovery of the initial properties as long as the dehydration had not been prolonged in time until it remained constant, due to a change in climatic conditions, causing the mechanical weakening of the plasterwork [32].

Additionally, gypsum has low hygroscopicity [33,34] and medium-low solubility [35] that do not represent a direct risk in the preservation of plasterwork [36]. However, it is important to control the environmental conditions because the condensation of moisture on the surface of the plasters favors the alteration of the polychrome binders and their possible detachment [33].

The adsorption hygroscopicity of gypsum with 80% RH is only 4 g/kg (0.4%) [33], reaching a high adsorption hygroscopicity only by capillary saturation (99% RH) [34]. Likewise, humidity favors the nesting of biotic organisms and the alteration derived from their activity [33].

Therefore, an RH close to or greater than 90% weakens the structure of the plasterwork and favors the proliferation of microorganisms and biological agents, as well as the fixation of environmental pollutants.[37–39] (Fig. 01-B).

The concentration of water vapor inside rooms can produce condensation dampness in the sufficiently cold walls, which can generate the appearance of molds or small fungi in the plaster decorations in the absence of ventilation [29]. The appearance of mold or the growth of organisms would therefore be another factor that **accelerate** the degradation of plasterwork [40]. However, and taken into account that this fact depends on the type of support, the conditions of temperature and humidity, the ventilation and the type of microorganism in question, what has been stated by Tsongas&Rioroan (2016) [41] has been followed; they indicate that below a relative equilibrium humidity of 80% -85% the growth and proliferation of most fungi is hindered.

Temperatures below 0°C could imply the start of freezing and expansion processes of the water, swelling the material and causing irreversible damage to the plasterwork. In this regard, a saturation modulus of less than 75% indicates that the ratio of open pores to total pores is low enough so that the material does not have frost problems [42]. However, in the case study presented, this lower limit temperature does not pose any risk since it will hardly be reached at these latitudes.

The alterations suffered by the polychromies present on the plasterwork as a result of the loss of cohesion due to the humidity of the plaster could also be taken into consideration [43]. In the pictorial layers on plasterwork, generally made in tempera, the presence of humidity implies the alteration of the binders. On the other hand, in the cases in which re-polichromies with oils and waxes or gilded in later times are identified, the presence of humidity can prevent the perspiration of the layers and, therefore, accelerate the degradation processes.

The craquelure or stiffening of the pictorial layers that cover a large part of the plasterwork surface begins at low temperatures [27], favoring their partial detachments, being the range of recommended temperatures for the correct preservation of the polychromies 10-24°C [8].

1.3. Aim of this study

The influence of environmental conditions on the conservation of plasterwork plays a main role. Given this circumstance, the expected climate change in hot regions could lead to a variation in conservation conditions. In this sense, it should be noted that in the scientific literature there are few studies aimed at analyzing the impact of climate change on conservation risk, despite the fact that estimates show that the impact may be significant [22,44]. It is assumed that, in hot regions, the high temperatures expected throughout the 21st century may affect exterior cladding. For this reason, the study of historical plasterwork of great heritage value located in a warm region is addressed. The chosen case study is the Real Alcázar of Seville (RAS) and was based on the following aspects: (i) the annual monitoring of the environmental parameters T and RH, (ii) the estimation of hourly values in future scenarios using artificial intelligence and (iii) the use of the threshold values for the conservation of plasterwork defined in the literature.

2. METHODOLOGY

The methodological framework of this research is summarized in Fig. 2. As it can be seen, in this study a measurement process was carried out of an external point of the case study, while the external climate of the city was also monitored. Through these two approaches, the estimates for the years 2050 and 2080 were obtained using different methods. All these sets of environmental data were analyzed to evaluate the conservation risk of the historic plasterwork of the RAS.

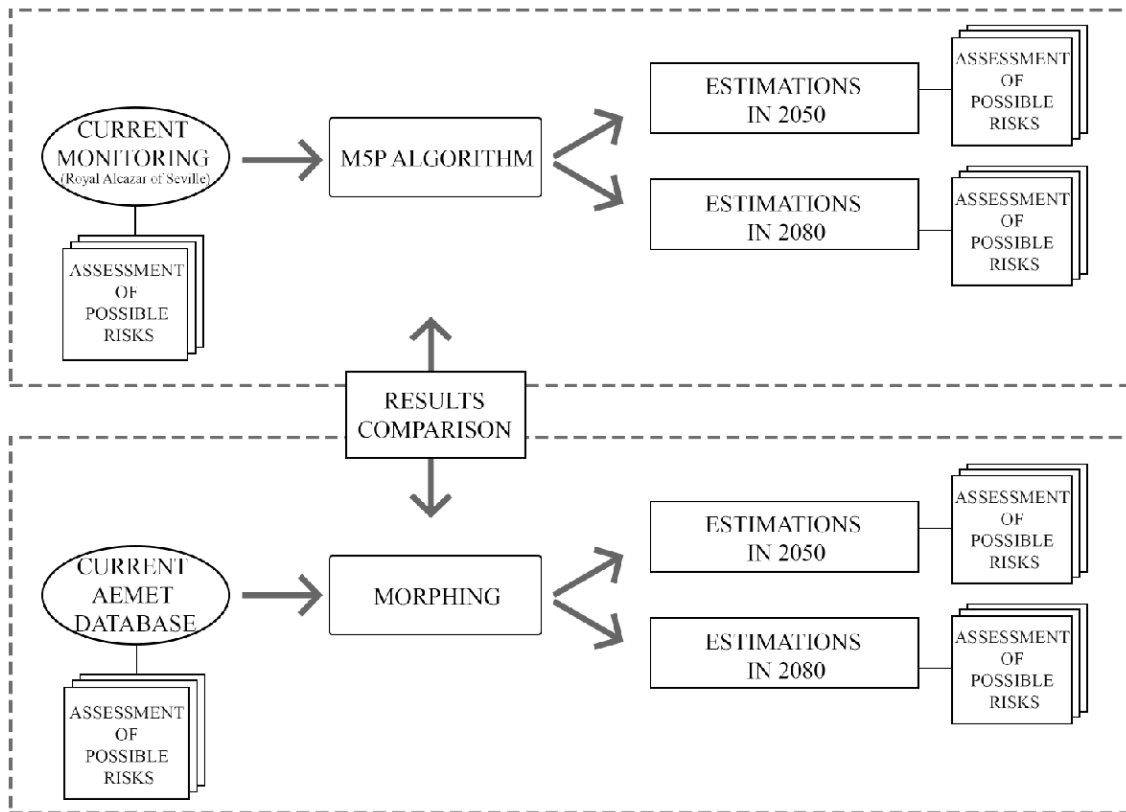

Fig. 2. Flowchart of the steps followed in the study.

2.1 Case study: The Palace of Pedro I (Real Alcázar of Seville)

The RAS was considered an Asset of Cultural Interest by the Spanish state in 1831¹ and declared a World Heritage Site by UNESCO in 1987². The complex is composed by different buildings built between the 10th and 18th centuries, among which the Palace of Pedro I (1356-1366) stands out [45] for the compositional richness of its decorations such as plasterwork [2] [3], ceramic tiles [4] [49] and carpentry [50,51] (Fig. 3).

¹ RI-51-0001067 according to Law 16/1985, of June 25, on Spanish Historical Heritage

² <http://whc.unesco.org/en/list/383> (Viewed in March 2021)



Fig. 3 Images of the Palace of Pedro I: (A and B) Courtyard of the Dolls, (C) Bedroom of the Moorish Kings, (D) Courtyard of the Maidens.

Environmental conditions have a direct influence on the conservation of materials, favoring degradation processes over time. In the case of plasterworks, the alterations are mainly manifested on the surface, which is the physically and mechanically weakest area, favoring deterioration, loss of material and the appearance of stains (Fig. 4). **Moisture defects are caused by physical mechanisms**, causing bulging, blisters, detachments, stains and even erosions and fissures. But moisture, normally infiltrated, develops a synergistic effect with chemical agents that gives rise to the appearance of injuries, as it can dissolve certain soluble salts contained in plasterwork, transporting them to the outside, evaporating the water in contact with the lower vapor pressure atmosphere and recrystallizing the salts, leading to efflorescence and crypto-efflorescence [29].



Fig. 4 Deterioration in RAS plasterwork: water seepage (A), direct action of rain (B), detachment after oxidation of the metallic element (C), disintegration of the material (D).

This work aims to establish a relationship between the environmental parameters (T - RH) and the preservation of historical plasterwork that allows to easily detect if the conditions of conservation for the material are optimal or not, and to know how they have influenced, and how they are influencing the process of degradation of the plasterwork. The study focuses on the Courtyard of the Maidens - the ground floor of the Palace of Pedro I- because there is the largest sample of plasterwork and the oldest since some are from the 14th century [52]. A complete characterization of these plasterworks and their polychromies could be found on previous works by other authors [46,47].

Additionally, the preventive conservation of the heritage is evaluated in future climate scenarios for the specific case of study and, once the climate model has been calibrated, it could be extrapolated to analogous climates to evaluate the long-term projection of the climatological conditions and its possible influence on the conservation of the plasterwork.

The control and regulation of environmental parameters within a reference interval around average values or typical seasonal cycles of the historical RAS climate will reduce the risk of physical-mechanical damage and will also allow to establish mitigation actions.

On the ground floor of the Palace, the interior areas are not physically closed by carpentry or locksmiths and are permanently open; there are large access arches that allow transit between different rooms, as well as between these and the outdoor spaces.

In this way, two areas according to exposure to environmental conditions could be defined. An area that includes those plasterworks that receive direct incidence of solar radiation has been considered (yellow zone) (Fig. 5-A), and another zone with those plasterworks not exposed to direct sunlight and with a higher relative humidity (red zone), being the most representative and unfavorable case in terms of the environmental parameters (Fig. 5-B).

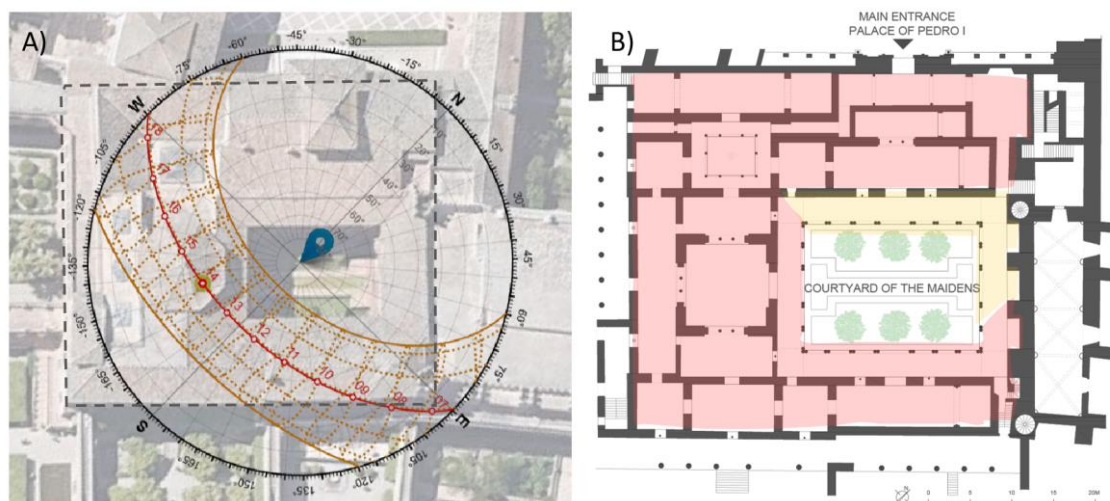

Fig. 5 A) Solar path on 03/20/2020 in the geographical coordinates corresponding to the Palace of Pedro I (Retrieved from <https://www.sunearthtools.com/>) B) Two different zones on the ground floor of the Pedro I Palace according to sunlight.

Additionally, it has been possible to verify that the humidity and temperature values measured in the interior rooms of the Palace of Pedro I [36] are very similar to those obtained in the southeast gallery of the Courtyard of the Maidens (exterior) because this area does not receive the direct incidence of solar radiation (Fig. 5-A).

2.2. Measurement procedure

To determine ambient temperature and relative humidity conditions, a Lascar thermohygrometer, model EL-USB 2 LCD with two recording channels, within the range -35°C to 80°C and 0% RH to 100% RH, with a resolution of $\pm 0.5^{\circ}\text{C}$ and $\pm 3\%$ RH was used.

In this case, the measurements have been carried out over a period of one year, at uninterrupted one-hour intervals from March 2020 to February 2021 with a thermo-hygrometer placed in the southeast gallery of the Courtyard of the Maidens (Fig. 6).

The outdoor measurements were obtained through the AEMET (State Meteorological Agency in Spain). The meteorological station used was the one located in Seville. This meteorological station is equipped with a VAISALA HMP45D probe with a measuring range from -40 to 60°C and -0.8 to 100% RH, and an accuracy of $\pm 0.2^{\circ}\text{C}$ and $\pm 2\%$ RH. The measurement data obtained are also from one-hour intervals.

To determine the interval of variation of RH by months, the average of the minimum and maximum daily humidities has been calculated and the monthly arithmetic means of these values have been obtained. These data have been studied following the indications of the UNE-EN 15757: 2011 standard[9].

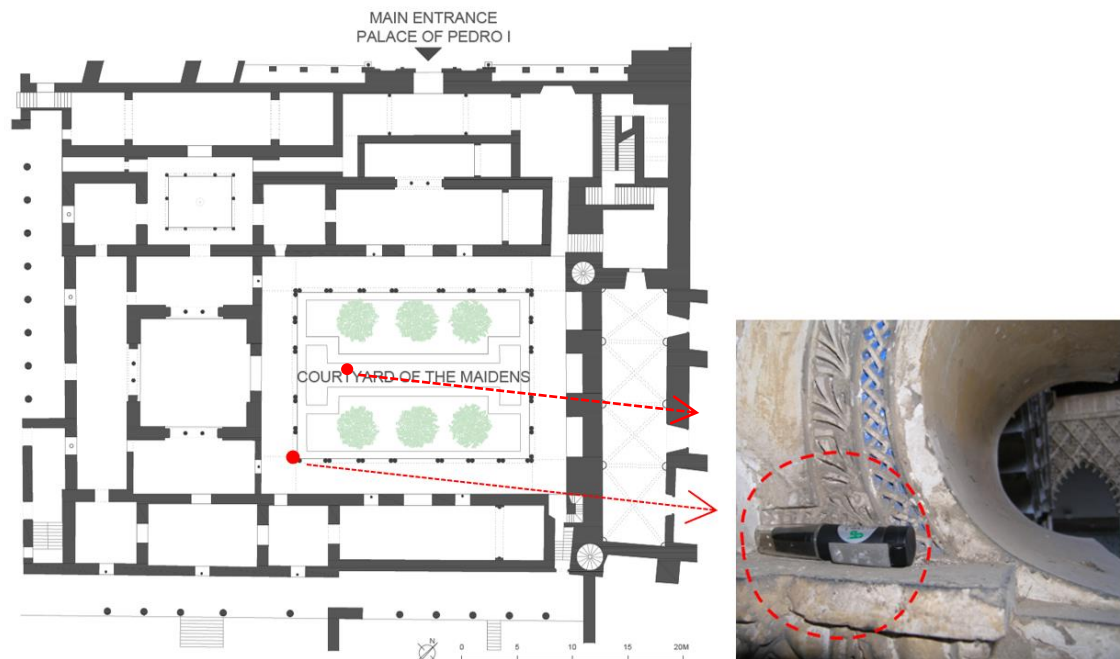

Fig. 6 Location of the monitoring equipment on the ground floor of the Pedro I Palace.

2.3. Obtaining future climate data

According to the data obtained during the annual monitoring, two approaches have been carried out to obtain future time series: (i) estimation of future outdoor climate data through the EPW morphing process of the climate zone of the case of study, and (ii) the estimation of the time series of the interior point through the application of data mining algorithms.

2.3.1. Morphing from the EPW of the climate zone of the case study

The first of them was based on the climatic files provided by the Spanish Technical Building Code (CTE)[53] for the climate zone of Seville, Csa (Mediterranean) according to Köppen – Geiger classification [54]. In the first place, T and RH data resulting from the monitoring have been entered in the Seville climate archive to be able to carry out the evaluation of future scenarios. Secondly, T and RH data measured outdoors have been compared with those existing in the CTE to see if it is feasible to establish considerations, not only in the case of study but also in plasterwork in similar "subtropical dry-summer" climates. The calibration criteria of the Federal Energy Management Program (FEMP)[55], ASHRAE GUIDELINE Standard 14-2002

[56], [57] and the International Performance Measurement and Verification Protocol (IPMVP) [58] have been followed. This validation process makes it possible to verify if the results of the estimations for the climate zone of Seville are related to the real values monitored with a margin of error. For this, the following formulas are used:

$$MBE = \frac{\sum_{i=1}^n (m_i - s_i)}{n} \quad (1)$$

$$MBE = \frac{\sum_{i=1}^n (m_i - s_i)}{n} \quad (2)$$

$$NMBE = \frac{1}{\bar{m}} \cdot \frac{\sum_{i=1}^n (m_i - s_i)}{n-p} \quad (3)$$

In order to scale the results of the Mean Bias Error (MBE) (Equation 1), Normalized Mean Bias Error (NMBE) is used by dividing MBE by the mean of measured values (\bar{m}), giving the global difference between the real values and the predicted ones (Equation 2); In these equations m_i is the measured value, s_i is the simulated one and n the number of measured data points. The Coefficient of Variation of the Root Mean Square Error CV (RMSE) measures the variability of the errors between measured and simulated values (Equation 3).

The limit values associated with these parameters vary depending on whether they are hourly or monthly. Considering that the environmental variables are hourly, the limit values are between -10% and 10% in NMBE and less than 30% in CV (RMSE) [56,57].

To estimate future climate scenarios in the climate zone, the CCWorldWeatherGen tool from the UK Met Office Hadley Center Coupled Model 3 HadCM3 has been used. Through a morphing process, this tool generates weather files adapted to climate change from any location in the world and creates files compatible with most building performance simulation programs [59]. The morphing of the climate files has been carried out for scenario A2 of greenhouse gas emissions according to the IPCC [60], resulting in climate scenario files for years 2050 and 2080.

2.3.2. Estimation of future time series of the case study

The data mining approach of this study was performed using the M5P algorithm. This algorithm allows estimating the time series for the years 2050 and 2080 in the measured interior point of the case study. The M5P algorithm (also known as M5') is an evolution of the Classification and regression tree (CART) [61,62]. Unlike CART, M5P combines decision trees with multivariate regression; a decision tree is built following the same inverted tree structure offered by CART, but a multiple linear regression (MLR) model is fitted on each sheet (Equation 4). Therefore, the algorithm works by developing an MLR model in each subregion (Fig. 7). In the process of developing the M5P algorithm tree, instead of maximizing the information gain, the internal variation of the subsets for the class values of each branch is minimized. Once the model is built, pruning reduces overfitting. The advantages of the models generated by this algorithm are that they efficiently handle large amounts of numerical variables and are robust in the absence of values in the instances of the analyzed dataset [63,64]. Thus, its use for the characterization of different aspects of buildings has increased in recent years [65,66].

$$\hat{Y}_{MLR} = \beta_0 + \sum_{i=1}^p (\beta_i x_i) + \varepsilon \quad (4)$$

Where β_0 is the independent term, β_i are the regression coefficients, x_i are the predictor variables, and ε is the error.

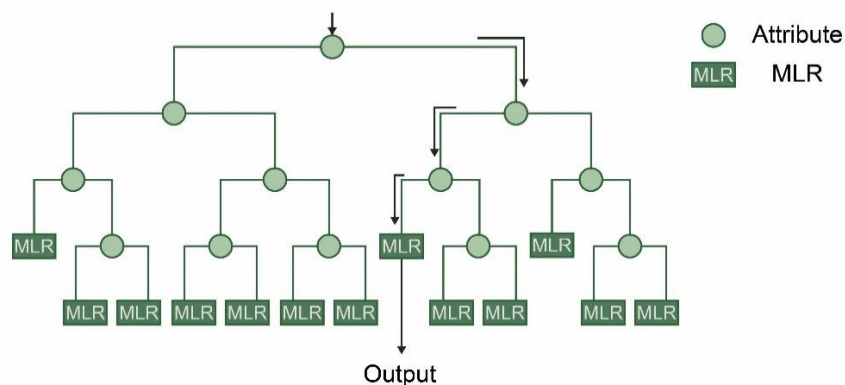

Fig. 7. Scheme of an M5P model.

The approach designed had a configuration of 6 input variables corresponding to the hourly values of temperature, relative humidity, dew point temperature, horizontal infrared radiation intensity, global horizontal radiation, and direction normal solar irradiance, diffuse horizontal solar irradiance of the time series of the outer point of Seville. The output variables correspond to the relative humidity and the temperature at the interior point of the case study. For each output variable a different M5P was designed.

The training of each M5P model was carried out using the data from the current scenario. Once the models were trained, time series of the years 2050 and 2080 were estimated. It is worth noting that the M5P models were validated using the coefficient of determination and the MBE index as statistical parameters.

3. RESULTS AND DISCUSSION

3.1 Thermo-hygrometric conditions of the Palace of Pedro I

The results obtained from the monitoring carried out between March 2020 and February 2021 in the southeast gallery of the Courtyard of the Maidens are shown in Fig. 8 and table 1:

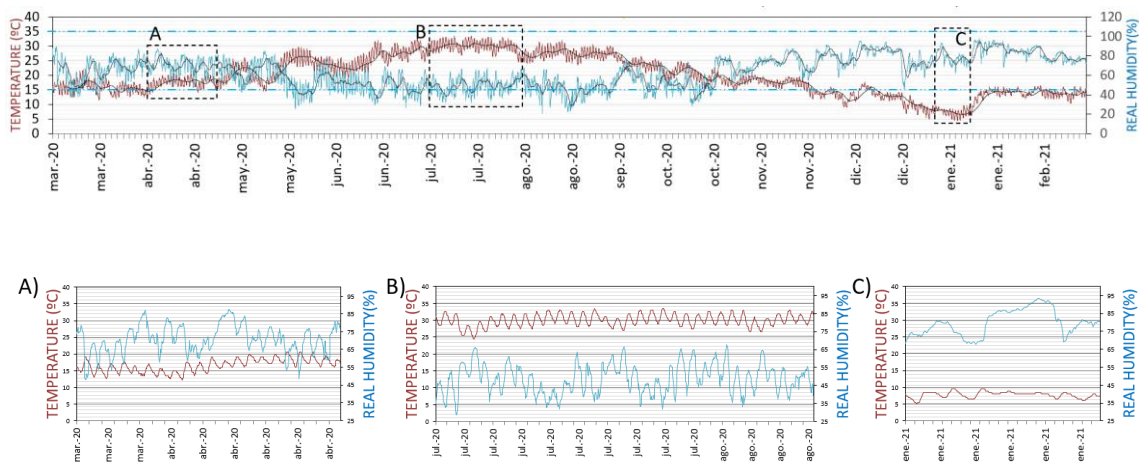

Fig. 8 Environmental conditions in the southeast corner of the Courtyard of the Maidens from March 2020 to February 2021.

The measurement of the T and RH parameters is relevant mainly for the study of the fluctuations and thermal jumps that may occur during the day-night hours or during the different seasons of the year. In this regard, it is observed that the most pronounced thermal jumps between day and night hours do not exceed 5°C (July and August), a fact that -by itself-

does not represent any risk in terms of material expansion. Finally, a high RH in winter is recorded and must be controlled with adequate ventilation, although it is within the acceptable range for the correct preservation of plasterwork.

Table 1. Summary of environmental parameters from 01/03 /2020 to 28 / 02/2021.

Months	RELATIVE HUMIDITY (%)					TEMPERATURE (° C)				
	Min. Values registered		Max. values registered		Δ (max-min)	Min. Values registered		Max. values registered		Δ (max-min)
	Average	SD	Average	SD		Average	SD	Average	SD	
Feb 20	55.3	11,001	73.8	9,454	18.5	14	1,319	18.1	1,577	4.1
Ap. 20	60.6	6,672	77.7	4,79	17.1	15.7	1,534	19.2	1,558	3.5
May 20	43.3	10,818	64.1	9,947	20.8	21.3	2,337	26.1	2,832	4.8
Jun 20	41.4	5,608	62	7,87	20.6	22.3	2,434	27.3	2,314	5
Jul. 20	38	5,877	56	7,43	18	27.6	1,448	31.8	1,328	4.2
Aug. 20	38	8,637	56.5	7,966	18.5	26.3	1,675	30.5	1,581	4.2
Sept. 20	44.1	9,493	58.3	8,287	14.2	24	1.9	27.4	2,105	3.4
Oct. 20	49.3	12,985	63.1	11,674	13.8	18.1	1,996	21.3	2,136	3.2
Nov. 20	70	8,459	78.6	7,134	8.6	15.6	1,964	17.9	1,965	2.3
Dec. 20	74.2	10,822	84.4	8,133	10.2	11.4	2,366	13.7	1,935	2.3
Jan. 21	75.2	9,545	86.1	8,141	10.9	8.6	3,493	11.2	3,093	2.6
Feb. 21	77.4	5,562	83.1	5,129	5.7	12.9	1,127	15.1	0,854	2.2

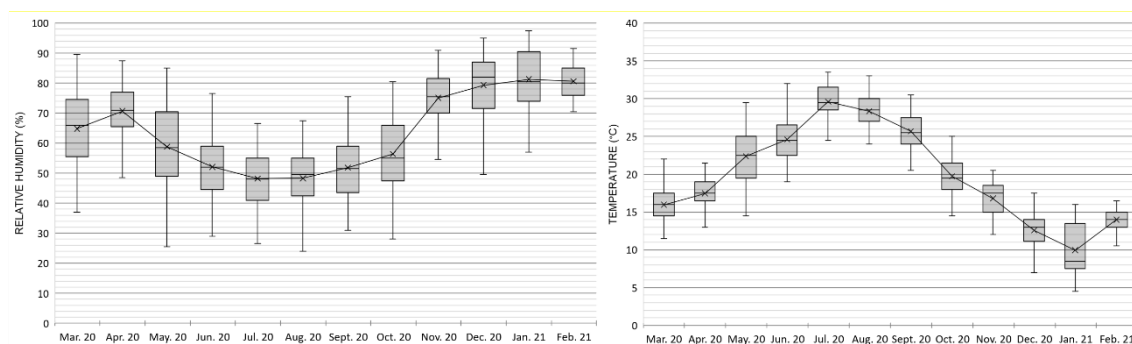

Fig. 9 Graphical representation of ambient condition (T and RH) from 01/03 /2020 to 28 / 02/2021.

From a detailed analysis of the measurements obtained (Table 1 and Fig 9), the risk due to high RH is concentrated from November to February, both inclusive; being January the most unfavorable month since 27.02% of the measurements recorded during that month exceed the limit of 90% RH. Likewise, the risk of dehydration of the gypsum and transformation into bassanite ($\text{CaSO}_4 \cdot 1/2\text{H}_2\text{O}$) occurs from May to October, both inclusive; being July and August

the most critical months for such purposes. It is worth to highlight that a 56.71% of the measurements recorded in the year remain below the limit established in the matrix (Fig. 10).

The data obtained correspond to a total of 8,760 measurements, of which only 11.76% are outside the limits established in the matrix that relates thermo-hygrometric conditions with the mineralogical phases of calcium sulfate, depending on their degree of hydration.

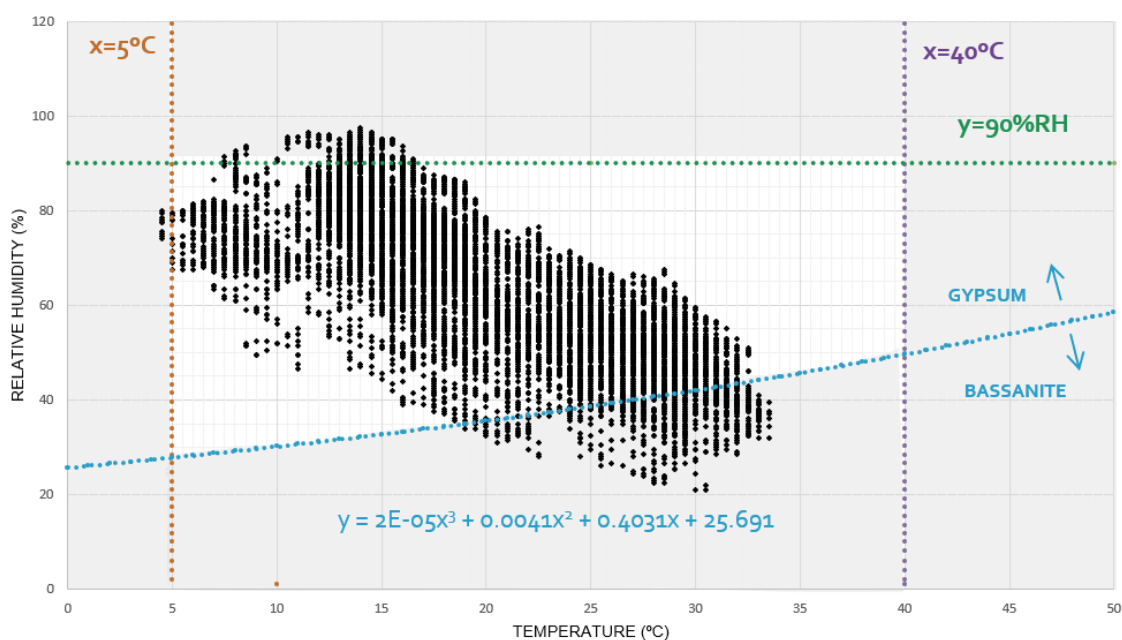

Fig. 10 Dispersion graph of the measurements from 01/03 /2020 to 28 / 02/2021 at the southeast corner of the Courtyard of the Maidens.

Regarding the type of risk detected, it can be seen in Fig. 10 how it is mainly distinguished between risk due to internal structural transformations (associated with the summer months) and risk due to high RH (associated with the winter months). The 7.95% of the hourly records correspond to measurements that are below the curve established by Winkler& Wilhelm [31], while the risk due to a high RH corresponds to 3.65% and the risk due to a low T corresponds to only 10 observations throughout the year, so the current climatic conditions in the Courtyard of the Maidens are favorable in this sense.

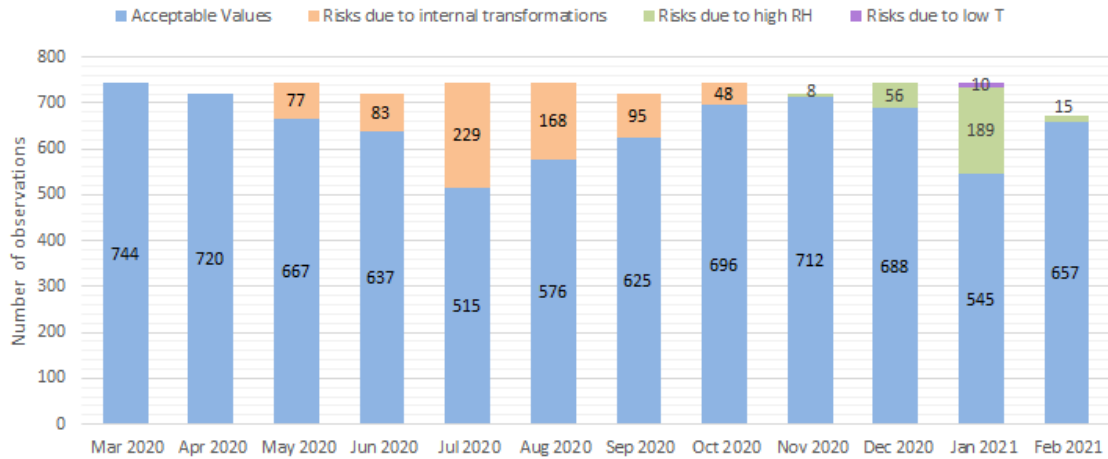

Fig. 11 Monthly representation of the hourly measurements obtained in the Courtyard of the Maidens from March 2020 to February 2021.

However, the results obtained from monitoring the climate of the city of Seville show different trends in conservation risks (Fig. 11). As it can be seen, although the most prominent risks are once again that of internal transformations in summer and high RH in winter, there is a greater number of observations that remain within these risks. Thus, the observations at risk of internal transformations correspond to values between 348 and 360 in July and August, while in the Courtyard of the Maidens the values were 229 and 168, respectively. Likewise, it was also detected how the risk due to high RH extends to a greater number of months than in the case of the Courtyard of the Maidens and with a significantly higher number of observations.

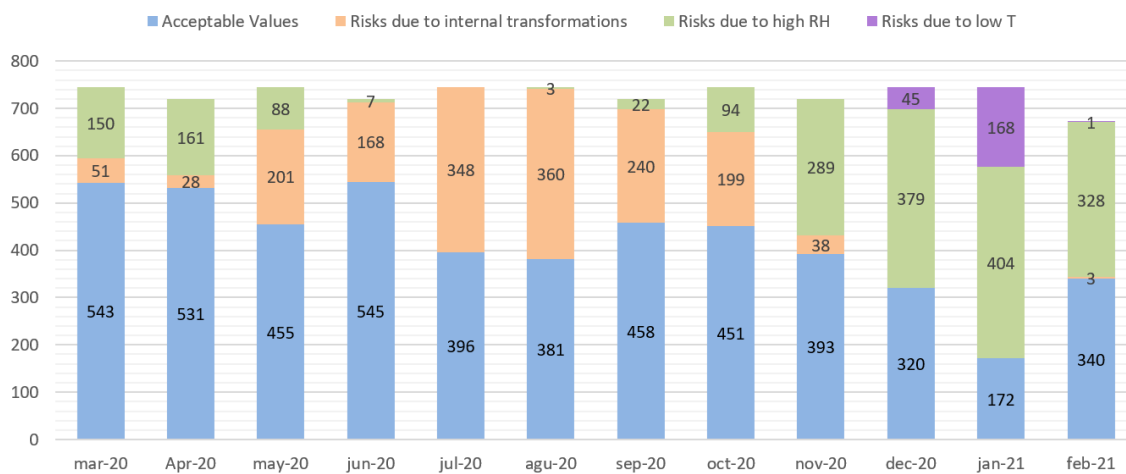

Fig. 12 Monthly representation of the hourly measurements obtained in Seville from March 2020 to February 2021.

Therefore, significant variations are detected in the results obtained with the two approaches. While the approach to the analysis of the Courtyard of the Maidens point (with a clear microclimate) presents less severe conditions for the conservation of plasterwork, outside the conditions would be different, presenting a greater risk due to the climate in these elements. Likewise, the variability detected between the two approaches shows the great variation that the analysis approaches of the influence of climate can present on the conservation of plasterwork. Thus, the use of a joint approach to the outdoor climate and microclimates in this type of case study allows us to show a broader perspective of the risk of conservation of plasterwork.

3.2 Calibration of outdoor measurements. The climate file of Seville.

Despite the possible risks detected in the current scenario, climate change can generate a change in the conservation conditions of plasterwork. For that, the future time series for the two previously validated approaches used were estimated in this study. In the case of the outdoor climate approach, T and RH parameters measured during the outdoor monitoring are compared with T and RH data extracted from the CTE for the climate zone of Seville Csa (Mediterranean). As the environmental variables analyzed are hourly, the limit values are between -10% and 10% in NMBE and less than 30% in CV (RMSE). According to Table 2, it is detected that the CV (RMSE) values are within the established error limits. However, it is detected that T is slightly higher (0.88%) than the limits in the NMBE and in matters related to RH the value exceeds the limit in the NMBE by 6.40% (Table 2). From these results we can establish the following considerations:

In the first place, considering that a measurement is being compared under specific environmental conditions **with a typical meteorological year** according to the criteria established in the CTE and based on the available meteorological stations, the level of approximation is good, especially if we consider the CV (RMSE).

Table 2. Calibration of measured data in RAS compared to CTE. Limit values according to ASHRAE Guideline14.

Variable	NMBE [%]		CV (RMSE) [%]	
	Obtained values	Limit values	Obtained values	Limit values
Temperature (T)	11.03	± 10	25.34	30
Relative humidity (RH)	15.52	± 10	27.08	30

Therefore, to make predictions for climate scenarios on the case study, it is necessary to use the actual measured values of T and RH. However, in order to establish considerations on similar Csa dry-summer subtropical or Mediterranean climates, we can consider the approximation to the real measurements as acceptable, recommending the verification of the specific microclimatic conditions using procedures similar to the one used.

In the case of the interior point approach, future estimates were obtained by M5P algorithm. Table 3 shows the values associated with each M5P model, while Fig. 13 shows the cloud of points between the actual and estimated values of the training and validation phase. As it can be seen, the coefficient of determination ranged between 74% and 87%, while the mean error ranged between 2.6°C and 8% RH in each variable. The estimates were more limited in the RH variable in a similar way to that detected in other studies for estimating future time series of RH [14]. In any case, the results can be considered valid to have a knowledge of the future time series expected in the addressed case study.

Table 3. Performance obtained by the M5P models in the training and validation phase.

Approach	Output variable	Determination coefficient (R ₂)	MBE
M5P 1	Temperature (T)	86.53%	2.6
M5P 2	Relative Humidity (RH)	74.93%	8.0

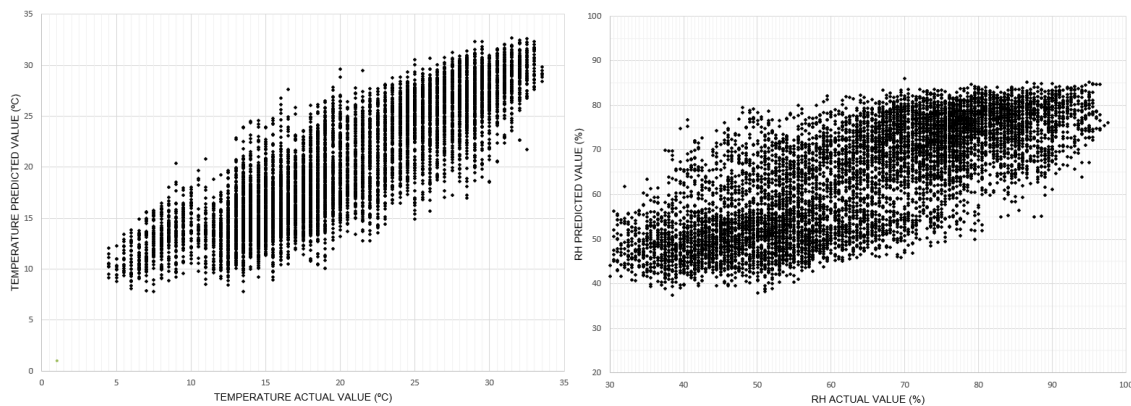

Fig. 13 Point clouds between the actual and estimated values in the training and validation phase.

3.3. Forecast of ambient temperature and humidity conditions in 2050 and 2080

Estimates of the time series in 2050 and 2080 of the two approaches make it possible to analyze the conservation risk in plasterwork with respect to the thresholds used in this study (Fig. 14). It can be seen how the behavior of the time series are different in both point clouds. While in the outdoor climate represents how the data are characterized by RH close to zero, in the case of the courtyard, higher lower values are detected. This can be seen more clearly with the values of the quartiles of the distributions. In the case of the exterior point in 2050, the minimum value of RH was 1% in 2050 and 2080, while in the Courtyard of the Maidens it was 19% in 2050 and 13% in 2080. Likewise, the quartiles show higher values in the Courtyard of the Maidens: (i) the first quartile (Q1) of the outer point obtained RH values of 34% in 2050 and 28% in 2080, while the inner point of the case study obtained values of 48% in 2050 and 45% in 2080; (ii) the second quartile (Q2) of the outer point obtained RH values of 49% in 2050 and 45% in 2080, while the inner point of the study case obtained values of 58% in 2050 and 54% in 2080; and (iii) the third quartile (Q3) of the outer point obtained RH values of 62% in 2050 and 60% in 2080, while the inner point of the study case obtained values of 71.5% in 2050 and 68.5 % in 2080.

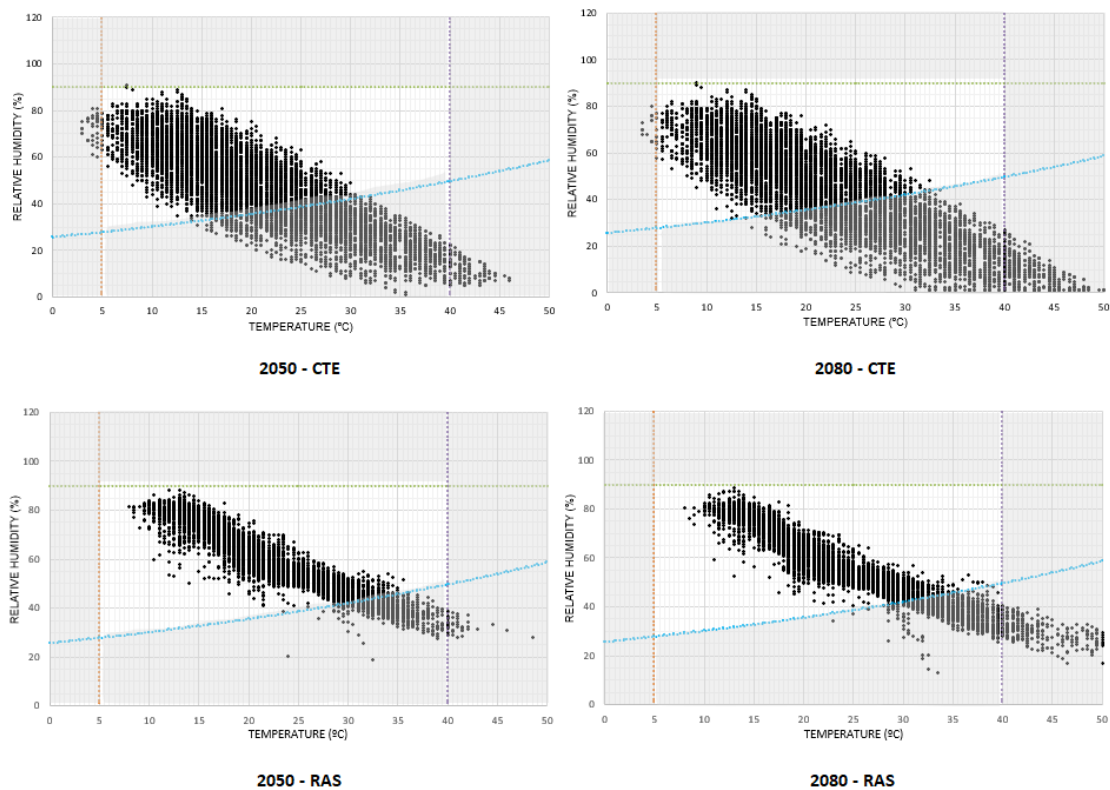

Fig. 14 Estimation of the climatic conditions of Seville (according to CTE) and RAS (own data in 2020 and estimation in 2050 and 2080 using M5P algorithm).

These variations in the time series distributions imply a different risk assessment in each combination of approach and year (Fig. 14), following the trends detected in the current scenario. Thus, the risk due to a very low RH indicated in Fig. 15 is corroborated. The results obtained by morphing the EPW reveal that the months with the lowest RH and highest ambient T will be August, September and October, leaving 99.58% of the estimates foreseen for the month of September 2080, below the optimal RH and at high ambient T. This risk due to high T combined with low RH is also appreciated in the estimation using the M5P but less accentuated and mainly framed in the months of June, July and August.

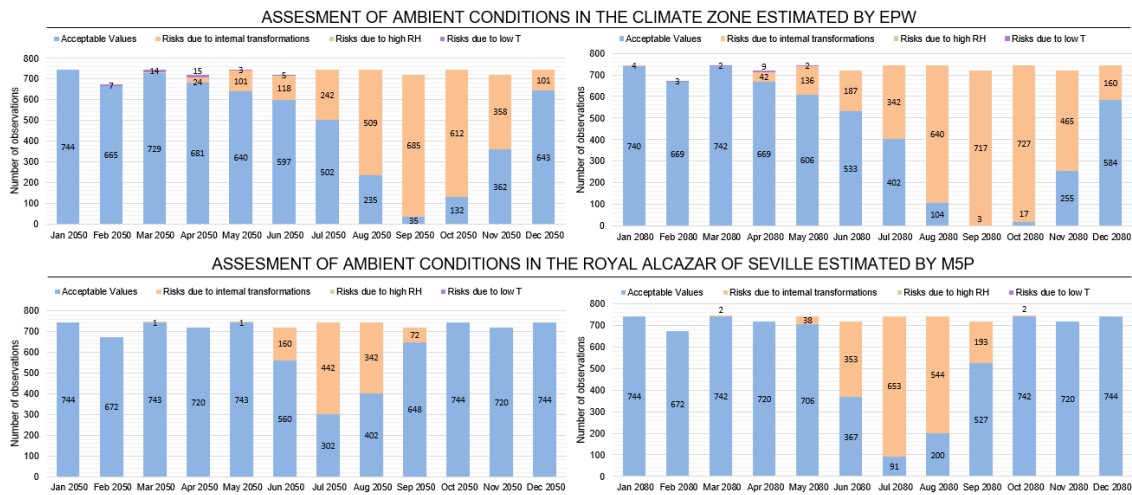

Fig. 15. Monthly representation of the risks obtained with the two approaches in future scenarios.

Thus, the results obtained indicate that the environmental conditions of the Mediterranean climate will tend towards a considerable increase in T that will be accompanied by lower RH, favoring the dehydration of materials such as plaster and the mechanical weakening of coatings in general. This trend is less pronounced in the case of the estimates obtained for the RAS because, although there is a slight increase in T, RH does not drop by 20%, which may be positive for the preservation of the plasterwork, as it would indicate that probably dehydration of the material occurs accompanied by its subsequent rehydration, maintaining mechanical performance[32].

In addition, the estimates obtained indicate that, over time, the appearance of humidity stains, the softening of the surface, the appearance of mold or the cracking of the polychromes of the RAS plasterwork, mainly caused by high HR, would be reduced. notably.

In any case, the differences obtained between the two approaches show the great variability that future estimates may obtain when evaluating the conservation risk in plasterwork. This aspect may mean that considering a single approach does not allow all possible behavioral scenarios to be encompassed. Thus, the joint analysis with climatic data in free field and with existing microclimate data in the case of study allows to know in detail the possible future ambient conditions. In this sense, the results obtained in free field could be representative for

the spaces in the study case that have plasterwork and do not have their own microclimate, such as the facade of the Palace of Pedro I. However, environments with a more unique microclimate, such as the Courtyard of the Maidens, may have different variations in the level of conservation.

4. CONCLUSIONS

This paper highlights that the impact of climate change on architectural heritage must be considered in the long-term management of the RAS. Plasterwork executed in the 14th century may not withstand future extreme climate conditions and risks associated with climate change should, therefore, be identified and quantified to facilitate relevant preservation measures. A long-term strategy to adapt to climate change must be based on risk assessment, adaptation measures, and monitoring. In this way, advanced simulations can be used to predict the future ambient conditions and its effect not only on historic buildings but also on plasterwork. However, due to the high degree of uncertainty in simulations, this approach is not sufficient.

This study establishes limits within a matrix that indicate the optimal conditions for better preservation of historical plasterwork. According to the obtained results based on the analysis of the environmental conditions (RH and T) during a period of one year with a frequency of 1h has allowed to verify that less than 12% of the measurements (n: 8760) exceed the limits of that matrix, not being a long-term exposure and, therefore, not assuming a risk for the preservation of the material.

The measurements have been compared with those collected by the CTE (B₄) and the AEMET and, by calculating the quadratic error, it has been possible to predict that the environmental conditions that will occur in the Pedro I Palace in future -years 2050 and 2080 - will be, a priori, favorable for the preservation of historical plasterwork. The data allow us to foresee a greater

number of periods of high temperatures and low relative humidity; however, it has been estimated that the mechanical performance of the material would not be significantly affected by dehydration processes due to they are not long-terms periods. The long-term climate data matrix obtained makes it possible to clearly establish that the climatic conditions inside the building are significantly more favorable than those outside, with a lower risk of alteration due to dehydration of the plaster.

Although the climatic conditions are not particularly severe in their impact on plasterwork, there is a clear trend towards more unfavorable conditions in certain periods of the year, which means that maintenance and preservation measures are planned for both, plasterwork and plaster mortar coatings of relevant buildings, in dry-summer subtropical climate.

The methodological process developed, which is based on periodical measurements which have been compared with data collected by the CTE (B4) and the AEMET, in order to establish a projection of long-term material performance may applied in the conservation intervention of the RAS and even in other similar buildings located in dry-summer subtropical climate. Results allow to establish an effective maintenance program that implies detailed review of each element, periodic reports of the controls and actions carried out and, specific corrective actions to fix mobile pieces or repair damage caused by external agents. This maintenance program and the meteorological data obtained in this work will also determine priority criteria for conservation and restoration interventions.

5. Disclosure statement

The authors have no conflicts of interest to declare.

6. Author contributions

All authors had full access to all the data and take responsibility for the integrity and the accuracy of the data analysis.

7. ACKNOWLEDGEMENTS

This research has been carried out thanks to the financing of the project "DEVELOPMENT AND EVALUATION OF DURABILITY MODELS AND PREVENTIVE CONSERVATION OF DECORATIVE ELEMENTS FROM THE HISTORICAL PLASTERS OF THE ROYAL ALCÁZAR DE SEVILLA" (PGC2018-093470-B-I00) by the Ministry of Science, Innovation and Universities of the Government of Spain and the financing received from the VI PPIT-2021-I.3 from the University of Seville.

The authors wish to thank the collaboration of the Board of Trustees of the Real Alcázar of Seville for the facilities provided to achieve visual inspection and measurement of environmental parameters.

8. REFERENCES

- [1] E. Lucchi, Review of preventive conservation in museum buildings, *J. Cult. Herit.* 29 (2018) 180–193. <https://doi.org/10.1016/j.culher.2017.09.003>.
- [2] D. Camuffo, *Microclimate for Cultural Heritage: Conservation, Restoration, and Maintenance of Indoor and Outdoor Monuments*, Elsevier, 2019.
- [3] I. Cook, R. Johnston, K. Selby, Climate Change and Cultural Heritage: A Landscape Vulnerability Framework, *J. Isl. Coast. Archaeol.* (2019). <https://doi.org/10.1080/15564894.2019.1605430>.
- [4] C. Ferreira, J. Barreiras, A. Silva, J. de Brito, I.S. Dias, I. Flores-Colen, Impact of environmental exposure conditions on the maintenance of facades' claddings, *Buildings*. 11 (2021). <https://doi.org/10.3390/buildings11040138>.
- [5] V. Costanzo, K. Fabbri, E. Schito, M. Pretelli, L. Marletta, Microclimate monitoring and conservation issues of a Baroque church in Italy: a risk assessment analysis, *Build. Res. Inf.* 0 (2021) 1–19. <https://doi.org/10.1080/09613218.2021.1899797>.
- [6] S.P. Corgnati, M. Filippi, Assessment of thermo-hygrometric quality in museums: Method and in-field application to the "Duccio di Buoninsegna" exhibition at Santa Maria della Scala (Siena, Italy), *J. Cult. Herit.* 11 (2010) 345–349. <https://doi.org/10.1016/j.culher.2009.05.003>.
- [7] M. Zarzo, A. Fernández-Navajas, F.J. García-Diego, Long-term monitoring of fresco paintings in the cathedral of Valencia (Spain) through humidity and temperature sensors in various locations for preventive conservation, *Sensors*. 11 (2011) 8685–8710. <https://doi.org/10.3390/s110908685>.
- [8] N. Italiana, UNI 10829. Works of art of historical importance. Ambient conditions for the conservation. Measurement and analysis. [Beni di interesse storico e artistico. Condizioni ambientali di conservazione. Misurazione ed analisi.], (1999) 1–24.

- [9] A.E. de N. UNE, UNE-EN 15757: Conservation of Cultural Property - Specifications for temperature and relative humidity to limit climate-induced mechanical damage in organic hygroscopic materials, (2011).
- [10] Ansi/Ashrae, ANSI/ASHRAE 55:2004 Thermal Environmental Conditions for Human Occupancy, Ashrae. (2004) 30.
- [11] PAS 198:2012 - Specification for managing environmental conditions for cultural collections – BSI British Standards, (n.d.). <http://shop.bsigroup.com/ProductDetail/?pid=00000000030219669>.
- [12] UNE-EN-15759-1, Conservation of cultural property. Indoor climate. Part 1: Guidelines for heating churches, chapels and other places of worship, (2012).
- [13] C. Bonacina, P. Baggio, F. Cappelletti, P. Romagnoni, A.G. Stevan, The Scrovegni Chapel: The results of over 20 years of indoor climate monitoring, *Energy Build.* 95 (2015) 144–152. <https://doi.org/10.1016/j.enbuild.2014.12.018>.
- [14] D. Bienvenido-Huertas, M. León-Muñoz, J.J. Martín-del-Río, C. Rubio-Bellido, Analysis of climate change impact on the preservation of heritage elements in historic buildings with a deficient indoor microclimate in warm regions, *Build. Environ.* 200 (2021) 107959. <https://doi.org/10.1016/j.buildenv.2021.107959>.
- [15] G. Zonno, R. Aguilar, R. Boroschek, P.B. Lourenço, Analysis of the long and short-term effects of temperature and humidity on the structural properties of adobe buildings using continuous monitoring, *Eng. Struct.* 196 (2019) 109299. <https://doi.org/10.1016/j.engstruct.2019.109299>.
- [16] R.P. Kramer, M.P.E. Maas, M.H.J. Martens, A.W.M. van Schijndel, H.L. Schellen, Energy conservation in museums using different setpoint strategies: A case study for a state-of-the-art museum using building simulations, *Appl. Energy.* 158 (2015) 446–458. <https://doi.org/10.1016/j.apenergy.2015.08.044>.
- [17] M. Napp, T. Kalamees, Energy use and indoor climate of conservation heating, dehumidification and adaptive ventilation for the climate control of a mediaeval church in a cold climate, *Energy Build.* 108 (2015) 61–71. <https://doi.org/10.1016/j.enbuild.2015.08.013>.
- [18] C. Cornaro, V.A. Puggioni, R.M. Strollo, Dynamic simulation and on-site measurements for energy retrofit of complex historic buildings: Villa Mondragone case study, *J. Build. Eng.* 6 (2016) 17–28. <https://doi.org/10.1016/j.jobbe.2016.02.001>.
- [19] T. Cardinale, G. Rospi, N. Cardinale, The influence of indoor microclimate on thermal comfort and conservation of artworks: The case study of the Cathedral of Matera (South Italy), in: *Energy Procedia*, Elsevier Ltd, 2014: pp. 425–432. <https://doi.org/10.1016/j.egypro.2014.10.398>.
- [20] A. Revi, D. Satterthwaite, F. Aragon-Durand, J. Corfee-Morlot, R. R. Kiunsi, M. Pelling, D. Roberts, W. Solecki, S.P. Gajjar, A. Sverdlík, Towards transformative adaptation in cities: the IPCC's Fifth Assessment, *Environ. Urban.* 26 (2014) 11–28. <https://doi.org/10.1177/0956247814523539>.
- [21] A.J. Prieto, K. Verichev, A. Silva, J. de Brito, On the impacts of climate change on the functional deterioration of heritage buildings in South Chile, *Build. Environ.* 183 (2020) 107138. <https://doi.org/10.1016/j.buildenv.2020.107138>.
- [22] V. Rajčić, A. Skender, D. Damjanović, An innovative methodology of assessing the

- climate change impact on cultural heritage, *Int. J. Archit. Herit.* 12 (2018) 21–35. <https://doi.org/10.1080/15583058.2017.1354094>.
- [23] A. Haugen, C. Bertolin, G. Leijonhufvud, T. Olstad, T. Broström, A methodology for long-term monitoring of climate change impacts on historic buildings, *Geosci.* 8 (2018). <https://doi.org/10.3390/geosciences8100370>.
- [24] S. Ramírez, M. Zarzo, A. Perles, F.J. García-Diego, A methodology for discriminant time series analysis applied to microclimate monitoring of fresco paintings, *Sensors (Switzerland)*. 21 (2021) 1–29. <https://doi.org/10.3390/s21020436>.
- [25] M. Gómez Heras, *La Temperatura en los Materiales del Patrimonio*, (2012) 87–95. <http://digital.csic.es/handle/10261/46794>.
- [26] Z. Pavlík, J. Fořt, R. Černý, An in situ monitoring system for the study of environmental influences on durability and the destructive process of building materials and structures, *WIT Trans. Modelling Simul.* 55 (2013) 287–296. <https://doi.org/10.2495/CMEM130231>.
- [27] S. Michalski, *Temperatura Incorrecta*, Can. Conserv. Institute. ICCROM. (2009).
- [28] S. Michalski, *Humedad relativa Incorrecta*, Can. Conserv. Institute. ICCROM. (2009).
- [29] L. Villanueva Domínguez, A. García Santos, *Manual del yeso*, CIE Inversiones Editoriales, 2001.
- [30] D. Freyer, W. Voigt, Crystallization and Phase Stability of CaSO₄ and CaSO₄ - Based Salts, *Monatshefte Fur Chemie.* 134 (2003) 693–719. <https://doi.org/10.1007/s00706-003-0590-3>.
- [31] E.M. Winkler, E.J. Wilhelm, Salt burst by hydration pressures in architectural stone in urban atmosphere, *Geol. Soc. Am. Bull.* 81 (1970) 567–572. [https://doi.org/https://doi.org/10.1130/0016-7606\(1970\)81\[567:SBBHPI\]2.o.CO;2](https://doi.org/https://doi.org/10.1130/0016-7606(1970)81[567:SBBHPI]2.o.CO;2).
- [32] L. Ritterbach, P. Becker, Temperature and humidity dependent formation of CaSO₄·xH₂O (x = 0...2) phases, *Glob. Planet. Change.* 187 (2020). <https://doi.org/10.1016/j.gloplacha.2020.103132>.
- [33] E. Goossens, Moisture transfer properties of coated gypsum, Technische Universiteit Eindhoven, Faculteit Bouwkunde, 2003. <https://doi.org/10.6100/IR571306>.
- [34] C.A.C. Mesquita, *Revestimientos Continuos Interiores de Varias Capas con Características de Barrera de Vapor e Higroscopicidad*, Doctoral dissertation, Polytechnic University of Madrid, 2012.
- [35] R. Rubio Domene, *Yaserías de la Alhambra. Historia, técnica y conservación*, Patronato de la Alhambra y Generalife. University of Granada, Granada, 2010.
- [36] M. Torres-González, F.J. Alejandro, V. Flores-alés, A.I. Calero-castillo, F.J. Blasco-lópez, Analysis of the state of conservation of historical plasterwork through visual inspection and non-destructive tests . The case of the upper frieze of the Toledanos Room (The Royal Alcázar of Seville , Spain), *J. Build. Eng.* 40 (2021) 1–14. <https://doi.org/https://doi.org/10.1016/j.jobbe.2021.102314>.
- [37] R. Campos de Alvear, The maintenance and the preventive preservation measures of the cultural goods in the Royal Alcázar of Seville, *Apunt. Del Alcázar Sevilla.* 18 (2018) 71–87.
- [38] E. Correa Gómez, R. Rubio Domene, El yeso. Las decoraciones de yeso en época nazarí, in: P. de la A. y Generalife (Ed.), *Man. Buenas Prácticas. Restauración Madera, Yeso y*

- Cerámica, Patronato, Consejería de Educación, Cultura y Deporte de la Junta de Andalucía, Granada, 2014: pp. 43–52.
- [39] J.M. Cabrera Garrido, La influencia de los contaminantes en el Patrimonio artístico Nacional, *Econ. Ind.* 107 (1972) 51–60.
- [40] H. Viitanen, T. Ojanen, Improved Model to Predict Mold Growth in Building Materials, in: *Therm. Perform. Exter. Envel. Whole Build. X–Proceedings CD*, 2007: pp. 2–7.
- [41] G.A. Tsongas, F. Rioroan, Minimum conditions for visible mold growth, *ASHRAE J.* 58 (2016) 32–43.
- [42] D. Sanz Arauz, Análisis del yeso empleado en revestimientos exteriores mediante técnicas geológicas, Doctoral dissertation, Universidad Politécnica de Madrid, 2009. http://oa.upm.es/17111/1/DAVID_SANZ_ARAUZ.pdf.
- [43] A.I. Calero Castillo, A. García Bueno, O. López Cruz, V.J. Medina Flórez, La policromía original de las yeserías del Patio de las Doncellas del Real Alcázar de Sevilla. Materiales constitutivos y técnicas de ejecución, *Arqueol. y Territ. Mediev.* 24 (2017) 255–290. <https://doi.org/10.17561/aytm.v24i0.9>.
- [44] C. Sabbioni, P. Brimblecombe, M. Cassar, *The Atlas of Climate Change Impact on European Cultural Heritage: Scientific Analysis and Management Strategies*, Anthem Press, London, UK, 2010.
- [45] A. Almagro Gorbea, El Alcázar de Sevilla Un palacio musulmán para un rey cristiano, in: *Cris. y Musulmanes En La Península Ibérica La Guerr. La Front. y La Convivencia. XI Congr. Estud. Mediev.*, 2007: pp. 331–365.
- [46] F.J. Blasco López, Yeserías medievales de tradición islámica del Real Alcázar de Sevilla: Revisión Historiográfica, Metodología para la caracterización, evaluación de su durabilidad y elaboración de un inventario, Doctoral dissertation, University of Seville, 2011.
- [47] A.I. Calero Castillo, Materiales, técnicas y procedimientos en la decoración arquitectónica. Aplicaciones a la conservación y restauración de las yeserías del Patio de las Doncellas. Real Alcázar de Sevilla., Doctoral dissertation, Universidad de Granada, 2016. <http://hdl.handle.net/10481/43864>.
- [48] A. Pleguezuelo, Tile-work in the mudéjar palace in the Royal Alcázar of Seville. A Preliminary Visual Analysis., *Apunt. Del Alcázar Sevilla.* 16 (2015) 219–230.
- [49] C. Enríquez Díaz, J.R. Baeza Álvarez, A project for the restoration of the tilings of the ground floor of the mudéjar palace, *Apunt. Del Alcázar Sevilla.* 19 (2019) 65–77.
- [50] C. Cañas Palop, Las armaduras de cubiertas mudéjares del palacio de Pedro I, del Alcázar de Sevilla: análisis integral y propuestas para la restauración, Doctoral dissertation, University of Seville, 2006. <https://dialnet.unirioja.es/servlet/tesis?codigo=23333>.
- [51] S. Fernández Aguilera, Portaventaneros mudéjares en el Real Alcázar de Sevilla, *Archivo Hi, Diputación Provincial de Sevilla, Sevilla*, 2012.
- [52] F.M. Tubino, Estudios sobre el arte en España. La arquitectura hispano-visigoda y árabe española. El Alcázar de Sevilla. Una iglesia mozárabe, 1886.
- [53] The Government of Spain, Royal Decree 314/2006. Approving the Spanish Technical Building Code, Madrid, Spain, 2013.
- [54] M. Kottek, J. Grieser, C. Beck, B. Rudolf, F. Rubel, World map of the Köppen-Geiger

- climate classification updated, *Meteorol. Zeitschrift.* 15 (2006) 259–263. <https://doi.org/10.1127/0941-2948/2006/0130>.
- [55] L. Webster, J. Bradford, *Measurement and Verification for Federal Energy (M&V Guidelines)*, 2008.
- [56] ANSI/ASHRAE, *ASHRAE Guideline 14-2002 Measurement of Energy and Demand Savings*, Ashrae. 8400 (2002) 170.
- [57] G.R. Ruiz, C.F. Bandera, *Validation of calibrated energy models: Common errors*, *Energies.* 10 (2017). <https://doi.org/10.3390/en10101587>.
- [58] Efficiency Valuation Organization, *International Performance Measurement & Verification Protocol*, *Handb. Financ. Energy Proj. I* (2016) 122.
- [59] M.F. Jentsch, A.S. Bahaj, P.A.B. James, *CCWorldWeatherGen*, *Climate change world weather file generator*, Version 1.8, *Sustain. Energy Res. Gr.* (2013).
- [60] I.P. on C. Change, *Summary for Policymakers*, in: *Intergovernmental Panel on Climate Change (Ed.), Clim. Chang. 2013 - Phys. Sci. Basis*, Cambridge University Press, Cambridge, 2014: pp. 1–30. <https://doi.org/10.1017/CBO9781107415324.004>.
- [61] J.R. Quinlan, others, *Learning with continuous classes*, in: *5th Aust. Jt. Conf. Artif. Intell.*, 1992: pp. 343–348.
- [62] Y. Wang, I.H. Witten, *Induction of model trees for predicting continuous classes*, in: *Eur. Conf. Mach. Learn.*, Prague: University of Economics, Faculty of Informatics and Statistics, 1997.
- [63] A. Behnood, V. Behnood, M. Modiri Gharehveran, K.E. Alyamac, *Prediction of the compressive strength of normal and high-performance concretes using M5P model tree algorithm*, *Constr. Build. Mater.* 142 (2017) 199–207. <https://doi.org/10.1016/j.conbuildmat.2017.03.061>.
- [64] L. Lin, Q. Wang, A.W. Sadek, *A combined M5P tree and hazard-based duration model for predicting urban freeway traffic accident durations*, *Accid. Anal. Prev.* 91 (2016) 114–126. <https://doi.org/10.1016/j.aap.2016.03.001>.
- [65] F. Afsarian, A. Saber, A. Pourzangbar, A.G. Olabi, M.A. Khanmohammadi, *Analysis of recycled aggregates effect on energy conservation using M5" model tree algorithm*, *Energy.* 156 (2018) 264–277. <https://doi.org/10.1016/j.energy.2018.05.099>.
- [66] C.F. Jeffrey Kuo, C.H. Lin, M.H. Lee, *Analyze the energy consumption characteristics and affecting factors of Taiwan's convenience stores-using the big data mining approach*, *Energy Build.* 168 (2018) 120–136. <https://doi.org/10.1016/j.enbuild.2018.03.021>.