

Quantum key distribution without alternative measurements

Adán Cabello*

Departamento de Física Aplicada, Universidad de Sevilla, 41012 Sevilla, Spain

(Received 29 October 1999; published 18 April 2000)

Entanglement swapping between Einstein-Podolsky-Rosen (EPR) pairs can be used to generate the same sequence of random bits in two remote places. A quantum key distribution protocol based on this idea is described. The scheme exhibits the following features. (a) It does not require that Alice and Bob choose between alternative measurements, therefore improving the rate of generated bits by transmitted qubit. (b) It allows Alice and Bob to generate a key of arbitrary length using a single quantum system (three EPR pairs), instead of a long sequence of them. (c) Detecting Eve requires the comparison of fewer bits. (d) Entanglement is an essential ingredient. The scheme assumes reliable measurements of the Bell operator.

PACS number(s): 03.67.Dd, 03.67.Hk, 03.65.Bz

The two main goals of cryptography are for two distant parties, Alice and Bob, to be able to communicate in a form that is unintelligible to a third party, Eve, and to prove that the message was not altered in transit. Both of these goals can be accomplished securely if both Alice and Bob are in possession of the same secret random sequence of bits, a “key” [1]. Therefore, one of the main problems of cryptography is the key distribution problem, that is, how do Alice and Bob, who initially share no secret information, come into the possession of a secret key, while being sure that Eve cannot acquire even partial information about it. This problem cannot be solved by classical means, but it can be solved using quantum mechanics [2]. The security of protocols for quantum key distribution (QKD) such as the Bennett-Brassard 1984 (BB84) [2], E91 [3], B92 [4], and other protocols [5,6], is assured by the fact that while information stored in classical form can be examined and copied without altering it in any detectable way, it is impossible to do that when information is stored in unknown quantum states, because an unknown quantum state cannot be reliably cloned (“no-cloning” theorem [7]). In these protocols security is assured by the fact that both Alice and Bob must choose randomly between two possible measurements. In this paper I introduce a QKD scheme which does not require that Alice and Bob choose between alternative measurements. This scheme is based on “entanglement swapping” [8–10] between two pairs of “qubits” (quantum two-level systems), induced by a Bell operator measurement [11]. The Bell operator is a nondegenerate operator which acts on a pair of qubits i and j , and projects their combined state onto one of the four Bell states

$$|00\rangle_{ij} = \frac{1}{\sqrt{2}}(|0\rangle_i \otimes |0\rangle_j + |1\rangle_i \otimes |1\rangle_j), \quad (1)$$

$$|01\rangle_{ij} = \frac{1}{\sqrt{2}}(|0\rangle_i \otimes |0\rangle_j - |1\rangle_i \otimes |1\rangle_j), \quad (2)$$

$$|10\rangle_{ij} = \frac{1}{\sqrt{2}}(|0\rangle_i \otimes |1\rangle_j + |1\rangle_i \otimes |0\rangle_j), \quad (3)$$

$$|11\rangle_{ij} = \frac{1}{\sqrt{2}}(|0\rangle_i \otimes |1\rangle_j - |1\rangle_i \otimes |0\rangle_j). \quad (4)$$

Entanglement swapping works as follows. Consider a pair of qubits, i and j , prepared in one of the four Bell states, for instance, $|11\rangle_{ij}$. Consider a second pair of qubits k and l prepared in another Bell state, for instance, $|01\rangle_{kl}$. If a Bell operator measurement is performed on i and k , then the four possible results “00,” “01,” “10,” and “11” have the same probability to occur. In fact, the outcome of each measurement is purely random. Suppose that the result “00” is obtained, consequently the state of the pair i and k after the measurement is $|00\rangle_{ik}$. Moreover, the state of j and l is projected onto state $|10\rangle_{jl}$. Therefore, the state of j and l becomes entangled although they have never interacted.

I will denote the initial state of the pairs i, j and k, l , in the previous example by $|11\rangle_{ij} \otimes |01\rangle_{kl}$, and the final state of the pairs i, k and j, l by $|00\rangle_{ik} \otimes |10\rangle_{jl}$. Suppose that the initial state of the pairs i, j and k, l is a product of two Bell states and, as in the previous example, a Bell operator measurement is executed on two qubits, one of each pair; then, after the measurement the state of the pairs i, k and j, l becomes a product of two Bell states. All possibilities are collected in Table I.

The proposed scheme for QKD is illustrated in Fig. 1 and it is described as follows.

(i) Consider six qubits numbered 1 to 6. Alice prepares qubits 1 and 2 in the Bell state $|11\rangle_{12}$, and qubits 3 and 5 in the Bell state $|10\rangle_{35}$. In a remote place, Bob prepares qubits 4 and 6 in the Bell state $|10\rangle_{46}$. All this information is public. 2 and 6 will be the only transmitted qubits during the process. Alice will always retain qubits 1, 3, and 5; and Bob will always retain qubit 4.

(ii) Alice transmits qubit 2 to Bob using a public channel. This channel must be a transmission medium that isolates the state of the qubit from interactions with the environment.

(iii) Alice secretly measures the Bell operator on qubits 1 and 3, and Bob secretly measures the Bell operator on qubits

*Electronic address: adan@cica.es

TABLE I. All possible results of a Bell operator measurement on qubits i and k . For example, if the initial state is $|11\rangle_{ij} \otimes |01\rangle_{kl}$, you must locate 1101 on the left half of the table. Then, after a Bell operator measurement on i and k , the four possible final states are represented on the right half of the table by 0010, 0111, 1000, and 1101; where, for instance, 0010 means $|00\rangle_{ik} \otimes |10\rangle_{jl}$.

Initial state $ ijkl\rangle$				Possible final states $ ijkl\rangle$			
0000	0101	1010	1111	0000	0101	1010	1111
0001	0100	1011	1110	0001	0100	1011	1110
0010	0111	1000	1101	0010	0111	1000	1101
0011	0110	1001	1100	0011	0110	1001	1100

2 and 4. The results of both experiments are correlated, although Alice and Bob do not know how as yet. The purpose of the next step is to elucidate how the results are correlated without publicly revealing either of them.

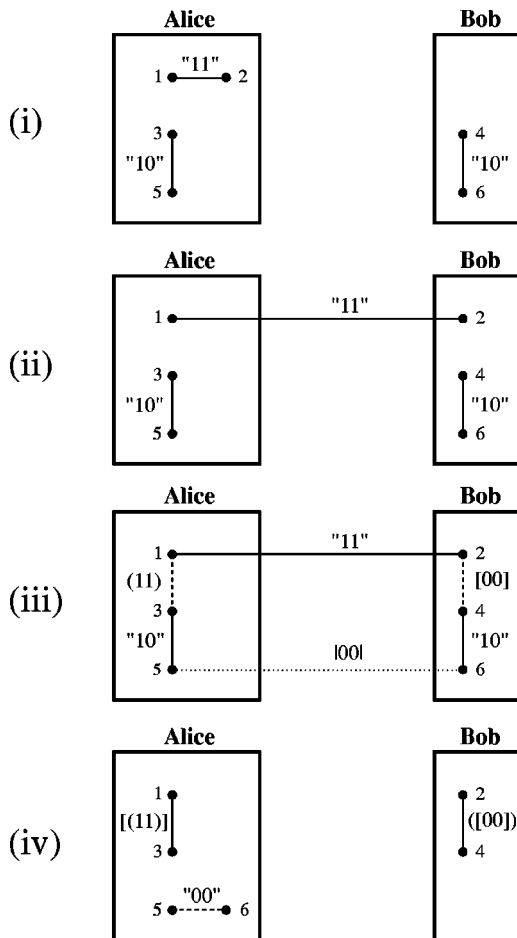

FIG. 1. QKD scheme based on entanglement swapping. The bold lines connect qubits in Bell states, the dashed lines connect qubits on which a Bell operator measurement is made, and the pointed lines connect qubits in Bell states induced by entanglement swapping. “00” means that the Bell state $|00\rangle$ is public knowledge, (00) means that it is only known to Alice, [00] means that it is only known to Bob, $|00\rangle$ means that it is unknown to all the parts, [(00)] means that it is only known to Alice and Bob, etc.

(iv) Bob transmits qubit 6 to Alice using a public channel. Then Alice measures the Bell operator on qubits 5 and 6, and publicly announces the result. Suppose that Alice has obtained “11” in her secret measurement on qubits 1 and 3. Then, since the initial state of 1, 2, 3, and 5 was $|11\rangle_{12} \otimes |10\rangle_{35}$, by using Table I Alice knows that the state of 2 and 5 is $|10\rangle_{25}$. In addition, suppose that Alice obtains “00” in the public measurement on 5 and 6. Then, since she knows that the previous state of 2, 4, 5, and 6 was $|10\rangle_{25} \otimes |10\rangle_{46}$, by using Table I Alice knows that Bob has obtained “00” in his secret measurement on 2 and 4. Following a similar reasoning, Bob can know that Alice has obtained “11” in her secret measurement on 1 and 3. Previously, Alice and Bob have agreed to choose the sequence of results of Alice’s secret measurements to form the key. The two initial bits of the key are therefore “11.” The public information shared by Alice and Bob is not enough for Eve to acquire any knowledge of the result obtained by one of the parts. Using this information Eve only knows that one of the following four possible combinations of results for Alice and Bob’s secret measurements have occurred: “00” for Alice’s result and “11” for Bob’s, “01” and “10,” “10” and “01,” and “11” and “00.”

One Bell state can be transformed into another just by rotating one of the qubits. Using this property, Alice (Bob) can change the Bell state of qubits 1 and 3 (2 and 4) to a previously agreed public state. Then the situation is similar to (i) and the next stage of the process can be started.

This scheme for QKD has the following features.

(a) It improves the rate of generated bits by transmitted qubit. In BB84 and in B92 (and in E91), Bob (and Alice) must choose between two alternative measurements in order to preserve security. This implies that the number of useful random bits shared by Alice and Bob by transmitted qubit, before checking for eavesdropping, is 0.5 bits by transmitted qubit, both in BB84 and B92 (and 0.25 in E91), or at the most, it can be made to approach 1 in Ref. [6]. In our scheme the rate is 1 bit by transmitted qubit. This is so because Alice and Bob always perform the same kind of measurement, a Bell operator measurement, and therefore, each of them acquires two correlated random bits after each stage of the process. In each of these stages, only two qubits are transmitted (one from Alice to Bob and another from Bob to Alice). This improvement is very useful since a key must be as large as the message to be transmitted (written as a sequence of bits), and cannot be reused for subsequent messages [1].

(b) It only requires a single quantum system (three EPR pairs) instead of a long sequence of quantum systems, to generate a key of arbitrary length. By contrast with previous schemes, in the one presented here no source of qubits is needed. The same two qubits (qubits 2 and 6) are transmitted to and from Alice and Bob over and over again [12].

(c) The detection of Eve requires the comparison of fewer bits. The transmitted qubits do not encode the bits that form the key, but only the type of correlation between the results of the experiments that allow Alice and Bob to secretly generate the key. Therefore, intercepting and copying them does not allow Eve to acquire any information about the key. In

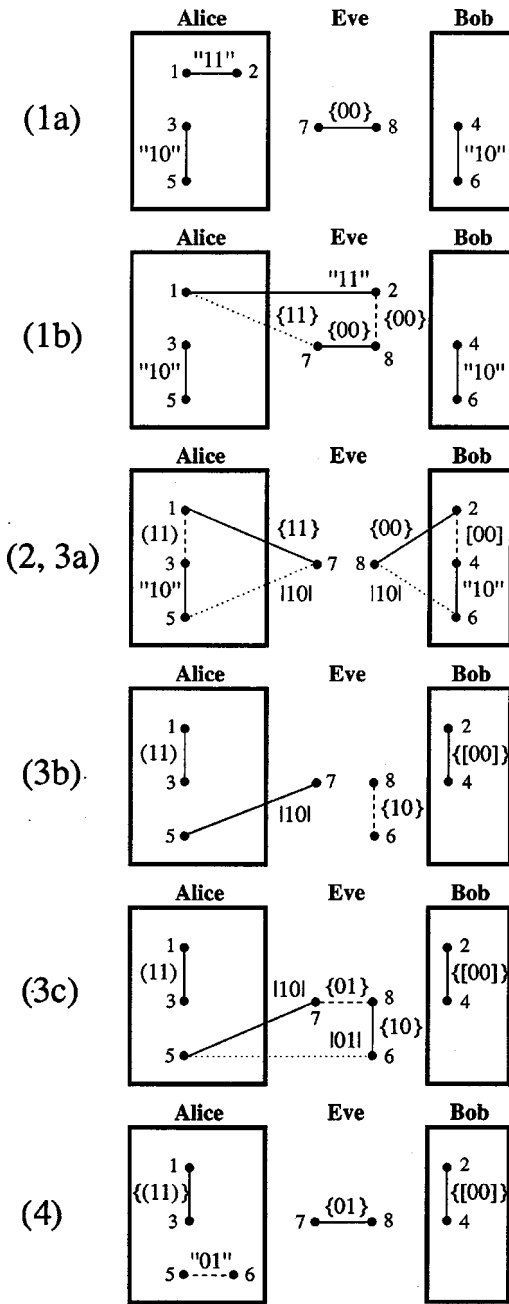

FIG. 2. Eve's strategy to obtain Alice's secret result. $\{00\}$ means that the Bell state $|00\rangle$ is only known to Eve. The remaining notation is the same as in Fig. 1.

fact, the state of the transmitted qubits is public. However, Eve can use a strategy—also based on entanglement swapping—to learn Alice's sequence of secret results. This strategy is illustrated in Fig. 2 and is described as follows.

(1a) Consider the same scenario as in (i) but suppose Eve has two additional qubits 7 and 8, initially prepared in a Bell state, for instance, $|00\rangle_{78}$.

(1b) Eve intercepts qubit 2 that Alice send to Bob and makes a Bell operator measurement on qubits 2 and 8. Then qubits 1 and 7 become entangled in a known (to Eve) Bell state. For instance, if after Eve's measurement the state of 2 and 8 is $|00\rangle_{28}$, then the state of 1 and 7 becomes $|11\rangle_{17}$.

(2) Therefore, after Eve's intervention the real situation is not that described in (ii). Now qubit 1 is entangled with Eve's qubit 7, and 2 is entangled with Eve's 8.

(3a) In this new scenario, after Alice's (Bob's) measurement on qubits 1 and 3 (2 and 4), the state of qubits 5 and 7 (6 and 8) becomes a Bell state. For instance, if Alice (Bob) obtains "11" ("00"), the state of qubits 5 and 7 (6 and 8) would be $|10\rangle_{57}$ ($|10\rangle_{68}$). However, these states are unknown to Eve, because she (still) does not know the results of Alice's and Bob's measurements.

(3b) Eve intercepts qubit 6 that Bob sends to Alice and makes a Bell operator measurement on qubits 6 and 8. This reveals the state they were in. Then Eve can know Bob's result. For instance, in our example, Eve would find "10" and would know that Bob's result was "00."

(3c) Eve makes a Bell operator measurement on qubits 7 and 8. Then qubits 5 and 6 becomes entangled in a Bell state (still) unknown to Eve, because she does not know Alice's secret result. For instance, if Eve obtains "01," then qubits 5 and 6 would be in the state $|01\rangle_{56}$.

(4) Eve gives qubit 6 to Alice. Alice makes a measurement on 5 and 6 and announces the result. Then Eve can know the previous state of 5 and 7 ($|10\rangle_{57}$, in our example) and the result of Alice's measurement on 1 and 3 ("11," in our example).

However, Eve's intervention changes the correlation that Alice and Bob expect between their secret results. For instance, in our example, Bob, using his result and the result publicly announced by Alice, thinks that the two initial bits of the key are "10."

As in previous QKD protocols, in our scheme Alice and Bob can detect Eve's intervention by publicly comparing a sufficiently large random subset of their sequences of bits, which they subsequently discard. If they find that the tested subset is identical, they can infer that the remaining untested subset is also identical, and therefore can form a key. In BB84, for each bit tested by Alice and Bob, the probability of that test revealing the presence of Eve (given that Eve is indeed present) is $\frac{1}{4}$. Thus, if N bits are tested, the probability of detecting Eve (given that she is present) is $1 - (\frac{3}{4})^N$. In our scheme if Alice and Bob compare a pair of bits generated in the same step, the probability for that test to reveal Eve is $\frac{3}{4}$. Thus if n pairs ($N=2n$ bits) are tested, the probability of Eve's detection is $1 - (\frac{1}{2})^N$. This improvement in the efficiency of the detection of eavesdropping has been pointed out for a particular eavesdropping attack, it would be interesting to investigate whether more general attacks exist and whether the improvement in efficiency is also present in these cases.

(d) It uses entanglement as an essential tool. QKD was the first practical application of quantum entanglement [3]. However, as shown in Ref. [13], entanglement was not an essential ingredient, in the sense that almost the same goals can be achieved without entanglement. However, subsequent striking applications of quantum mechanics such as quantum dense coding [14,15], teleportation of quantum states [8,16,17], entanglement swapping [8,9], and quantum com-

putation [18], are strongly based on quantum entanglement. The scheme described here relies on entanglement in the sense that it performs a task—QKD with properties (a), (b), and (c)—that cannot be accessible without entanglement.

The practical feasibility of the scheme described in this paper hinges on the feasibility of a reliable (i.e., with 100% theoretical probability of success) Bell operator measurement. Bell operator measurements are also required for reliable double density quantum coding and teleportation. As far as I know, the first proposals for a reliable Bell operator measurement are those which discriminate between the four polarization-entangled two-photon Bell states using en-

tanglement in additional degrees of freedom [19] or using atomic coherence [20].

It is not expected that the protocol for QKD introduced in this paper will be able to improve existing experiments [21] for real quantum cryptography in practice. Its main importance is conceptual: it provides a different quantum solution to a problem already solved by quantum mechanics.

The author thanks J. L. Cereceda, O. Cohen, A. K. Ekert, C. Fuchs, T. Mor, and B. Orfila for helpful comments. This work was supported by the Universidad de Sevilla (Grant No. OGICYT-191-97) and the Junta de Andalucía (Grant No. FQM-239).

-
- [1] The Vernam cipher or “one-time pad” [G.S. Vernam, *J. Am. Inst. Electr. Eng.* **45**, 109 (1926)] is the only known absolutely secure method for encrypting a message [C.E. Shannon, *Bell Syst. Tech. J.* **28**, 657 (1949)]. Alice writes the message as sequence of bits, and adds the key to it, bit by bit, modulo 2. The result is the “ciphertext,” which is publicly transmitted. Bob can recover the message by adding the key to the ciphertext, modulo 2. If the same key is used for a second message, Eve can obtain the addition modulo 2 of both messages just by adding their ciphertexts. If only a finite vocabulary is used in the messages, this is enough to reveal both of them.
- [2] C. H. Bennett and G. Brassard, in *Proceedings of IEEE International Conference on Computers, Systems, and Signal Processing, Bangalore, India* (IEEE, New York, 1984), p. 175.
- [3] A.K. Ekert, *Phys. Rev. Lett.* **67**, 661 (1991).
- [4] C.H. Bennett, *Phys. Rev. Lett.* **68**, 3121 (1992).
- [5] L. Goldenberg and L. Vaidman, *Phys. Rev. Lett.* **75**, 1239 (1995); **77**, 3265 (1996); A. Peres, *ibid.* **77**, 3264 (1996); T. Mor, *ibid.* **80**, 3137 (1998).
- [6] M. Ardehali, H.F. Chau, and H.-K. Lo, e-print quant-ph/9803007 (unpublished).
- [7] W.K. Wootters and W.H. Zurek, *Nature (London)* **299**, 802 (1982).
- [8] C.H. Bennett, G. Brassard, C. Crépeau, R. Jozsa, A. Peres, and W.K. Wootters, *Phys. Rev. Lett.* **70**, 1895 (1993).
- [9] M. Żukowski, A. Zeilinger, M.A. Horne, and A.K. Ekert, *Phys. Rev. Lett.* **71**, 4287 (1993); S. Bose, V. Vedral, and P.L. Knight, *Phys. Rev. A* **57**, 822 (1998); J-W. Pan, D. Bouwmeester, H. Weinfurter, and A. Zeilinger, *Phys. Rev. Lett.* **80**, 3891 (1998).
- [10] Entanglement swapping has been previously used in QKD for a different purpose, O. Cohen, *Helv. Phys. Acta* **70**, 710 (1997).
- [11] S.L. Braunstein, A. Mann, and M. Revzen, *Phys. Rev. Lett.* **68**, 3259 (1992).
- [12] Existing schemes for quantum key distribution can also work with a small numbers of qubits, as long as they are symmetrised so that in each round of the protocol Alice and Bob reverse their roles.
- [13] C.H. Bennett, G. Brassard, and N.D. Mermin, *Phys. Rev. Lett.* **68**, 557 (1992).
- [14] C.H. Bennett and J. Wiesner, *Phys. Rev. Lett.* **69**, 2881 (1992).
- [15] K. Mattle, H. Weinfurter, P.G. Kwiat, and A. Zeilinger, *Phys. Rev. Lett.* **76**, 4656 (1996).
- [16] D. Bouwmeester, J. Pan, K. Mattle, M. Eibl, H. Weinfurter, and A. Zeilinger, *Nature (London)* **390**, 575 (1997).
- [17] D. Boschi, S. Branca, F. De Martini, L. Hardy, and S. Popescu, *Phys. Rev. Lett.* **80**, 1121 (1998).
- [18] P. W. Shor, in *Proceedings of the 35th Annual Symposium on the Foundations of Computer Science*, Santa Fe, New Mexico, 1994 edited by S. Goldwasser (IEEE, Los Alamitos, CA, 1994), p. 124; L.K. Grover, *Phys. Rev. Lett.* **79**, 325 (1997); D.S. Abrams and S. Lloyd, *ibid.* **79**, 2586 (1997).
- [19] P. G. Kwiat and H. Weinfurter, *Phys. Rev. A* **58**, R2623 (1998).
- [20] M.O. Scully, B.-G. Englert, and C.J. Bednar, *Phys. Rev. Lett.* **83**, 4433 (1999).
- [21] P.D. Townsend, *Nature (London)* **385**, 47 (1997); G. Ribordy, J-D. Gautier, N. Gisin, O. Guinnard, and H. Zbinden, *Electron. Lett.* **34**, 2116 (1998); W.T. Buttler *et al.*, *Phys. Rev. Lett.* **81**, 3283 (1998); *Phys. Rev. A* **57**, 2379 (1998).