

Game theory-based maximum likelihood method for finite-element-model updating of civil engineering structures

Suzana Ereiz^{a,*}, Javier Fernando Jiménez-Alonso^b, Ivan Duvnjak^a, Aleksandar Pavić^c

^a Faculty of Civil Engineering, University of Zagreb, 10 000 Zagreb, Croatia

^b Department of Continuum Mechanics and Structural Analysis, Universidad de Sevilla, 41092 Seville, Spain

^c College of Engineering, Mathematics and Physical Sciences, University of Exeter, EX4 4QF Exeter United Kingdom

ARTICLE INFO

Keywords:

Finite-element-model Updating (FEMU)
Maximum Likelihood Method (MLM)
Bi-objective Optimization
Decision Making
Game Theory
Civil Engineering Structures

ABSTRACT

Finite element modelling is performed to numerically predict the behaviour of civil engineering structures. Due to the different assumptions adopted during the modelling phase, this initial model does not always reflect adequately the actual structural behaviour. In this context, the results of experimental structural dynamic properties can be used to improve initial numerical model via the implementation of the so-called finite element model updating method. After this process, the updated model better reflects the actual structural behaviour. Due to its simplicity, for practical engineering applications, the updating process is usually performed considering the maximum likelihood method. According to this approach, the updating problem may be formulated as the combination of two sub-problems: (i) a bi-objective optimization sub-problem; and (ii) a decision-making sub-problem. The bi-objective function is usually defined in terms of the residuals between the experimental and numerical modal properties. As optimization method, nature-inspired computational algorithms have been usually considered due to their high efficiency to cope with non-linear optimization problems. Despite this extensive use, this method presents two main limitations: (i) the high simulation time required to compute the Pareto optimal front; and (ii) the necessity of solving a subsequent decision making problem (the selection of the best solution among the different elements of the Pareto front). In order to overcome these limitations, in this paper game theory has been adopted as computational tool to improve the performance of the updating process. For this purpose, the updating problem has been re-formulated as a game theory problem considering three different game models: (i) non-cooperative; (ii) cooperative; and (iii) evolutionary. Finally, the performance of proposal has been assessed when it is implemented for the model updating of a laboratory footbridge. As result of this study, game theory has been shown up as efficient tool to improve the performance of the updating process under the maximum likelihood method since it allows a direct estimation of the solution reducing the simulation time without compromising the accuracy of the result.

1. Introduction

In civil engineering, numerical simulation is used to predict the behaviour of structures together with their response to characteristic loads and their combinations. This is most often done via the use of the finite-element (FE) method. However, due to the errors that occur during numerical modelling (such as discretization, parameterization and idealisation), these numerical models may not always reflect adequately the actual behaviour of structure [1]. In order to reduce these errors, the FE model updating (MU) method can be used. According to this method, the value of some physical parameters of the

numerical model is modified in order to reduce the relative difference between the experimental and numerical behaviour of the structure. In order to characterize the experimental behaviour of the structure, results obtained from both on-site static and/or dynamic tests and continuous monitoring are normally considered [2]. After the updating process, the numerical model better simulates the behaviour of the structure. Consequently, the updating process can be used to improve the performance of numerical models when they are employed to simulate the behaviour of structures for different civil engineering applications, such as: (i) the accurate assessment of the actual behaviour of structure [3–6]; (ii) the establishment of methods for damage detection [7–10]; (iii) the establishment of strategies for structural health

* Corresponding author.

E-mail addresses: suzana.ereiz@grad.unizg.hr (S. Ereiz), jfjimenez@us.es (J. Fernando Jiménez-Alonso), ivan.duvnjak@grad.unizg.hr (I. Duvnjak), A.Pavic@exeter.ac.uk (A. Pavić).

<https://doi.org/10.1016/j.engstruct.2022.115458>

Received 8 July 2022; Received in revised form 3 November 2022; Accepted 7 December 2022

Available online 17 December 2022

0141-0296/© 2022 The Author(s). Published by Elsevier Ltd. This is an open access article under the CC BY license (<http://creativecommons.org/licenses/by/4.0/>).

Nomenclature			
FE	Finite element	$d(j, i)$	space distance of j^{th} design variable to i^{th} objective function
SHM	Structural Health Monitoring	$Mo(j)$	moment of j^{th} design variable to all objective functions/ comprehensive degree of influence of j^{th} design variable to all objective function
FEMU	Finite Element Model Updating	λ	threshold of moment
MSE	Modal Strain Energy	GEP	gene expression programming
(r_t^f)	Frequency residuals	MDO	multidisciplinary design optimization (MDO)
(r_t^m)	Mode shape residuals	u_i	utility function
MAC	Modal Assurance Criterion	\bar{f}_i	reference value of the objective function
t	mode number	f_i^k	value of the objective function in the k^{th} game round
f_t^{num}	t^{th} numerically – obtained natural frequency value	f_i^{k-1}	value of the objective function in the $(k-1)^{\text{th}}$ game round
f_t^{exp}	t^{th} experimentally obtained natural frequency	ξ	convergence criterion
ϕ_t^{num}	numerically obtained normalized mode shape vector	POE	Pareto optimal Equilibrium
ϕ_t^{exp}	experimentally obtained normalized mode shape vector	w_{ii}, w_{ij}	Degree of cooperation
$(\phi_t^{\text{num}})^T$	transpose numerically obtained normalized mode shape vector	SPS	Sandwich Plate System
$(\phi_t^{\text{exp}})^T$	transpose experimentally obtained normalized mode shape vector	E^{steel}	modulus of elasticity of steel of numerical model
θ	physical parameters vector/design parameters vector	ρ^{steel}	material density of steel component of numerical model
$F(\theta)$	Objective function	ν^{steel}	Poisson ratio of steel component of numerical model
$f_1(\theta)$ $f_2(\theta)$	objective functions	E_{poly}	modulus of elasticity of polyurethan component of numerical model
n_r	size of the residual vector	ρ_{poly}	material density of polyurethan component of numerical model
n_f	size of the residuals vector related to the natural frequencies	ν_{poly}	modulus of elasticity of polyurethan component of numerical model
n_m	size of the residuals vector related to the mode shapes	k_{lon}	longitudinal stiffness of numerical model supports
$f_1(\theta), f_2(\theta)$	first and second sub-objective functions for the bi-objective approach	k_{trans}	transversal stiffness of numerical model supports
β	Band angle	PS	population size of Harmony search optimization algorithm
BL	Boundary line	I_{max}	Maximum number of the iterations of Harmony search optimization algorithm
MLM	maximum likelihood method	t_{of}	objective function tolerance of the Harmony search optimization algorithm
GT	Game Theory	$P_{s,\text{new}}$	new population size of the Harmony search optimization algorithm
θ_l	lower bound of the physical parameter's vector/design parameters vector	HMCR	Harmony memory pitch adjustment
θ_u	lower bound of the physical parameter's vector/design parameters vector	PAR	Pitch adjustment rate of the Harmony memory search optimization algorithm
$h_d(\theta)$	equality constraint's non upper limit and non-low limit	$\theta_{\text{initial}}^0$	initial values of the design variables
$g_g(\theta)$	inequality constraint's non upper limit and non-low limit	NCGT	non-cooperative game theory
m	dimension of the objective function/ number of game players	CGT	cooperative game theory
n	size of the physical parameter's vector /design parameters vector	EGT	Evolutionary game theory
S_1, \dots, S_m	strategy space of the game players	θ_{HS}^*	Optimal solution of the bi-objective optimization problem using Harmony search optimization algorithm
dg_1, \dots, dg_m	design goals of the game	t_{NCGT}	simulation time algorithm based on non-cooperative game model required for the bi-objective optimization
i	player	t_{CGT}	simulation time algorithm based on cooperative game model required for the bi-objective optimization
$U(i, a)$	utility of item a for player i	t_{EGT}	simulation time algorithm based on evolutionary game model required for the bi-objective optimization
θ_i^*	vector of the optimal values of design variables	t_{HS}	simulation time Harmony search algorithm required for the bi-objective optimization
V	number of the fragments		
$\Delta\theta_j$	step length		
$\Theta(j, i)$	effect of θ_j on the objective function f_i		
$\Delta(j, i)$	impact index of j^{th} design variable to i^{th} objective function		

monitoring [11–14]; and (iv) the determination of strategies for optimal maintenance of infrastructures [15–17]. Hence, the FEMU process can be considered as an inverse problem which main objective is to estimate the value the most relevant physical parameters which govern the behaviour of civil engineering structure [18].

Thus, the updating problem may be formulated as a parameter estimation problem. Two type of estimators can be considered to cope with this problem: (i) deterministic (point estimators); and (ii) stochastic methods (interval estimators). As a conventional point estimator, the maximum likelihood (ML) method [19] has been widely employed to

obtain the expected value of the considered physical variables. As an internal estimator, Bayesian inference [20] has been used to estimate the probability density function of the updating parameters. The good balance between the required simulation time and the accuracy of the solutions have caused that the ML method is usually considered for the model updating of complex civil engineering structures [20]. According to this method, the updating problem can be transformed into an optimization problem. The objective of this optimization problem is to find the value of the updating parameters (the most relevant physical parameters of the model) which minimizes the relative differences

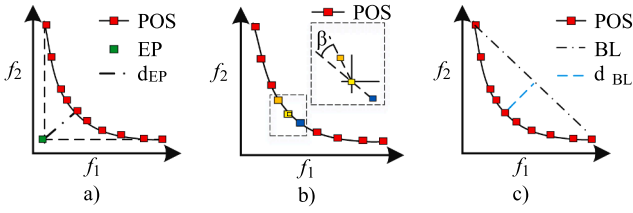

Fig. 1. Different methods to solve the decision-making problem (to find the optimal solution on the Pareto front): a) minimum distance from equilibrium point, b) maximum band angle, c) maximum distance from boundary line (Legend: POS - Pareto optimal solution; EP - Equilibrium Point; d_{EP} - distance from equilibrium point; β - band angle; BL - boundary line; d_{BL} - distance from boundary line).

between the actual behaviour of the structure and the predictions of the numerical model. Among the different methods proposed to select the most relevant updating parameters [21], the sensitivity method [22] has been considered for its good balance between its accuracy and its ease implementation. Hence, the ratio between the modal strain energy (MSE) associated with the considered physical parameters and the overall MSE of the structure is established as selection criterion [23]. The selected parameters must be sensitive to both the uncertainties and the output of the model. Thus, any change in these parameters will affect the correlation between the experimental and numerical response of the structure. Therefore, the optimization algorithm minimizes the relative differences between the experimental and numerical response of the structure via the modification of the value of these physical parameters.

The differences between the experimental and numerical behaviour of the structure may be described in terms of residuals. Two types of residuals are usually considered: (i) frequency residuals (r_t^f); and (ii) mode shape residuals (r_t^m). These residuals can be defined in different way, but they are normally defined as: (i) absolute relative difference (Eq. (1)) for the natural frequencies; and (ii) modal assurance criterion (Eq. (2), (3)) for the mode shapes. Both types of residuals are defined as follows:

$$r_t^f(\theta) = |\Delta f_t| = \left| \frac{f_t^{num} - f_t^{exp}}{f_t^{exp}} \right| \quad (1)$$

$$r_t^m(\theta) = \sqrt{\left(\frac{(1 - \sqrt{\text{MAC}(\phi_t^{exp}, \phi_t^{num})})^2}{\text{MAC}(\phi_t^{exp}, \phi_t^{num})} \right)} \quad (2)$$

$$\text{MAC}(\phi_t^{exp}, \phi_t^{num}) = \frac{|(\phi_t^{num})^t \phi_t^{exp}|^2}{((\phi_t^{num})^T (\phi_t^{num})) \bullet ((\phi_t^{exp})^T (\phi_t^{exp}))} \quad (3)$$

where t is a mode number; f_t^{num} is the t^{th} numerically – obtained natural frequency value; f_t^{exp} is the t^{th} experimentally obtained natural frequency; ϕ_t^{num} is the numerically obtained normalized mode shape vector; ϕ_t^{exp} is the experimentally obtained one; and $()^T$ express the transpose function.

The objective function of the optimization problem may be defined in terms of these residuals. Two different approaches can be considered for this purpose: (i) the single-objective approach (via the weighted sum of the residuals); and (ii) the bi-objective approach (considered a different term for each residual). The bi-objective approach has been considered here since it allows determining the entire set of optimal solutions (the so-called, the Pareto front). According to this approach, the differences between the experimental and numerical behaviour of the structure are characterized via the squared sum of the mentioned residuals (natural frequencies (r_t^f) and mode shapes (r_t^m)) as Eq. (4) expresses:

$$\min(f_1(\theta) \quad f_2(\theta)) = \left(\sum_{t=1}^{n_f} r_t^f(\theta)^2 \quad \sum_{t=1}^{n_m} r_t^m(\theta)^2 \right) \quad (4)$$

As solution of this bi-objective optimization problem, a set of possible solutions is obtained (the Pareto front). A subsequent decision-making problem must be solved, the selection of the best solution among the different elements of the Pareto front [24]. As criterion to select the best solution, the best balanced element of the Pareto front (considering the balance between the variations of the different residuals) is usually considered [25]. The best balanced solutions is denominated as the “knee” point [26]. Different criteria have been proposed for the definition of the “knee” point. Four of the most usually implemented criteria are: (i) the minimum distance from equilibrium point [27]; (ii) the maximum band angle [28]; (iii) maximum distance from boundary line [29]; and (iv) fuzzy logic approach [30]. In order to illustrate how to determine the “knee” point, Fig. 1 shows some of them.

The main limitation for the implementation of the FEMU via a bi-objective optimization problem is the high simulation time required to compute the Pareto front. For this reason, a wide research work has been performed in order to solve the bi-objective optimization problem without computing the mentioned front. Several methods have been proposed to this end. All these methods may be classified in two groups [27]: (i) methods based in the transformation of the bi-objective problem into a weighted sum single-objective problem; and (ii) other type of methods. Among the first group, it can be remarked: (i) the optimally weighted method proposed by Christodoulou et al. [31]; (ii) the adaptive weighted sum method proposed by Kim and Weck [32]; and (iii) the direct estimation method proposed by Ponsi et al. [25]. Alternatively, among the second group, it can be highlighted: (i) the min–max method [33]; (ii) the ideal point method [34]; (iii) the weight square method [35]; (iv) the virtual objective method [36]; and (v) the interactive programming method [37].

To solve the FEMU problem formulated according to the ML method, different computational algorithms have been proposed [20]. The main limitation, to be overcome for these algorithms, is the nonlinear relationship among the updating parameters and the objective function. Therefore, global optimization algorithms must be employed to cope with this problem. Among global optimization algorithms, nature inspired computational algorithms have been widely used to solve the FEMU of civil engineering structures [38]. Some of the most commonly computational algorithms implemented for model updating applications are: (i) genetic algorithm [39]; (ii) particle swarm optimization [40]; (iii) harmony search (HS) [41]; and (iv) simulated annealing [42]. In order to improve the performance of these algorithms (reducing the simulation time without compromising the accuracy of the solution obtained) different techniques can be used: (i) the parallelization of the problem [19]; (ii) the hybridization of the algorithm (combining local and global computational algorithms) [40]; and (iii) the collaborative combination of different machine learning tools [43].

In order to improve the performance of the updating process of complex civil engineering structures, it is necessary to reduce the required simulation time. Among the different mentioned methods [44–49], this paper focuses on the direct estimation of the solution of the bi-objective problem without computing the Pareto front. For this purpose, game theory (GT), a mathematical technique previously implemented to solve successfully multi-objective optimization problems, has been adapted herein for the updating problem. Therefore, according to this method, the conventional bi-objective optimization problem may be transformed into a GT problem via the definition of the bi-objective function as several utility functions. Using this transformation of the objective function, it is possible to obtain the solution of the bi-objective optimization problem directly without computing the Pareto front. In this manner, the bi-objective optimization problem is divided into two single-objective optimization problems. In order to minimize each single-objective optimization problem, a global optimization algorithm must be used. Among the different computational algorithms, a nature-

inspired computational algorithm, HS algorithm, has been considered in this study due to its good balance among the simulation time required, the accuracy of the solution obtained and its ease implementation.

Thus, the main contribution of this paper is to assess the possibility of implementing the GT to improve the performance (reduction of simulation time without compromising the accuracy of the solution) of FEMU of civil engineering under the ML method. Additionally, the performance of three different game models has been assessed when they are implemented for the FEMU of a benchmark structure. As reference, the updating process of this structure is also performed considering a conventional bi-objective optimization method. As result of this study, the advantage of using GT to cope with the updating problem is highlighted.

The paper is organized as follows. In the second section, a literature review has been presented about the implementation of GT to solve optimization problems. Three different game models (non-cooperative, cooperative and evolutionary) have been included. In the third section, the performance of the proposal has been assessed when it is implemented for the model updating of a laboratory footbridge. Additionally, this updating problem has been solve using a conventional method (bi-objective optimization solved via the Pareto front and subsequent decision-making problem). Later, in section fourth, the results obtained using the three different game models have been compared with the ones obtained by the use of the conventional method. In the fifth section, concluding remarks have been included to finish the paper.

2. GT for multi-objective optimization

In a various field of science (such as politics, economy, biology, social sciences [50]) and engineering applications [51], the latest trends in solving multi-objective optimization problems is the implementation of solution methods based on GT. Generally, GT is a mathematic discipline that deals with decision making in situations of conflict and cooperation between rational individuals. Using this discipline, each nature phenomenon is modelled as a game. Each of these terms, nature phenomenon and game, has some rules, which are or are not allowed. There are also information that may or may not be available, decisions that can be made, and the most important, these decisions have an outcome that depends on the decisions of the remaining players.

According to this, the main elements of the game are: (i) the players; (ii) the player strategies; (iii) the utility; (iv) the available information; and (v) the equilibrium. The optimal solution of the game is the optimal strategy; an action that maximizes the player's utility, considering both that there are other players, and that the ultimate utility of an action is affected not only by the decision of a particular player but also by the decisions of the remaining players.

The basic idea of solving an optimization problem using GT is to transform this problem into a GT problem taking into account the following considerations: (i) each term of the multi-objective function is a player; (ii) the design variables of the objective functions are their strategy; and (iii) the objective function values for different set of design variables are the utilities [45]. To solve the optimization problem, different game models can be used: (i) non-cooperative game theory (NCGT) model; (ii) cooperative game theory (CGT) model; and. (iii) evolutionary game theory (EGT) model.

As the name implies, the NCGT model [52], is a game model in which players do not cooperate, while in the CGT game model [48] there are players who cooperate during the game. In addition to the NCGT and CGT models, which propose a fixed behaviour of players during the game (they cooperate or not) there is also an EGT model. This last game model assumes that players change their behaviour during the game as the game evolves [47] (they decide whether to cooperate or not).

Compared to conventional optimization methods, which obtain solutions by merging multiple objective functions, GT methods obtain solutions by partitioning design variables. Selected design variables, which can show the correlations between each optimization goal and the corresponding design variable, are assigned to each game player. Thus, a

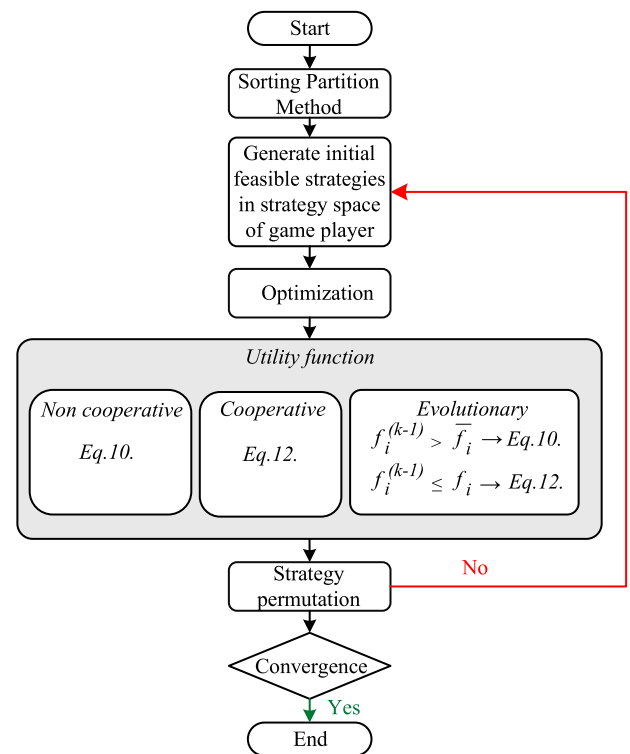

Fig. 2. General flowchart of the GT method to solve the multi-objective optimization problem considering the three mentioned game models: NCGT, CGT, and EGT.

multi-objective optimization problem is transformed into multiple single-objective optimization problems, reducing the complexity of the original problem. Thus, the bi-objective optimization problem, which characterizes the FEMU, can be solved considering the bi-objectives either via the construction of evaluation functions (if a conventional solution method is considered) or via a mapping function (if GT is taken into account) [48].

2.1. General problem

The main aim of a general multi-objective optimization problem is to find the value of the design variables, $\theta = [\theta_1 \ \theta_2 \ \dots \ \theta_n]$, which minimizes the objective function, $F(\theta) = [f_1(\theta) \ \dots \ f_m(\theta)]$, subjected to the following constraints ($\theta_l \leq \theta_i \leq \theta_u$ ($i = 1, \dots, n$); $h_d(\theta) = 0$ ($d = 1, \dots, p$) and $g_e(\theta) = 0$ ($e = 1, \dots, q$)) where θ_i represents each term of the design variable vector; θ_l and θ_u are respectively the lower and upper bounds of the search domain; m is the number of terms of the objective function ($m = 2$ for a bi-objective optimization problem); n is the number of design variables; p is the number of the equality constraints; and q is the number of the inequality constraints.

The general multi-objective optimization problem may be transformed into a GT problem considering the following rules: (i) the m terms of the objective function are transformed into the m game players; (ii) the design variable vector, θ , can be divided into the game strategy S_1, S_2, \dots, S_m ; (iii) the values of objective functions for a particular set of design variables are the corresponding utilities in the game; and (iv) the constraints of the multi-objective optimization problem are the constraints of the game.

Therefore, the multi-objective optimization problem can be redefined as a GT problem, in which the game is represented as $G = \{S_1, \dots, S_m; dg_1, \dots, dg_m\}$ where S_1, \dots, S_m are a strategy set; dg_1, \dots, dg_m are m design goals; and the following rules can be applied to the strategy set: $S_1 \cup \dots \cup S_m = \theta$ and $S_u \cap S_v = \emptyset$ ($u, v = 1, \dots, m; u \neq v$).

To perform the transformation of the multi-objective optimization

problem into the GT problem it is important to perform the division of the design variable vector, θ , into each player strategy space (S_1, \dots, S_m). This can be done using the different methods: (i) fuzzy clustering [53]; (ii) sorting partition method under threshold limit [54]; (iii) spatial game method [55]; and (iv) k-means cluster method [56]. Herein the determination of the game player's strategy space is performed using the sorting partition method (section 2.2) due to its ease implementation and good performance when it has been implemented to solve structural optimization problems [54].

The general flowchart to solve a general multi-objective optimization problem according to the GT method considering the three mentioned game models (NCGT, CGT and EGT) is shown in Fig. 2. The step by step procedure for each mentioned game model is described in detail in: (i) section 2.3 for NCGT model; (ii) section 2.4 for CGT model; and (iii) section 2.5 for EGT model.

2.2. Determination of game player's strategy space

Before starting the definition of the objective function considering the GT method, it is important to perform the division of the selected design variables, θ , into the strategy spaces (S_1, S_2, \dots, S_m) of each game player $i = (1, 2, \dots, m)$. Herein this is performed via the sorting partition method [55] which sort the item based on the utility, $U(i, a)$, of item a for player i according to the following steps:

- Optimize m single objective, and then obtain the optimal solution $f_1(\theta_1^*), f_2(\theta_2^*), \dots, f_m(\theta_m^*)$, where $\theta_i^* = \{\theta_{1i}^*, \theta_{2i}^*, \dots, \theta_{ni}^*\} (i = 1, 2, \dots, m)$
- Every θ_j is divided into V fragments with a step length $\Delta\theta_j$ in its feasible space. The effect of θ_j on the objective f_i is first computed as follows:

$$\Theta(j, i) = \frac{\sum_{v=1}^V |f_i(\theta_{1i}^*, \dots, \theta_{(j-1)i}^*, \theta_j(v), \theta_{(j+1)i}^*, \dots, \theta_{ni}^*)|}{V \bullet \Delta\theta_j} - \frac{f_i(\theta_{1i}^*, \dots, \theta_{(j-1)i}^*, \theta_j(v-1), \theta_{(j+1)i}^*, \dots, \theta_{ni}^*)}{V \bullet \Delta\theta_j} \quad (5)$$

The normalization gives an impact index $\Delta(j, i)$ defined as follows:

$$\Delta(j, i) = \frac{\Theta(j, i)}{\sum_{l=1}^n \Theta(l, i)} \quad (j = 1, 2, \dots, n; i = 1, 2, \dots, m) \quad (6)$$

- $d(j, i)$ is defined as the space distance of θ_j to f_i as follows:

$$d(j, i) = \frac{1}{\sum_{h=1}^m \frac{\Delta(j, i)}{\Delta(j, h)}} \quad (j = 1, 2, \dots, n; i = 1, 2, \dots, m) \quad (7)$$

$Mo(j)$ is defined as the moment of θ_j to all objective functions. It represents the comprehensive degree of influence of θ_j to all objective functions as follows:

$$Mo(j) = \frac{1}{\sum_{h=1}^m \frac{1}{\Delta(j, h)}} \quad (j = 1, 2, \dots, n) \quad (8)$$

The component λ is defined as the moment threshold as follows:

$$\lambda = \frac{\sum_{j=1}^n Mo(j)}{2} \quad (9)$$

The determination of game player's strategy space, sorting of all the design variables to each objective function (which represents each game player) is achieved based on the descending order of $d(j, i)$. If different design variables have the same space distance to the same objective function, the sorting of the design variables is performed according to the impact index following this rule; the higher ranking is assigned to the

objective function that has the greater impact index. The selection of the design variable is performed until the accumulative moment is greater or equal than the moment threshold, λ . The following rules must be taken into account for the assignment of the design variables to each game player's strategy space (terms of the objective function):

- the design variable $\theta_j (j = 1, 2, \dots, n)$ is assigned to the player's strategy space for whom it has the highest rank,
- the design variable $\theta_j (j = 1, 2, \dots, n)$ is assigned to the strategy space based on the highest impact index $\Delta(j, i)$ if it has the same highest ranking among different game players.

The following sub-sections describe in detail the three mentioned game models (NCGT, CGT and EGT). Thus, a literature review has been included for each model. Additionally, the computational steps needed to solve the bi-objective FEMU problem has been enumerated to make easier their practical implementation.

2.3. NCGT model

In the NCGT model, players' benefits are based on their non cooperative behaviour. Therefore, the solution of the game can be found via the application of either the Nash or the Stackelberg equilibrium [57]. The main difference between these two criteria is the players' position: (i) all players share the same position according to the first criterion; and (ii) there is a leader according to the second criterion. Thus, each player makes his decision independently of the other players according to the Nash equilibrium, while the players make their decision based on the leader's decision according to the Stackelberg equilibrium.

Using NCGT models Özyildirim and Alemdar [52] have performed the optimization of the non-renewable resources model considering the Nash equilibrium criterion.

Bezoui et al. [58] proposed a new method for solving bi-objective optimization problems which transforms a multi-objective linear optimization problem into a GT problem that can be solved considering the Nash equilibrium criterion.

Based on a gene expression programming (GEP) and Nash Equilibrium, Xiao et al. [59] have proposed a new approach for multi-objective multidisciplinary design optimization (MDO) problems in NC environments.

Chatterjee and Khas [60] in their study have shown that Nash equilibrium of finite n -person NCGT is equivalent to an optimal solution of the optimization model with zero optimal value.

Spallino and Rizo [53] proposed a NCGT method based on evolutionary strategy in order to solve the multi-objective optimization problem of composite laminated structures. In their method, each game players are an equal body, and eventually found a Nash equilibrium point through negotiation function. These authors showed the efficiency of the proposed method in comparison with the evolutionary strategy and single-objective optimization.

Using three different game model, Holmerg et al. [61] have developed a robust GT method to uncertain loading and exemplified the design of both 2D and 3D structures. The authors showed that the nature of the proposed NC games, between the structure and the external loads, is such that convergence is difficult to obtain – an element may be very important for some loads but completely unnecessary for others. This typically leads to oscillations in the design variable values.

Merging genetic algorithms and Nash strategy, Sim and Kim [62] introduced the Nash genetic algorithm in order to find a Nash equilibrium through a genetic process in which agent populations can evolve into evolutionarily stable strategies (ESS) through the Darwinian selection process.

Regardless of the successful implementation of the NC game model in solving optimization problems, a Nash equilibrium is usually a local optimal profile. If it is not unique and sufficient to assure a global

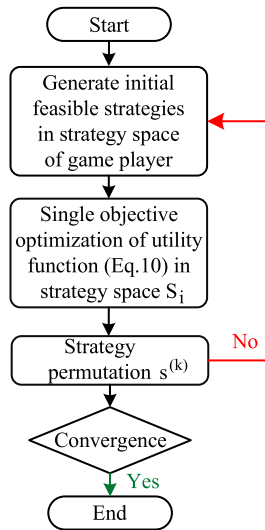

Fig. 3. General flowchart of the GT method to solve the multi-objective optimization problem based on the NCGT model.

optimum solution [63]. In order to ensure a global optimal solution, some more powerful algorithms need to be developed: (i) the use of GT metaheuristic [46]; and (ii) a better determination of the strategy space [64].

The transformation of a FEMU problem into a NCGT problem can be formulated based on the following utility function:

$$u_i = \frac{\bar{f}_i}{f_i} \quad (i = 1, 2, \dots, m) \quad (10)$$

where f_i is the considered term of the objective function, while \bar{f}_i is its reference value (which can eliminate differences in magnitude for each objective function, \bar{f}_i is often set as the initial design value).

Based on the single-objective optimization of each game player's utility function, the best solution (best strategy) is obtained. For the proposed game model, after determination of the strategy space and generation of the initial feasible strategy, the single-objective optimization of the utility function (Eq. (10)) is performed considering the i^{th} game player's strategy space and fixing the supplementary set according to the player's payoff.

After that, the permutation of the defined strategies is performed, and its feasibility is assessed according to all the constraints. If feasibility is dissatisfied, the new initial feasibility is formulated, otherwise, the convergence criterion is checked. If the convergence criterion (9) is satisfied, the game is over, otherwise, the single objective optimization is repeated until all the conditions are met.

$$\sqrt{\sum_{i=1}^m (f_i^k - f_i^{k-1})^2} \leq \xi = 0.001 \quad (11)$$

The complete flowchart to solve the FEMU problem considering the NCGT model is shown in Fig. 3.

2.4. CGT model

In the CGT model, players cooperate and abide by a binding agreement. Therefore, players' benefits are based on their cooperation. In this game model, there are three types of agreements: (i) competitive; (ii) coalition; and (iii) selfless agreement [65]. The main characteristics of the mentioned game model are [54]: (i) self-interest for competitive game; (ii) mutuality for coalition game model, and (iii) collectivistic for selfless agreement.

The CGT model is more frequently used than the NCGT model to cope with different optimization problems. Dhingra and Rao [66]

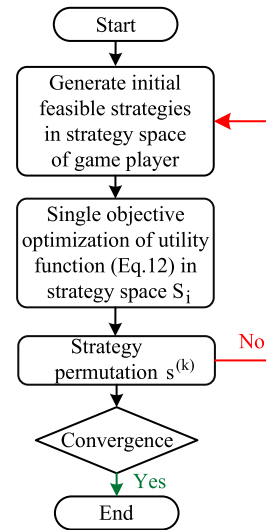

Fig. 4. General flowchart of the GT method to solve the multi-objective optimization problem based on the CGT model.

combined the CGT model and fuzzy set theory to developed a new multi-objective optimization method to deal with the design of high speed mechanisms. Xie et al. [64] proposed a four step GT based method for multi-objective optimization based on the idea that design objectives are used as players and that design variables are decomposed into a set of strategies of all players. By introducing the induced game and transforming the bi-objective optimization problem into the two-player game problem. Monfared et al. [67] ensure the finding the Pareto optimal equilibrium (POE) point more precisely. The authors showed that there is at least one POE point for the class of linear bi-objective optimization problems and that the objective space of multi-objective optimization problem is exactly the payoff space. Rao [44] presented a method for solving the multi-objective optimization problem using the CGT model and concepts for generating the Pareto optimal solution. Vincent [51] studied the role of GT in the process of engineering design and multi-criteria optimization and multiple optimizers. Cheng and Li [68] used a CGT model to find the compromise solution among conflicting objective and combining this game model with genetic algorithms, to propose a new multi-objective optimization algorithm. Annamdas and Rao [49] proposed a propose an algorithm to solve multi-objective optimization problem using a modified CGT model together with the PSO.

The transformation of a FEMU problem into a CGT problem can be formulated based on the following utility function:

$$u_i = w_{ii} \frac{f_i}{\bar{f}_i} + \sum_{j=1, j \neq i}^m w_{ij} \frac{f_j}{\bar{f}_j} \quad (i = 1, 2, \dots, m) \quad (12)$$

where $\sum_{j=1}^m w_{ij} = 1$ are weighting factors.

The value of w_{ij} refers to the degree of cooperation. The greater this value, the lower degree of cooperation. It is worth noting that the w_{ii} and w_{ij} are respectively self-interest and altruistic factors. Their choice in the CGT model should follow two general principles: (i) principles of equilibrium, (the self-interest factor is the sum of all altruistic factors); and (ii) the principle of consistency (all game players select the same altruistic factor during the construction of the profit function).

Based on the single-objective optimization of each player's utility function, the best strategy is obtained. The complete flowchart to solve the FEMU problem considering the CGT model is shown in Fig. 4.

2.5. EGT model

In the EGT model, the players' behaviour evolve as a game evolves

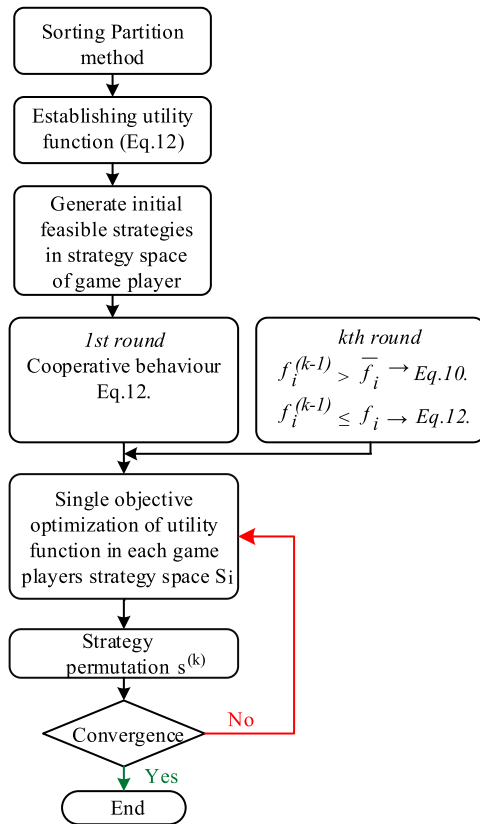

Fig. 5. General flowchart of the GT method to solve the multi-objective optimization problem based on the EGT model.

(the players change their behaviour during the game) [47]. Thus, they cooperate or not according to the outcome (results) of the game. This game model consists of two main components: (i) evolutionary stable strategy [69]; and (ii) replicator dynamic [70].

On the one hand, in evolutionary stable strategy, a population composition is observed that is resistant to the emergence of individuals pursuing a strategy unrelated to the strategy pursued by other individuals in the population (the so-called mutants). For mutants within a population, it is very important that the efficiency they achieve by following their strategy is lower than the efficiency achieved by the rest of the population. On the other hand, replication dynamics is concerned with the question of whether an equilibrium is reached in a population that is out of equilibrium and, if so, which strategies lead to this equilibrium.

Xie et al. [71] proposed a three steps optimization method based on the EGT model. The first step consists of the definition of the players, the design variables and the strategy space via the objective function and fuzzy clustering. The second step is reserved to select each player's behaviour using the evolution rules (the players change their behaviour as a game evolves). In each player's strategy space, each player's utility function is optimized in order to obtain the player's best strategy. In this round, all players' strategies conform the group strategy. Thus, the final equilibrium is obtained based on the convergence criterion via the multi-round game. Meng et al. [54] proposed a novel computationally efficient method to form the players' strategy space, called the sorting partition method under threshold limit. The proposed method is presented via the game profit functions constructed according to both the NCGT and CGT models. The proposed method enables the EGT method to converge potentially faster. In addition, it was shown that the complexity of the problem can be reduced by transforming the original high-dimensional optimization problem into three low-dimensional optimization problems. Jin et al. [45] used an EGT model to transform

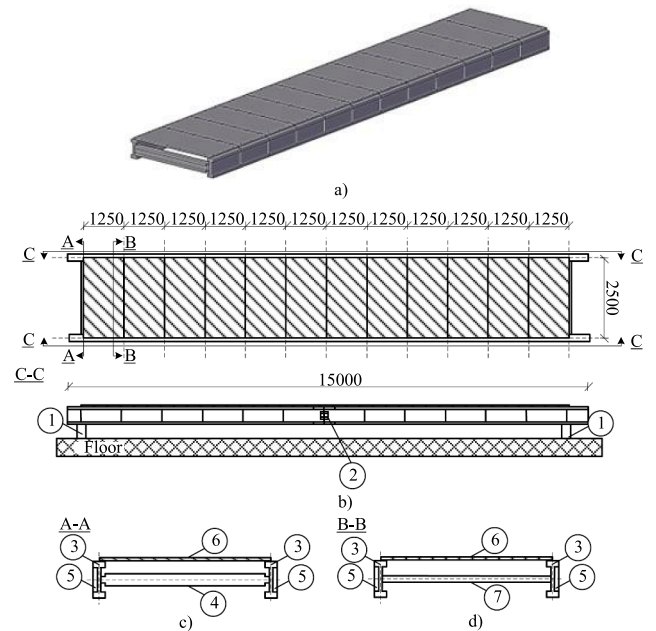

Fig. 6. a) 3D laboratory footbridge model with b) ground plan and characteristic cross-section C—C of the laboratory footbridge c) characteristic cross section A-A, d) characteristics cross section B-B (Legend: 1 - connection with the floor; 2 - connection between UB 457 x 191 x 82; 3 - UB 457 x 191 x 82; 4 - UC 203 x 203 x 60; 5 - transversal stiffeners; 6 - SPS panels; 7 - splice plate. All dimensions are in millimetres).

an optimization problem into a game strategic problem using adaptable dynamic game evolution process. They proposed a large frequency offset precision estimator using the multi-objective optimization theory together with the evolutionary game optimization.

Greiner et al. [72] give a review of the evolutionary algorithms and metaheuristic techniques based on GT. This research study takes into account for NCGT games (Nash equilibrium and Stackelberg game) and CGT games (Pareto optimality). Meng et al. [45] compared the three mentioned game models (NCGT, CGT and EGT). For the optimum design of four bar joist rack structures, m design objectives were considered as m game players, while the design variables were divided into the players' strategy space using fuzzy clustering. Based on the three mentioned GT models, authors concluded that the EGT model is the best model in terms of computational efficiency and accuracy. Both CGT and NCGT models have limitations. Regarding CGT model, its efficiency is limited, and domain decomposition does not significantly help improve efficiency, as the objective functions of all the domains are related. Regarding the NCGT model, the optimal solution in its own domain may be inconsistent with the global optimal solution, because each optimization algorithm aims to obtain the optimal in its own domain without considering the other domains.

Two characteristics of player's behaviour alternates when the EGT model is used to solve the FEMU problem. These characteristics depend on the value of the individual player's utility function and whether the player's benefits is computed according to either a NCGT (Eq. (8)) or a CGT model (Eq. (10)).

In the EGT model (Fig. 5), game starts as either a NCGT model (Fig. 3) or a CGT model (Fig. 4), determining each player's game strategy and establishing the utility function according to the equation (10) and (12). The first round of the game is characterized by the CGT model (the utility function is defined via the equation (12)). In the k^{th} round of game, if the value of the objective function is higher than the value of the initial design, ($f_i^{(k-1)} > \bar{f}_i$), then the player selects the NCGT model (Eq. (10)) while otherwise the player chooses CGT model (Eq. (12)). According to both the selected behaviour (CGT/NCGT

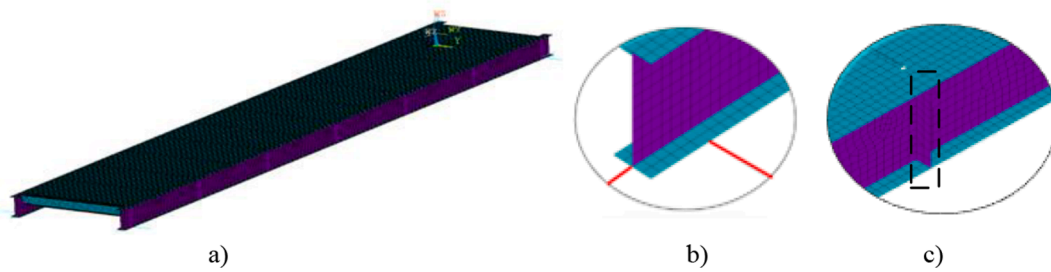

Fig. 7. a) 3D FE model of the laboratory footbridge with b) detail of connections and of c) detail of transverse stiffeners placed at every 1.25 m along the length of the longitudinal beam.

models) and the corresponding utility function, u_i , the single objective optimization in strategy space, S_i , which belongs to the player i is performed. The optimal values obtained are combined and their feasibility is tested. If it is dissatisfied then each player's strategy space is randomly generated, while otherwise the convergence criterion (Eq. (11)) is checked. If it is reached, the game is over, while otherwise, the single-objective optimization is performed again. The complete flowchart to solve the FEMU problem considering the EGT model is shown in Fig. 5.

3. Validation example: FEMU of a laboratory footbridge

The performance of the three mentioned game models (NCGT, CGT and EGT) is assessed when they are implemented for the FEMU of a laboratory footbridge. The footbridge is located at the laboratory of the Vibration Engineering Section of the University of Exeter (UK). It is a single-span footbridge. The length of the span is 15 m (Fig. 6). It consists of two UB $457 \times 191 \times 82$ beams designed to be made from two 7.5 m long beams connected to each other. The bridge span is covered with the Sandwich Plate System (SPS) bolted to the UB $457 \times 191 \times 82$ beams. At the beginning and at the end of the structure there are transverse UC $203 \times 203 \times 60$ beams, while between those two transverse beams at each 1.25 m there are the splice plate with a section of $200 \text{ mm} \times 12 \text{ mm}$. The supports of the structure consist of a column section with stub cantilever which is directly pinned to the floor. For a detailed description of the laboratory footbridge the readers are referred to [73].

This section provides the description of the following topics: (i) the initial numerical model of the laboratory footbridge; (ii) the dynamic test addressed to identify experimentally the modal properties of the structure; (iii) the sensitivity analysis performed to select appropriately

the updating parameters; (iv) the FEMU of the structure considering the two mentioned methods (the GT method considering the three different models and a conventional bi-objective optimization algorithm based on the Pareto front); and (v) the comparison of the results obtained using both methods.

3.1. Initial numerical model

Numerical modelling of laboratory footbridge was performed using the commercial FE package ANSYS [74] and personal computer with processor of 3.59 GHz and a 16 GB RAM memory. FE model (Fig. 7) was developed using: (i) the 3D linear beam element, BEAM 188, for modelling the bolts that configure the connections between the steel structures and SPS panels; (ii) four node shell elements with six degrees of freedom, SHELL 181, for modelling the lateral beams, transversal plates and SPS panels (first order shear deformation theory); (iii) COMBIN14 for modelling support with lateral and longitudinal spring elements, while it is assuming that the vertical displacement was constrained. The developed model was meshed using 31,903 elements.

The initial values of the mechanical properties of the numerical model were assumed as follows. For steel components: (i) the modulus of elasticity was proposed as $E_{\text{steel}} = 2.1 \times 10^5 \text{ MPa}$; (ii) the material density, $\rho_{\text{steel}} = 7850 \text{ kg/m}^3$; and (iii) the Poisson ratio, $\nu_{\text{steel}} = 0.3$. For polyurethane components: (i) the modulus of elasticity was proposed as $E_{\text{poly}} = 750 \text{ MPa}$; (ii) the material density, $\rho_{\text{poly}} = 1100 \text{ kg/m}^3$; and (iii) the Poisson ratio, $\nu_{\text{poly}} = 0.5$. The spring stiffness was determined based on the results of a FE analysis of a column element. Both an equivalent longitudinal, $k_{\text{lon}} = 5.5 \times 10^7 \text{ N/m}$, and transversal, $k_{\text{trans}} = 1.9 \times 10^7 \text{ N/m}$, stiffness were obtained. Based on this FE model, a numerical modal

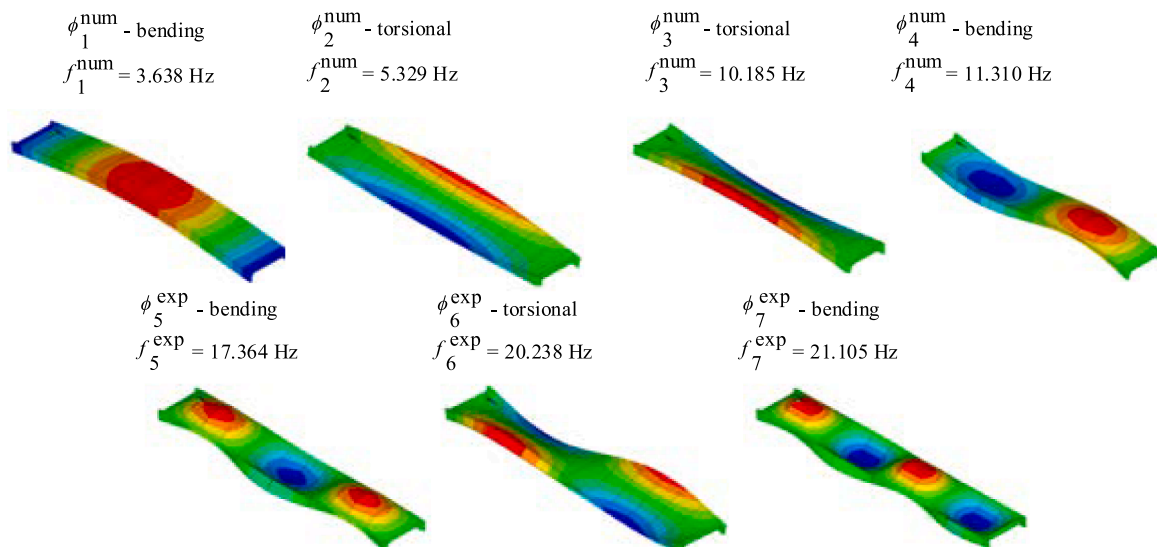

Fig. 8. Numerical natural frequencies (f_t^{num}) and mode shapes (ϕ_t^{num}) obtained from the initial FEM of the laboratory footbridge for $t = 1, \dots, 7$.

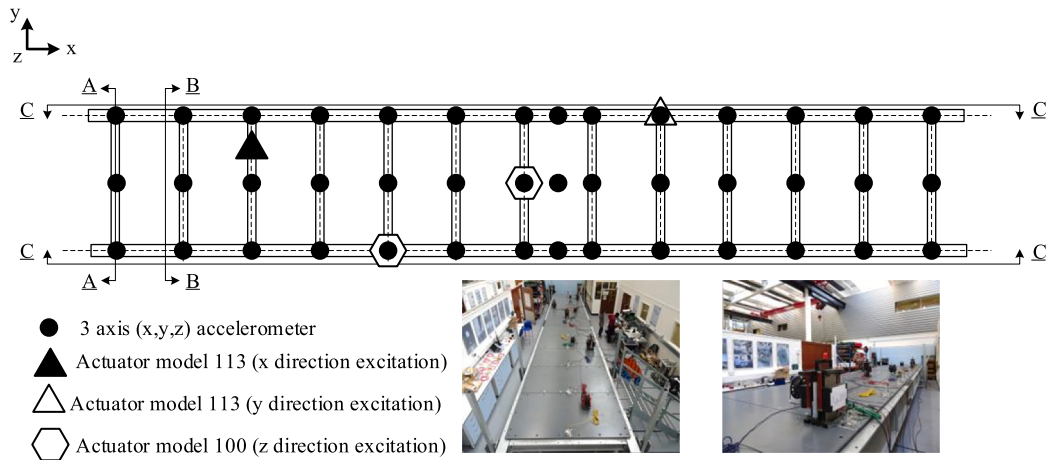

Fig. 9. Layout of the dynamic test performed to identify experimentally the modal properties of the laboratory footbridge [75].

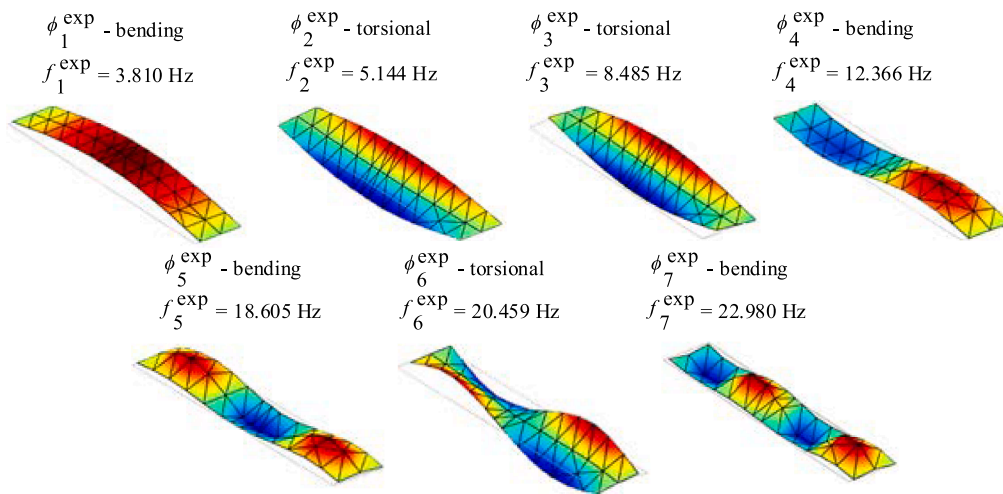

Fig. 10. Experimental modal properties of the laboratory footbridge – experimental natural frequencies (f_t^{exp}) and associated mode shapes (ϕ_t^{exp}) for $t = 1, \dots, 7$ [75].

analysis was performed to obtain the natural frequencies (f_t^{num}) and the mode shapes (ϕ_t^{num}) for each considered mode t . The results of the numerical modal analysis are shown in Fig. 8.

3.2. Experimental identification of modal properties of the laboratory footbridge

The modal properties (natural frequencies and mode shapes) of the laboratory footbridge were experimentally identified via a forced vibration test.

For this purpose, two types of proof mass actuators (two APS Dynamics model 400 with 30 kg of inertial mass and one APS Dynamics model 113 with 13 kg of inertial mass) and several roving accelerometers (Honeywell QA700 and QA750) were used. The actuators were driven simultaneously with uncorrelated random signals generated and recorded using a Data Physics SignalCalc Mobilyzer spectrum analyser. The layout of the experimental dynamic test is shown in Fig. 9.

As result of the identification process, the experimental natural frequencies (f_t^{exp} , $t = 1, \dots, 7$) and associated mode shapes (ϕ_t^{exp}) are shown in Fig. 10. For a detailed description of the experimental investigation together with the forced vibration test, readers are referred to [73].

Table 1

Comparison of the laboratory footbridge behaviour predicted by initial numerical model and its actual behaviour based on the relative differences between the natural frequency, (Δf_t), and the modal assurance criterion $MAC(\phi_t^{exp}, \phi_t^{num})$

Mode shape, t	f_t^{num} [Hz]	f_t^{exp} [Hz]	$ \Delta f_t $ [%]	$MAC(\phi_t^{exp}, \phi_t^{num})$ [/]
1	3.638	3.810	4.51	0.999
2	5.329	5.144	3.60	0.994
3	10.185	8.485	20.03	0.990
4	11.310	12.366	8.54	0.877
5	17.364	18.605	6.67	0.985
6	20.238	20.459	1.08	0.993
7	21.105	22.980	8.16	0.910

3.3. Comparison of the results obtained between initial FE model and the experimental dynamic tests

In order to assess both the performance of the initial numerical model and the accuracy of the predictions of the numerical model, a comparative analysis was performed. Among the different comparison methods [7], a correlation analysis between the experimental and numerical modal properties of the structure was performed. Herein this correlation analysis is performed based on the Eq. (1), for natural frequencies, and the Eq. (3), for the mode shapes. The results of this correlation analysis are shown in Table 1.

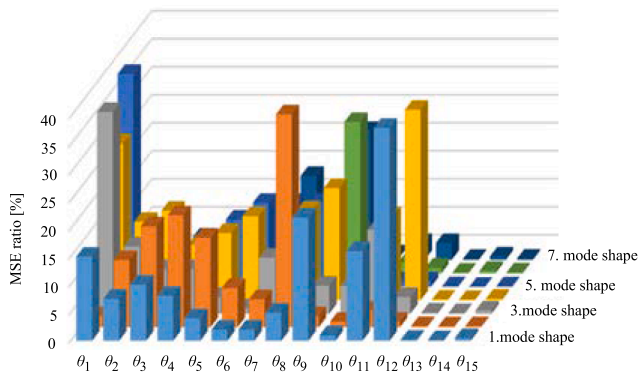

Fig. 11. Sensitivity analysis performed on the laboratory footbridge considering the initial 15 updating parameters.

Table 2

List of the selected updating parameters of the FE model their description and assigned initial values based on the previous studies [79].

Parameter	Description	Initial value
θ_{1-6}	Young modulus of elasticity of steel (longitudinal beam)	$2.1 \cdot 10^5$ [MPa]
θ_7	Young modulus of polyurethane of SPS panels	750 [MPa]
θ_8	Young modulus of elasticity of steel bolts	$2.1 \cdot 10^5$ [MPa]
θ_9	Equivalent longitudinal stiffness of support	$5.5 \cdot 10^7$ [N/m]
θ_{10}	Equivalent transversal stiffness of support	$1.9 \cdot 10^7$ [N/m]

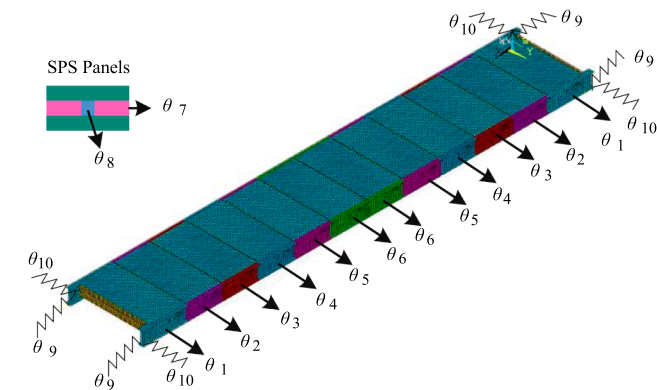

Fig. 12. Selected updating parameters of the FE model of laboratory footbridge.

Table 3

Impact index, space distance, space moment, threshold o moment and ranking of all design variables.

Design variable	$f_1(\theta)$			$f_2(\theta)$			Mo(j)
	$\Delta(j,1)$	$d(j,1)$	ranking	$\Delta(j,2)$	$d(j,2)$	ranking	
θ_1	0.0999826	0.5000757	10	0.1000129	0.4999243	1	0.0499989
θ_2	0.1000049	0.4999847	2	0.0999988	0.5000153	9	0.0500009
θ_3	0.1000049	0.4999847	3	0.0999988	0.5000153	5	0.0500009
θ_4	0.1000049	0.4999847	4	0.0999988	0.5000153	6	0.0500009
θ_5	0.1000049	0.4999847	5	0.0999988	0.5000153	7	0.0500009
θ_6	0.1000049	0.4999847	6	0.0999988	0.5000153	8	0.0500009
θ_7	0.1000011	0.499987	7	0.0999959	0.500013	4	0.0499993
θ_8	0.100006	0.4999817	1	0.0999987	0.5000183	10	0.0500012
θ_9	0.0999934	0.5000146	8	0.0999993	0.4999854	3	0.0499982
θ_{10}	0.0999921	0.5000176	9	0.0999992	0.4999824	2	0.0499978

The results of the comparison analysis suggest that the initial numerical model reproduces poorly the real behaviour of the structure since the MAC ratio of some the first seven mode shapes is lower than 0.9 (a common reference value) and the absolute difference of some natural frequency of these first seven mode shape is greater than 5 % (a common reference value). Therefore, it is necessary to improve the accuracy of the numerical model via a FEMU.

Herein, the FEMU of this laboratory footbridge was performed using the three different GT models (NCGT, CGT and EGT). The performance of the GT models has been analysed in detail. Both the accuracy of the solution obtained and the required simulation time have been compared for this purpose. Additionally, the results obtained have been compared with the ones obtained via a conventional optimization method based on the computation of the Pareto front and the subsequent decision making problem [75].

3.4. Sensitivity analysis and sorting variables in strategy space

Before starting with the FEMU process, it is important to select the most relevant updating parameters. This parameter selection can be performed using different methods [76–78]. Herein a sensitivity analysis has been performed for this purpose (Fig. 11). As selection criterion, the ratio between the modal strain energy associated with physical parameters and the overall modal strain energy (MSE) of the structure has been considered. The selection analysis was performed in two steps. In the first step, a preliminary selection was performed based on engineering judgement. In the second step, this set of parameters was reduced based on the model strain energy ratio.

For the first step, the preliminary set of parameters consists of the same fifteen parameters considered in previous studies [79]. After performing the sensitivity analysis (second step), instead of the selected fifteen parameters (Fig. 11.), only ten of them were included in the FEMU process (Table 2, Fig. 12). The remaining five were excluded due to their reduced effects on the modal properties of this structure.

After performing the selection of the updating parameters, the strategy space of each term of the bi-objective function was defined. For this purpose, the sorting partition method, described in section 2.2. was considered. According to this method, each term of the bi-objective function (the natural frequency residual $f_1(\theta)$, the mode shape residual $f_2(\theta)$) was optimized. The impact index, space distance and space moment were computed. According to the mentioned partition rules, the strategy space of each term of the bi-objective function is defined as follows: $S_1 = (\theta_2, \theta_3, \theta_4, \theta_5, \theta_6, \theta_7, \theta_8, \theta_9)$ and $S_2 = (\theta_1, \theta_9, \theta_{10})$

The detailed information about the exploration of the strategy space is shown in Table 3.

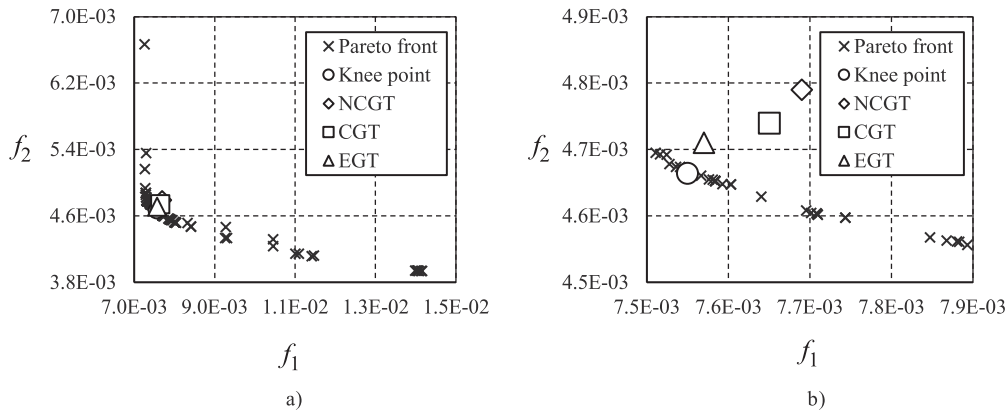

Fig. 13. a) comparison of the “knee” point obtained based on the pareto front (conventional method) with the position of the optimal solutions obtained using the three different game models (NCGT, CGT and EGT) b) detailed view of the position of the different solutions.

Table 4
Results of GT-based ML method for FEMU of laboratory footbridge.

Design variable	Initial Strategy	NCGT		CGT		EGT	
		1st Round	7th Round	1st Round	3rd Round	1st Round	3rd Round
θ_1	1	1.09991	1.10000	1.10000	1.08708	1.10000	1.10000
θ_2	1	1.02509	0.93008	0.92537	0.97482	0.92537	0.96332
θ_3	1	0.92183	1.04725	1.01903	1.02494	1.01903	0.97898
θ_4	1	0.90285	0.91996	0.94027	0.94766	0.94027	1.01693
θ_5	1	0.99868	1.09260	1.08017	1.01102	1.08017	0.96853
θ_6	1	0.98103	0.93418	0.91443	1.05940	0.91443	0.95996
θ_7	1	1.99623	1.64775	1.25622	1.58442	1.25622	1.69470
θ_8	1	2.49993	2.26194	2.50000	2.36780	2.50000	2.30245
θ_9	1	0.75526	0.75000	0.75001	0.75659	0.75001	0.75000
θ_{10}	1	0.79990	0.75295	0.78434	0.77154	0.78434	0.75421
$f_1(\theta)$	2.74E-02	7.97E-03	7.69E-03	8.50E-03	7.65E-03	8.50E-03	7.57E-03
$f_2(\theta)$	1.51E + 01	1.10	4.79E-03	4.94E-03	4.74E-03	4.94E-03	4.71E-03
T [s]			21462		12276		13262

3.5. Solution of the updating problem based on a conventional optimization method

To validate the computational efficiency of the GT algorithms, the FEMU is also performed using a conventional bi-objective optimization method based on the computation of the Pareto front together with a subsequent decision making problem (for the determination of the “knee” point). As optimization algorithm, HS algorithm has been considered herein due to the high performance shown to solve the FEMU problem of civil engineering structures [75]. For a detailed description of the implementation of the HS algorithm to solve the updating problem, readers are referred to [75]. The updating process was performed linking a FE analysis software, Ansys [74], with a mathematical software, Matlab [80].

The following parameters of the HS algorithms were established to perform the optimization process [75]: (i) population size $PS = 100$; (ii) maximum number of iterations $I_{max} = 50$; (iii) objective function tolerance $t_{of} = 1 \cdot 10^{-4}$; (iv) new population size $P_{s,new} = 40$; (v) harmony memory pitch adjustment $HMCR = 0.9$ and (vi) pitch adjusting rate $PAR = 0.3$.

As result of this updating problem, Fig. 13 shows the Pareto front of the two terms of the bi-objective function. Additionally, the “knee” point of this Pareto front (the most balanced solution) has been included in Fig. 13. Therefore, the “knee” point is computed as $\theta_{HS}^* = [1.09516, 1.01464, 1.10000, 1.08621, 0.97957, 0.90000, 1.62927, 2.21290, 0.75000, 0.75977]$.

3.6. Solution of the updating problem based on the GT method

Subsequently, after the determination of each player’s strategy space, the updating problem has been solved using the three GT models (NCGT, CGT and EGT). As it was mentioned, the GT method transforms the bi-objective optimization problem into two single-objective optimization problems. As in the previous section, HS algorithm has been selected as global optimization algorithm to solve these single-objective optimization problems.

The three GT models start from the same initial strategy $\theta_{initial}^0 = [1, 1, 1, 1, 1, 1, 1, 1, 1, 1]$. For each model, the calculation is performed until the convergence criterion is met (Eq. (9)). Herein this convergence criterion, $\xi = 0.001$, was set. For the CGT and EGT models, the degree of the cooperation was established as $w_{11} = w_{22} = w_{12} = w_{21} = 0.5$ according to the rules described in section 2.4. For the sake of simplicity, only the first and last round of each model are shown in Table 4.

As result of the updating process, Fig. 13 also illustrates the solution of the updating problem for the three mentioned game models.

4. Discussion of the results

In order to compare the results obtained according to the two mentioned methods, two comparison criteria have been considered: (i) the accuracy of the solution; and (ii) the simulation time required to compute the solution. On the one hand, Fig. 13 compares graphically the optimum solution provided by the different methods. According to comparison illustrates in Fig. 13, the solution provided by the two method is similar. It can be remarked that the solution provided by the EGT model is better (the nearest to the “knee” point) than the one

Table 5

Correlation between experimental and updated natural frequencies using conventional HS optimization and different game models (NCGT, CGT, EGT).

Vibration mode, t	f_t^{exp} [Hz]	HS		NCGT		CGT		EGT	
		$f_t^{upd,HS}$ [Hz]	$ \Delta f_t^{HS} $ [%]	$f_t^{upd,NCGT}$ [Hz]	$ \Delta f_t^{NCGT} $ [%]	$f_t^{upd,CGT}$ [Hz]	$ \Delta f_t^{CGT} $ [%]	$f_t^{upd,EGT}$ [Hz]	$ \Delta f_t^{EGT} $ [%]
1	3.854	3.875	0.54 %	3.882	0.73 %	3.866	0.31 %	3.883	0.75 %
2	5.489	5.505	0.29 %	5.510	0.38 %	5.500	0.20 %	5.513	0.44 %
3	8.365	8.358	0.08 %	8.336	0.35 %	8.397	0.38 %	8.342	0.27 %
4	11.896	11.946	0.42 %	11.967	0.60 %	11.913	0.14 %	11.973	0.65 %
5	18.662	18.596	0.35 %	18.621	0.22 %	18.565	0.52 %	18.642	0.11 %
6	20.016	20.155	0.69 %	20.191	0.87 %	20.100	0.42 %	20.198	0.91 %
7	22.506	22.357	0.66 %	22.386	0.53 %	22.328	0.79 %	22.418	0.39 %

Table 6

Correlation between experimental and updated mode using conventional HS optimization and different game models (NCGT, CGT, EGT).

Vibration mode, t	MAC ($\phi_t^{exp}, \phi_t^{num}$) [/]			
	HS	NCGT	CGT	EGT
1	0.999	0.999	0.999	0.999
2	0.994	0.994	0.994	0.994
3	0.988	0.988	0.988	0.988
4	0.905	0.880	0.880	0.880
5	0.987	0.987	0.987	0.987
6	0.993	0.993	0.993	0.993
7	0.974	0.961	0.968	0.972

provided by the remaining game models. On the other hand, the simulation time required to perform the updating process, according to the different methods, can be computed as: (i) for the NCGT method; $t_{NCGT} = 21462s$; for the CGT method, $t_{CGT} = 12726s$; for the EGT method, $t_{EGT} = 13262s$; and (iv) for the conventional method, $t_{HS} = 27289s$. It can be also remarked that the CGT model is the quickest method (reduced simulation time). Based on these two comparison criteria, it can be concluded that the GT method can be successfully used to solve the FEMU of civil engineering structures according to the ML method. The GT method allows reducing the simulation time required to perform the FEMU process without compromising the accuracy of the solution. The time reduction is caused by the direct estimation of the “knee” point without the necessity of computing the Pareto front. Additionally, it can be concluded that the EGT model is the best option to perform the FEMU of civil engineering structures since it is the most balanced alternative considering the two comparison criteria.

Finally, the numerical natural frequencies and associated mode shapes of the updated model of the footbridge considering the updating physical parameters provided by the GT method are shown in Table 5 and Table 6 respectively. Additionally, the relative differences and MAC ratio of each mode shape have been computed. The good performance of the solution provided by the GT method it is illustrated in Table 5 and Table 6. Both the relative differences and the MAC ratios provided by the GT method are similar to the ones obtained by the conventional optimization algorithm.

5. Conclusion

Due to its ease implementation, accuracy, and the required simulation time, FEMU for real-world engineering applications is usually performed via the ML method. According to this method, the updating problem can be formulated as a bi-objective optimization problem. However, this method presents two main limitations: (i) a high simulation time to compute the so-called Pareto front (a set with all the possible solutions to the problem); and (ii) the necessity of solving a subsequent decision making problem, the selection of the best solution among the different elements of the Pareto front. In order to cope with these limitations, this paper focuses on the implementation of GT as a

computational tool to improve the performance of the updating process. For this purpose, the efficiency (the accuracy and required simulation time) of three different game models (NCGT, CGT and EGT) have been assessed when they are implemented for the model updating of a benchmark structure (a laboratory footbridge). Additionally, the performance of the proposal has been compared against the results of a conventional method (the optimization of a bi-objective function using the HS algorithm). Three main conclusions can be obtained from this research study:

- 1) The FEMU can be easily formulated as a GT problem considering different game models: (i) NCGT; (ii) CGT; and (iii) EGT.
- 2) Game theory (independently of the considered game model) allows obtaining an accuracy estimation of the so called “knee point” (the best balanced solution of a bi-objective optimization problem) reducing significantly the simulation time in comparison with the conventional methods (bi-objective optimization solved via the use of the Pareto front and subsequent decision-making problem).
- 3) The EGT model shows the best performance among the three considered game models since it allows obtaining both the most accuracy solution and a reduced simulation time.

To sum up, it may be remarked that the EGT model has shown the best performance when it is implemented to solve the FEMU problem of civil engineering structures under the ML method. Despite the high efficiency shown by the GT method to cope with this problem, further studies are needed to improve its accuracy when this mathematical tool is used for the FEMU of complex civil engineering structures. In this case, it can be necessary the use of a decomposition domain method to reduce the possible inconsistency of the solution due to the isolation of each player in its local domain.

Author contribution

Conceptualization – Suzana Ereiz, Javier Fernando Jiménez Alonso. **Data Curation** – Javier Fernando Jiménez Alonso, Aleksandar Pavić. **Format analysis** – Suzana Ereiz, Javier Fernando Jiménez Alonso, Aleksandar Pavić. **Funding Acquisition** – Ivan Duvnjak, Javier Fernando Jiménez Alonso. **Investigation** – Suzana Ereiz, Javier Fernando Jiménez Alonso. **Methodology** – Suzana Ereiz, Javier Fernando Jiménez Alonso. **Project administration** – Ivan Duvnjak, Javier Fernando Jiménez Alonso. **Resources** – Ivan Duvnjak, Javier Fernando Jiménez Alonso, Aleksandar Pavić. **Supervision** – Ivan Duvnjak, Javier Fernando Jiménez Alonso. **Validation** – Suzana Ereiz, Javier Fernando Jiménez Alonso. **Visualization** – Suzana Ereiz. **Writing-original draft** – Suzana Ereiz. **Writing- review and editing** – Ivan Duvnjak, Javier Fernando Jiménez Alonso, Aleksandar Pavić.

Declaration of Competing Interest

The authors declare that they have no known competing financial interests or personal relationships that could have appeared to influence

the work reported in this paper.

Data availability

Data will be made available on request.

Acknowledgements

This research was funded by two research projects: (i) the European project, “Autonomous System for Assessment and Prediction of infrastructure integrity (ASAP)” funded by the European Union through the European Regional Development Fund’s Competitiveness and Cohesion Operational Program, grant number KK.01.1.1.04.0041; and (ii) the Spanish project, “Transport Infrastructures subjected to dynamic loading: assessment techniques for the sustainability, intelligent maintenance and comfort”, grant number PID2021-127627OB-I00, funded by both Ministerio de Ciencia e Innovación, Agencia Estatal de Investigación and FEDER, European Union (10.13039/501100011033).

References

- [1] Simoen E, De Roeck G, Lombaert G. Dealing with uncertainty in model updating for damage assessment: A review. *Mech Syst Signal Process* 2015;56:123–49. <https://doi.org/10.1016/j.ymssp.2014.11.001>.
- [2] Friswell MI, Mottershead JE. *Finite Element Model Updating in Structural Dynamics*. Dordrecht, Netherlands: Springer; 1995.
- [3] Chen H-P, Ni Y-Q, editors. *Structural Health Monitoring of Large Civil Engineering Structures*. Wiley; 2018.
- [4] Moravej H, Jamali S, Chan THT, Nguyen A. Finite element model updating of civil engineering infrastructures: A literature review. *SHMII 2017–8th Int. Conf Struct Heal Monit Intell Infrastructure, Proc* 2017;1139–50.
- [5] Brownjohn JMW, Xia PQ, Hao H, Xia Y. Civil structure condition assessment by FE model updating: Methodology and case studies. *Finite Elem Anal Des* 2001;37:761–75. [https://doi.org/10.1016/S0168-874X\(00\)00071-8](https://doi.org/10.1016/S0168-874X(00)00071-8).
- [6] Bassoli E, Vincenzi L, D’Altri AM, de Miranda S, Forghieri M, Castellazzi G. Ambient vibration-based finite element model updating of an earthquake-damaged masonry tower. *Struct Control Heal Monit* 2018;25:1–15. <https://doi.org/10.1002/stc.2150>.
- [7] Alkayem NF, Cao M, Zhang Y, Bayat M, Su Z. Structural damage detection using finite element model updating with evolutionary algorithms: a survey. *Neural Comput Appl* 2018;30:389–411. <https://doi.org/10.1007/s00521-017-3284-1>.
- [8] Bandara RP, Chan TH, Thambiratnam DP. Structural damage detection method using frequency response functions. *Struct Heal Monit* 2014;13:418–29. <https://doi.org/10.1177/1475921714522847>.
- [9] Saada MM, Arafa MH, Nassef AO. Finite element model updating approach to damage identification in beams using particle swarm optimization. *Eng Optim* 2013;45:677–96. <https://doi.org/10.1080/0305215X.2012.704026>.
- [10] Maia NMM, Almeida RAB, Uargueira APV, Sampaio RPC. Damage detection and quantification using transmissibility. *Mech Syst Signal Process* 2011;25:2475–83. <https://doi.org/10.1016/j.ymssp.2011.04.002>.
- [11] He L, Reynders E, García-Palacios JH, Carlo Marano G, Briseghella B, De Roeck G. Wireless-based identification and model updating of a skewed highway bridge for structural health monitoring. *Appl Sci* 2020;10(7):2347.
- [12] Cabbai A, Gentile C, Saisi A. From continuous vibration monitoring to FEM-based damage assessment: Application on a stone-masonry tower. *Constr Build Mater* 2017;156:252–65. <https://doi.org/10.1016/j.conbuildmat.2017.08.160>.
- [13] Zong Z, Lin X, Niu J. Finite element model validation of bridge based on structural health monitoring—Part I: Response surface-based finite element model updating. *J Traffic Transp Eng (English Ed)* 2015;2:258–78. <https://doi.org/10.1016/j.jtte.2015.06.001>.
- [14] Cui Y, Lu W, Teng J. Updating of structural multi-scale monitoring model based on multi-objective optimisation. *Adv Struct Eng* 2019;22:1073–88. <https://doi.org/10.1177/1369433218805235>.
- [15] Jiménez-Alonso JF, Sáez A. Model updating for the selection of an ancient bridge retrofitting method in Almería. *Spain Struct Eng Int* 2016;26:17–26. <https://doi.org/10.2749/101686615X14355644771333>.
- [16] Chen H-P. Monitoring-Based Reliability Analysis of Aging Concrete Structures by Bayesian Updating. *J Aersp Eng* 2017;30:1–8. [https://doi.org/10.1061/\(asce\)as.1943-5525.0000587](https://doi.org/10.1061/(asce)as.1943-5525.0000587).
- [17] Pachón P, Castro R, García-Macías E, Compan V, Puertas EE. Torroja’s bridge: Tailored experimental setup for SHM of a historical bridge with a reduced number of sensors. *Eng Struct* 2018;162:11–21. <https://doi.org/10.1016/j.engstruct.2018.02.035>.
- [18] National G, Pillars H. *Parameter identification of materials and structures*. Wien New York: Springer; 2005.
- [19] Hofmeister B, Bruns M, Rolfes R. Finite element model updating using deterministic optimisation: A global pattern search approach. *Eng Struct* 2019;195:373–81. <https://doi.org/10.1016/j.engstruct.2019.05.047>.
- [20] Marwala T. *Finite-element-model updating using computational intelligence techniques: Applications to structural dynamics*. 1st editio, Springer-Verlag London, London, England, 2010; . <https://doi.org/10.1007/978-1-84996-323-7>.
- [21] Ahmadian H, Gladwell GML, Ismail F. Parameter selection strategies in finite element model updating. *J Vib Acoust Trans ASME* 1997;119:37–45. <https://doi.org/10.1115/1.2889685>.
- [22] Hamby DM. A Review of Techniques for Parameter Sensitivity. *Environ Monit Assess* 1994;32:135–54. https://deepblue.lib.umich.edu/bitstream/handle/2027.4/2/42691/10661_2004_Article_BF00547132.pdf?sequence=1.
- [23] Fox RL, Kapoor MP. Rates of change of eigenvalues and eigenvectors. *AIAA J* 1968;6:2426–9. <https://doi.org/10.2514/3.5008>.
- [24] Rachmawati L., Srinivasan D. Preference incorporation in multi-objective evolutionary algorithms: A survey. 2006 IEEE Congr. Evol. Comput. CEC 2006 2006; 962–968. <https://doi.org/10.1109/cec.2006.1688414>.
- [25] Ponsi F, Bassoli E, Vincenzi L. A multi-objective optimization approach for FE model updating based on a selection criterion of the preferred Pareto-optimal solution. *Structures* 2021;33:916–34. <https://doi.org/10.1016/j.istruc.2021.04.084>.
- [26] Branke J, Deb K, Dierolf H, Osswald M. Finding knees in multi-objective optimization. *Lect Notes Comput Sci* 2004;722–31. https://doi.org/10.1007/978-3-540-30217-9_73.
- [27] Wang Z, Rangaiah GP. Application and Analysis of Methods for Selecting an Optimal Solution from the Pareto-Optimal Front obtained by Multiobjective Optimization. *Ind Eng Chem Res* 2017;56:560–74. <https://doi.org/10.1021/acs.iecr.6b03453>.
- [28] Jin SS, Cho S, Jung HJ, Lee JJ, Yun CB. A new multi-objective approach to finite element model updating. *J Sound Vib* 2014;333:2323–38. <https://doi.org/10.1016/j.jsv.2014.01.015>.
- [29] Das I. On characterizing the “knee” of the Pareto curve based on normal-boundary intersection. *Struct Optim* 1999;18:107–15. <https://doi.org/10.1007/bf01195985>.
- [30] Furukawa T, Yoshimura S, Mimura Y. A human-like optimization method for constrained parametric design. *Inverse Probl Eng Mech IV* 2003;2003:147–56. <https://doi.org/10.1016/B978-008044268-6/50020-X>.
- [31] Christodoulou K, Ntotsios E, Papadimitriou C, Panetsos P. Structural model updating and prediction variability using Pareto optimal models. *Comput Methods Appl Mech Eng* 2008;198:138–49. <https://doi.org/10.1016/j.cma.2008.04.010>.
- [32] Kim IY, De Weck OL. Adaptive weighted-sum method for bi-objective optimization: Pareto front generation. *Struct Multidiscip Optim* 2005;29:149–58. <https://doi.org/10.1007/s00158-004-0465-1>.
- [33] Kparib DY, Twum SB, Boah DK. A Min-Max Strategy to Aid Decision Making in a Bi-Objective Discrete Optimization Problem Using an Improved Ant Colony Algorithm. *Am J Oper Res* 2019;09:161–74. <https://doi.org/10.4236/ajor.2019.94010>.
- [34] Stoilova S. An integrated multi-criteria and multi-objective optimization approach for establishing the transport plan of intercity trains. *Sustain* 2020;12(2):687.
- [35] Yang X.-S. *Nature-Inspired Optimization Algorithms*. 1st editio, Elsevier, London, England, 2014; . https://doi.org/10.1007/978-981-10-6689-4_8.
- [36] Zarepisheh M, Pardalos PM. An equivalent transformation of multi-objective optimization problems. *Annals of Operations Research* 2017;249:5–15. <https://doi.org/10.1007/s10479-014-1782-4>.
- [37] Marler RT, Arora JS. Function-transformation methods for multi-objective optimization. *Eng Optim* 2005;37:551–70. <https://doi.org/10.1080/03052150500114289>.
- [38] *Nature-Inspired Computation in Engineering*. Springer International Publishing, London, England, 2016.
- [39] Chi J., Liu Y. Multi-objective genetic algorithm based on game theory and its application. *Proc. 2nd Int. Conf. Electron. Mech. Eng. Inf. Technol. EMEIT 2012* 2012; 2341–2344. <https://doi.org/10.2991/emeit.2012.520>.
- [40] Das S., Abraham A., Konar A. Particle swarm optimization and differential evolution algorithms: Technical analysis, applications and hybridization perspectives. 2008; . https://doi.org/10.1007/978-3-540-78297-1_1.
- [41] Geem ZW, Kim JH, Loganathan GV. A new heuristic optimization algorithm: Harmony search. *A New Heuristic Optim. Algorithm Harmon. Search* 2001;76(2):60–8.
- [42] Kirkpatrick S, Gelatt CD, Vecchi MP. Optimization by Simulated Annealing. *Science* 1983;220(4598):671–80.
- [43] Naranjo-Pérez J, Infantes M, Fernando J-A, Sáez A. A collaborative machine learning-optimization algorithm to improve the finite element model updating of civil engineering structures. *Eng Struct* 2020;225. <https://doi.org/10.1016/j.engstruct.2020.111327>.
- [44] Rao SS. Game theory approach for multiobjective structural optimization. *Comput Struct* 1987;25:119–27. [https://doi.org/10.1016/0045-7949\(87\)90223-9](https://doi.org/10.1016/0045-7949(87)90223-9).
- [45] Jin M, Lei X, Du J. Evolutionary game theory in multi-objective optimization problem. *Int J Comput Intell Syst* 2010;3:74–87. <https://doi.org/10.1080/18756891.2010.9727754>.
- [46] Mahjoubi S, Bao Y. Game theory-based metaheuristics for structural design optimization. *Comput Civ Infrastruct Eng* 2021;36:1337–53. <https://doi.org/10.1111/mice.12661>.
- [47] Cheng YR. *Evolutionary Game Theoretic Multi-Objective Optimization Algorithms and Their Applications*. University of Massachusetts Boston; 2017.
- [48] Meng R., Ye Y., Xie N.G. Multi-objective optimization design methods based on game theory. *Proc. World Congr. Intell. Control Autom.* 2010; 2220–2227. <https://doi.org/10.1109/WCICA.2010.5554307>.
- [49] Annamdas KK, Rao SS. Multi-objective optimization of engineering systems using game theory and particle swarm optimization. *Eng Optim* 2009;41:737–52. <https://doi.org/10.1080/03052150902822141>.

- [50] von Neuman J, Morgenstern O. *Theory of Games and Economic Behavior*. Fifth, Princeton University Press, Princeton; 1953. p. ...
- [51] Vincent TL. Game theory as a design tool. *J Mech Des Trans ASME* 1983;105:165–70. <https://doi.org/10.1115/1.3258503>.
- [52] Özyildirim S, Alemdar NM. Learning the optimum as a Nash equilibrium. *J Econ Dyn Control* 2000;24:483–99. [https://doi.org/10.1016/S0165-1889\(99\)00012-3](https://doi.org/10.1016/S0165-1889(99)00012-3).
- [53] Spallino R, Rizzo S. Multi-objective discrete optimization of laminated structures. *Mech Res Commun* 2002;29:17–25. [https://doi.org/10.1016/S0093-6413\(02\)00227-6](https://doi.org/10.1016/S0093-6413(02)00227-6).
- [54] Meng R, Cheong KH, Bao W, Wong KKL, Wang L, Xie N, et al. Multi-objective optimization of an arch dam shape under static loads using an evolutionary game method. *Eng Optim* 2018;50:1061–77. <https://doi.org/10.1080/0305215X.2017.1378876>.
- [55] Wong KKL. Bridging game theory and the knapsack problem: a theoretical formulation. *J Eng Math* 2015;91:177–92. <https://doi.org/10.1007/s10665-014-9742-1>.
- [56] Meng R, Xie N, Wang Lu. Multiobjective game method based on self-adaptive space division of design variables and its application to vehicle suspension. *Math Probl Eng* 2014;2014:1–13.
- [57] Peters H. *Game Theory: A multi-leveled approach*. First, Springer-Verlag Berlin Heidelberg, Maastricht, 2008.
- [58] Bezoui M., Euler R., Moulai M., Boumediene T.H. A game theory approach to solve linear bi-objective programming problems : application to data collection in WSNs. 2017.
- [59] Xiao M, Shao X, Gao L, Luo Z. A new methodology for multi-objective multidisciplinary design optimization problems based on game theory. *Expert Syst Appl* 2015;42:1602–12. <https://doi.org/10.1016/j.eswa.2014.09.047>.
- [60] Chatterjee B. An optimization formulation to compute nash equilibrium in finite games. *Proc Int Conf Methods Model Comput Sci ICM2CS09* 2009. <https://doi.org/10.1109/icm2cs.2009.5397970>.
- [61] Holmberg E, Thore CJ, Klarbring A. Game theory approach to robust topology optimization with uncertain loading. *Struct Multidiscip Optim* 2017;55:1383–97. <https://doi.org/10.1007/s00158-016-1548-5>.
- [62] Sim K-B, Kim J-Y. Solution of multiobjective optimization problems: coevolutionary algorithm based on evolutionary game theory. *Artif Life Robot* 2004;8:174–85. <https://doi.org/10.1007/s10015-004-0308-6>.
- [63] Shamma JS. Special Topic : Games in Control Systems. *Game theory, learning and control systems* 2020;7:1120–2.
- [64] Xie N, Shi N, Bao J, Fang H. *Analysis and Application of Multi-object Decision Design Based on Game Theory*. 6Th World Congr Struct Multidiscip Optim 2005.
- [65] Rui Meng, Ye Ye, Neng-gang Xie. Multi-objective optimization design methods based on game theory, in: 2010 8th World Congr. Intell. Control Autom., IEEE, 2010; .: pp. 2220–2227 <https://doi.org/10.1109/WCICA.2010.5554307>.
- [66] Dhingra AK, Rao SS. A cooperative fuzzy game theoretic approach to multiple objective design optimization. *Eur J Oper Res* 1995;83:547–67. [https://doi.org/10.1016/0377-2217\(93\)E0324-Q](https://doi.org/10.1016/0377-2217(93)E0324-Q).
- [67] Monfared MS, Monabbati SE, Mahdipour Azar M. Bi-objective optimization problems with two decision makers: refining Pareto-optimal front for equilibrium solution. *OR Spectr* 2020;42(2):567–84.
- [68] Cheng F.Y., Li D. Genetic algorithm and Game Theory for multiobjective optimization of seismic structures with/without control, in: *Elev. World Conf. Earthq. Eng., Oxford, England: pERGAMON, Mexico, 1996; .: pp. 1–8*.
- [69] Elsner W, Heinrich T, Schwardt H, Tools II. More Formal Concepts of Game Theory and Evolutionary Game Theory, in: *Microeconomics Complex Econ* 2015:193–226. <https://doi.org/10.1016/b978-0-12-411585-9.00008-7>.
- [70] Elsner W, Heinrich T, Schwardt H. Tools III: An introduction to simulation and Agent-Based Modeling, in: *Microeconomics Complex Econ* 2015:227–49. <https://doi.org/10.1016/b978-0-12-411585-9.00009-9>.
- [71] Xie NG, Meng R, Ye Y, Wang L, Cen YW. Multi-objective design method based on evolution game and its application for suspension. *Struct Multidiscip Optim* 2013; 47:207–20. <https://doi.org/10.1007/s00158-012-0815-3>.
- [72] Greiner D, Periaux J, Emperador JM, Galván B, Winter G. Game Theory Based Evolutionary Algorithms: A Review with Nash Applications in Structural Engineering Optimization Problems. *Arch Comput Methods Eng* 2017;24:703–50. <https://doi.org/10.1007/s11831-016-9187-y>.
- [73] Hudson EJ, Reynolds P. Design and Construction of a Reconfigurable Pedestrian Structure. *Exp Tech* 2017;41:203–14. <https://doi.org/10.1007/s40799-016-0144-3>.
- [74] Ansys | Engineering Simulation Software. no date. <https://www.ansys.com/>.
- [75] Jiménez-Alonso JF, Naranjo-Perez J, Pavic A, Sáez A. Maximum Likelihood Finite-Element Model Updating of Civil Engineering Structures Using Nature-Inspired Computational Algorithms. *Struct Eng Int* 2021;31(3):326–38.
- [76] Jin YF, Yin ZY, Zhou WH, Liu X. Intelligent model selection with updating parameters during staged excavation using optimization method. *Acta Geotech* 2020;15:2473–91. <https://doi.org/10.1007/s11440-020-00936-6>.
- [77] Kim GH, Park YS. An improved updating parameter selection method and finite element model update using multiobjective optimisation technique. *Mech Syst Signal Process* 2004;18:59–78. [https://doi.org/10.1016/S0888-3270\(03\)00042-6](https://doi.org/10.1016/S0888-3270(03)00042-6).
- [78] Wan H-P, Ren W-X. Parameter Selection in Finite-Element-Model Updating by Global Sensitivity Analysis Using Gaussian Process Metamodel. *J Struct Eng* 2015; 141:04014164. [https://doi.org/10.1061/\(asce\)st.1943-541x.0001108](https://doi.org/10.1061/(asce)st.1943-541x.0001108).
- [79] Naranjo-Pérez J, Jiménez-Alonso JF, Pavic A, Sáez A. Finite-element-model updating of civil engineering structures using a hybrid UKF-HS algorithm. *Struct Infrastruct Eng* 2021;17:620–37. <https://doi.org/10.1080/15732479.2020.1760317>.
- [80] Matlab 2022. <https://uk.mathworks.com/>.