

Circuit-level simulation of W-CDMA communication systems applied to the analysis of nonlinear distortion

María J. Madero-Ayora, Javier Reina-Tosina, Ramón Freire-Pérez, Carlos Crespo-Cadenas

Dept. Ingeniería Electrónica. Area de Teoría de la Señal y Comunicaciones

Escuela Superior de Ingenieros, Universidad de Sevilla

Camino de los Descubrimientos, s/n.; 41092 – Seville, Spain

Phone: +34 95 4487335; Fax: +34 95 4487373; E-mail: mjmadero@us.es

Abstract

Different circuit-level approaches to analyze the effects of nonlinear distortion on coded division multiple access (CDMA) wireless communication systems are studied to predict spectral regrowth at the output of a nonlinear device. Measurements of a simple MESFET amplifier tested with a W-CDMA waveform were satisfactorily compared with the simulated results.

Index Terms

Nonlinear distortion, microwave amplifiers, digital communications.

I. INTRODUCTION

The interest on a precise approach to analyze the effects of nonlinear distortion in modern mobile and wireless communication systems is still generating a great effort in the development of simulation techniques [1]. Nonlinear devices generate co-channel and adjacent-channel interference due to intermodulation and spectral regrowth. Therefore, the prediction of nonlinear characteristics such as adjacent channel power rejection (ACPR), constellation distortion and noise power ratio (NPR) in wireless communication systems is an essential task.

This paper is aimed at the simulation of communications signals in presence of a channel with mild nonlinearities where it is necessary to take into account memory effects. A device is said to be memoryless when the output signal at any time sample is only a function of the input at that instant. Unfortunately, many nonlinear devices do not behave like this. Memory effects are defined as variations in the amplitude and phase of distortion components caused by changes in modulation frequency and are attributed to thermal and electrical effects. It is necessary to emphasize the importance of obtaining an accurate model for the nonlinearities of the device apart from using an efficient simulation method in order to achieve the best results.

A number of models have been reported during the last years to account for the effects of nonlinear distortion. Starting with the most simple representation, behavioral modeling allows a quick estimation of nonlinear performance. As an example we can cite Saleh's model [2], which provides AM-AM and AM-PM conversions for a TWT amplifier. However, these conversion characteristics are extracted using a single tone excitation and cannot accurately model memory effects in amplifiers. Another example of a memoryless formulation for the effects of nonlinear distortion on CDMA communication systems is presented in [3]. Considering that in mobile communications the bandwidth of each RF channel is much smaller than the carrier frequency, the RF signal can be represented as a narrowband passband signal using its complex envelope. In [3] a relation between the input and the output complex envelopes is proposed.

Nevertheless, the importance of considering the memory effects on the nonlinearity recommends choosing circuit level approaches, which present more accurate results at the cost of longer simulation times. The predominant technique of Harmonic Balance (HB) provides precise results but has the disadvantage of a high computational cost due to the large number of frequency components to be considered in communication systems driven with digitally modulated signals.

Another technique, the Envelop Transient Analysis [4] decouples RF and baseband spectra gaining in computational efficiency but retaining much of the simulation time.

Other techniques to simulate nonlinear circuits have recently been presented: the Method of Envelop Currents (EC) [5], which is an alternative solution based on the Method of Nonlinear Currents (NC) that exploits the weakly nonlinear characteristics of communication circuits to accomplish a great improvement in simulation speed, and a New Envelope Currents method presented by some of the authors [6], aimed to evaluate nonlinear characteristics of communication circuits which represents a trade-off between precision and computational cost. The most relevant advantage of the EC method is its efficiency, which is specially notable when digitally modulated excitations are used, as is the case of modern mobile and wireless communication systems. This is the reason why this method is going to be used in this communication.

In this paper, we present in Section II-A a discussion about some different approaches for circuit simulation using the EC method. After reviewing the method which is going to be applied, Section II-B presents a characterization procedure of a MESFET device accounting for nonlinearities up to a satisfactory degree of precision as it is showed by comparison with measurements. Afterwards, the method of the EC is applied to that device in Section III in order to evaluate the effects of nonlinearities at the output signals of a MESFET amplifier predicting their spectral regrowth.

II. THEORETICAL DISCUSSION

Overriding the memoryless assumption, circuit level simulation provides a better insight of the nonlinear performance. In this communication, an efficient technique proposed by Borich *et al* [5] for the simulation of weakly nonlinear circuits, the Method of Envelope Currents, is going to be followed. For explanation purposes, let us review its development in a concise way.

A. Circuit simulation

The method of EC is rooted in one of the most popular techniques for nonlinear circuit analysis: the method of Nonlinear Currents (NC), which in turn is based on a Volterra-series description of the incremental node voltages. Components of order n satisfy a nonlinear equation system corresponding to a linear circuit excited by different nonlinear currents for each order which are expressed in terms of voltage components of order $m < n$. The method takes advantage of

the recursive structure of the procedure to obtain these nonlinear excitation currents, although closed-form expressions for the nonlinear currents are rather cumbersome for $n > 3$, limiting thus the practical precision of the algorithm.

The NC method is straightforward to obtain the output response for a single-tone input, when the differential operator $\hat{p} = d/dt$ can be exchanged by the complex frequency $j\omega$, and even with a discrete multitone excitation in terms of nonlinear transfer functions. However, when the driving sources are narrowband communication signals, solving the NC equation system requires a large simulation time. Borich *et al* [5] have proposed the Method of Envelop Currents (EC) as a simple approach to the efficient computation of this equation system in case of narrowband modulated excitations taking the form of the real part of the product of the excitation signal complex envelope and an exponential function at the carrier frequency $\omega_c = 2\pi f_c$.

With an input signal expressed in terms of its complex envelope, any circuit variable $x(t)$ takes the following general form for the n th-order nonlinear current approximation.

$$x_n(t) = \text{Re} \left[\sum_{k=0}^n \tilde{x}_k(t) \exp(jk\omega_c t) \right] \quad (1)$$

where $\tilde{x}_k(t)$ is the complex envelope of the signal around the k th-harmonic of ω_c .

Taking into consideration that the components of $x_n(t)$ which are centered at $-\omega_c, \dots, -n\omega_c$ are the complex conjugates of their positive frequency counterparts, it is usual to omit the real part operator. Two fundamental assumptions are behind the EC: firstly, a quasiperiodic treatment for the complex envelopes around each harmonic of ω_c , i.e. approximate the envelopes as periodic signals and introduce for them a Fourier series representation. Under this assumption, the frequency-domain equivalent for the n th-order NC equation system can be expressed in a simple form using the node-admittance matrix $\mathbf{Y}(\omega)$ of the linear subcircuit as a function of the frequency and the vectors with the Fourier series representation of the node voltage and nonlinear excitation current complex envelopes for the n th-order evaluated around each harmonic $\omega - k\omega_c$, for $k = 0, \dots, n$.

The second assumption taken into account is based on the fact that if the excitation is narrowband, it is possible to take a low-order Taylor series expansion of the admittance matrix in the frequency domain about each harmonic of ω_c without a significative error. In this method it is considered that the first-order approximation is usually sufficient, that is

$$\mathbf{Y}(\omega) \simeq \mathbf{Y}(k\omega_c) + \mathbf{\Omega}_k \mathbf{Y}'(k\omega_c), \quad k = 0, \dots, n \quad (2)$$

$$\mathbf{\Omega}_k = \text{diag}(\omega - k\omega_c)$$

although higher-order expansions may be considered if a better representation of changes in distortion components with the modulation frequency is desired to treat the effects of memory more accurately. When this expansion is substituted in the frequency-domain equivalent for the n th-order NC equation system aforementioned and an inverse Fourier transformation is applied to recover the time-domain expressions of the node voltages, the following expression is obtained

$$\left[\mathbf{Y}(k\omega_c) - j\mathbf{Y}'(k\omega_c)\frac{d}{dt} \right] \tilde{\mathbf{v}}_{nk}(t) = \tilde{\mathbf{i}}_{nk}(t), \quad k = 0, \dots, n, \quad n = 1, \dots, N \quad (3)$$

where $\tilde{\mathbf{v}}_{nk}(t)$ is the vector with the waveforms of the voltage complex envelopes around $k f_c$ for the n th-order nonlinear current solution.

This system of linear differential equations in the complex envelopes can be solved quite efficiently with a Backward-Euler discretization method, in an iterative process that gives M points of the envelope waveforms in an interval $(M - 1)\Delta t$, with Δt being the discretization step. For each iteration, this equation provides the $(m + 1)$ th-value of the node voltage complex envelope waveform, $\tilde{\mathbf{v}}_{nk}[m + 1]$, knowing the previous value $\tilde{\mathbf{v}}_{nk}[m]$ and the $(m + 1)$ th-value of the nonlinear current complex envelope waveform, $\tilde{\mathbf{i}}_{nk}[m + 1]$. The initial condition for the iterative process can be set to zero, $\tilde{\mathbf{v}}_{nk}[0] = 0$. The process must be applied for $k = 0, \dots, n$, and $n = 1, \dots, N$, usually being $N = 3$ the number of nonlinear iterations that can be conveniently managed.

B. Modeling a MESFET device

The method discussed in the previous section has been tested with a simple amplifier at 2 GHz based on a CFB0301 (Celeritek) MESFET. Special care was taken in the following procedure in order to obtain an appropriate model to represent the effects of nonlinearities of the device.

The active device was biased under $V_{DS} = 2$ V and $I_D = 25$ mA and the elements of the small-signal circuit were obtained from S -parameter measurements using standard methods for the extraction of access resistors and the elements of the intrinsic circuit, following an overall optimization with Libra Series IV HP EESOF simulator for parameters R_i and τ .

With regard to the large-signal performance, only the nonlinear current source has been taken into consideration. Its parameters have been fitted to an Angelov model [7] (6 coefficients, with $P_2 = 0$) using the test-bed shown in Fig. 1. Two signals at incommensurate VHF frequencies are

injected into the source and drain ports and the different intermodulation products are measured with a spectrum analyzer. Extraction of the large-signal parameters is accomplished through a double Volterra-series approach [8] comparing measurements of each product with the predicted IMD in terms of nonlinear transfer functions of order $n + m$. The accuracy of the achieved adjustment is depicted in Fig. 2, showing a good agreement.

III. RESULTS

In order to check the accuracy of the methods shown in Section II, we have implemented a MESFET amplifier using a single device. Its performance has been widely characterized at 2 GHz and measurements have been compared with predictions using the large-signal model described previously. Fig. 3 shows the first, second and third harmonics at the output in a wide range of input power levels. Simulations have been accomplished with the EC method using the adjusted Angelov model to obtain the time-varying derivatives of the nonlinear current source. The transducer power gain is depicted in Fig. 4, demonstrating also a good correspondence between measurements and the EC method.

The amplifier has also been tested with a 2 GHz W-CDMA 3GPP QPSK signal at a rate of 3.84 Mcps using raised and root-raised cosine filters. To perform the simulations 256 symbols of a QPSK sequence have been generated taking 8 samples/symbol and using conforming filters with a length equivalent to 24 symbols and a 0.22 roll-off factor. Fig. 5 compares the measured spectrum at the output port with the simulated PSD following the EC method in the case of a raised-cosine filter. Two different input levels are used, the first one low enough for the nonlinearities of the amplifier not to be appreciable and the second one closer to the 1 dB compression point input level, where a notable spectral regrowth causing adjacent-channel interference can be observed. For the sake of comparison, Fig. 6 presents the same information using a root-raised cosine filter, with predictions obtained with the same method. It is clearly noticeable a greater spectral regrowth in the second case because of the conforming filter applied. In both cases simulations agree with measurements satisfactorily.

CONCLUSION

In this paper an efficient circuit-level simulation approach has been applied to the analysis of distortion due to nonlinear channels excited by W-CDMA communication signals. An amplifier at

2 GHz was constructed using a CFB0301 (Celeritek) MESFET with $V_{DS} = 2$ V and $I_D = 25$ mA to test the method. Model parameters for the nonlinear current source of the transistor large-signal equivalent circuit were extracted and used to predict output at fundamental, second and third harmonics. After that, a 2 GHz W-CDMA signal modulated at 3.84 Mcps using raised and root-raised cosine pulses was generated from a vector signal generator and applied to the input of a spectrum analyzer and measurements were compared with results obtained using this technique, showing a good agreement.

ACKNOWLEDGMENTS

This work has been partially funded by the Spanish Board of Scientific and Technical Research (CICYT) under contract TIC2001-0751-C04-04 and by a grant for Coordinated Actions of the Andalusian Government.

REFERENCES

- [1] T. J. Brazil, "Simulating circuits and devices," *IEEE Microwave Magazine* **4**(1), pp. 42–50, 2003.
- [2] A. M. Saleh, "Frequency-independent and frequency-dependent nonlinear models of TWT amplifiers," *IEEE Trans. Commun.* **29**, pp. 1715–1520, Nov. 1981.
- [3] S. W. Chen, W. Pantan, and R. Gilmore, "Effects of nonlinear distortion on CDMA communication systems," *IEEE Trans. on Microwave Theory and Tech.* **44**(12), pp. 2743–2750, Dec. 1996.
- [4] E. Ngoya, and R. Larcheveque, "Envelope Transient Analysis: a new method for the transient and steady state analysis of microwave communication circuits and systems," *IEEE MTT-S 1996 International Microwave Symposium Digest*, pp. 1365–1368, 1996.
- [5] V. Borich, J. East, and G. Haddad, "The method of envelope currents for rapid simulation of weakly nonlinear communications circuits," *IEEE MTT-S 1999 International Microwave Symposium Digest*, pp. 981–984, 1999.
- [6] C. Crespo-Cadenas, and J. Reina-Tosina, "New Envelope Currents Method for the Simulation of Weakly-Nonlinear Communication Circuits," *IEEE Trans. on Microwave Theory and Tech.*, **52**(4), Apr. 2004.
- [7] I. Angelov, H. Zirath, and N. Rorsman, "A New Empirical Nonlinear Model for HEMT and MESFET Devices," *IEEE Trans. on Microwave Theory and Tech.*, **40**(12), Dec. 1992.
- [8] C. Crespo-Cadenas, and J. Reina-Tosina, "Analysis of FET resistive mixers with a double Volterra series approach," *Proc. 2002 European Microwave Conference*, pp. 255–258, Sep. 2002.

LIST OF FIGURES

1 Test-bed configuration for MESFET large-signal characterization. 10

2 Level of IM products at the input of the spectrum analyzer. 11

3 Power levels at the output of the MESFET amplifier for the first, second and third
harmonics. 12

4 Transducer power gain at 2 GHz. 13

5 Output power spectral density at two different input levels using a raised cosine filter. 14

6 Output power spectral density at two different input levels using a root-raised cosine
filter. 15

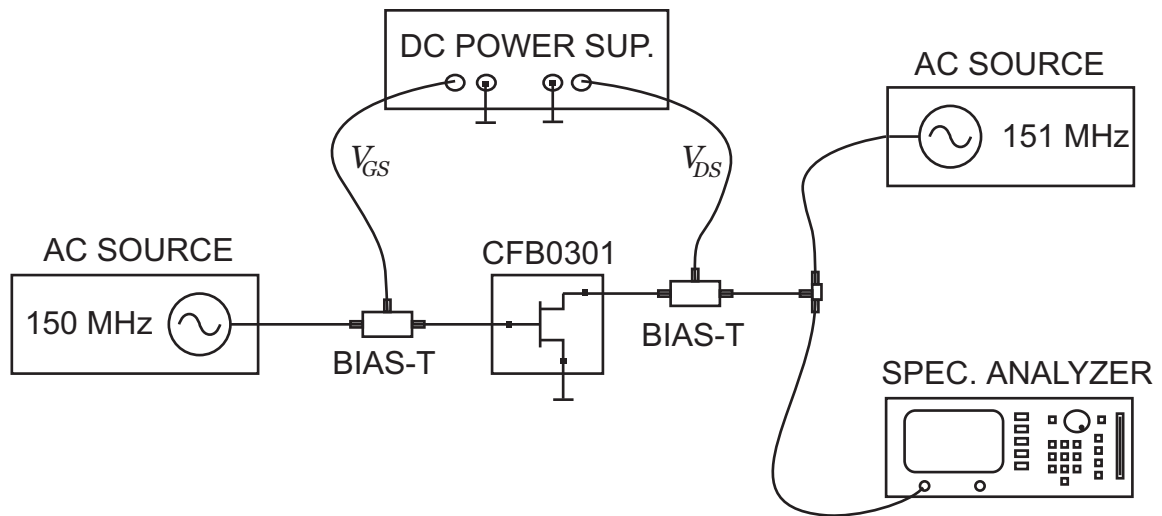

Fig. 1. Test-bed configuration for MESFET large-signal characterization.

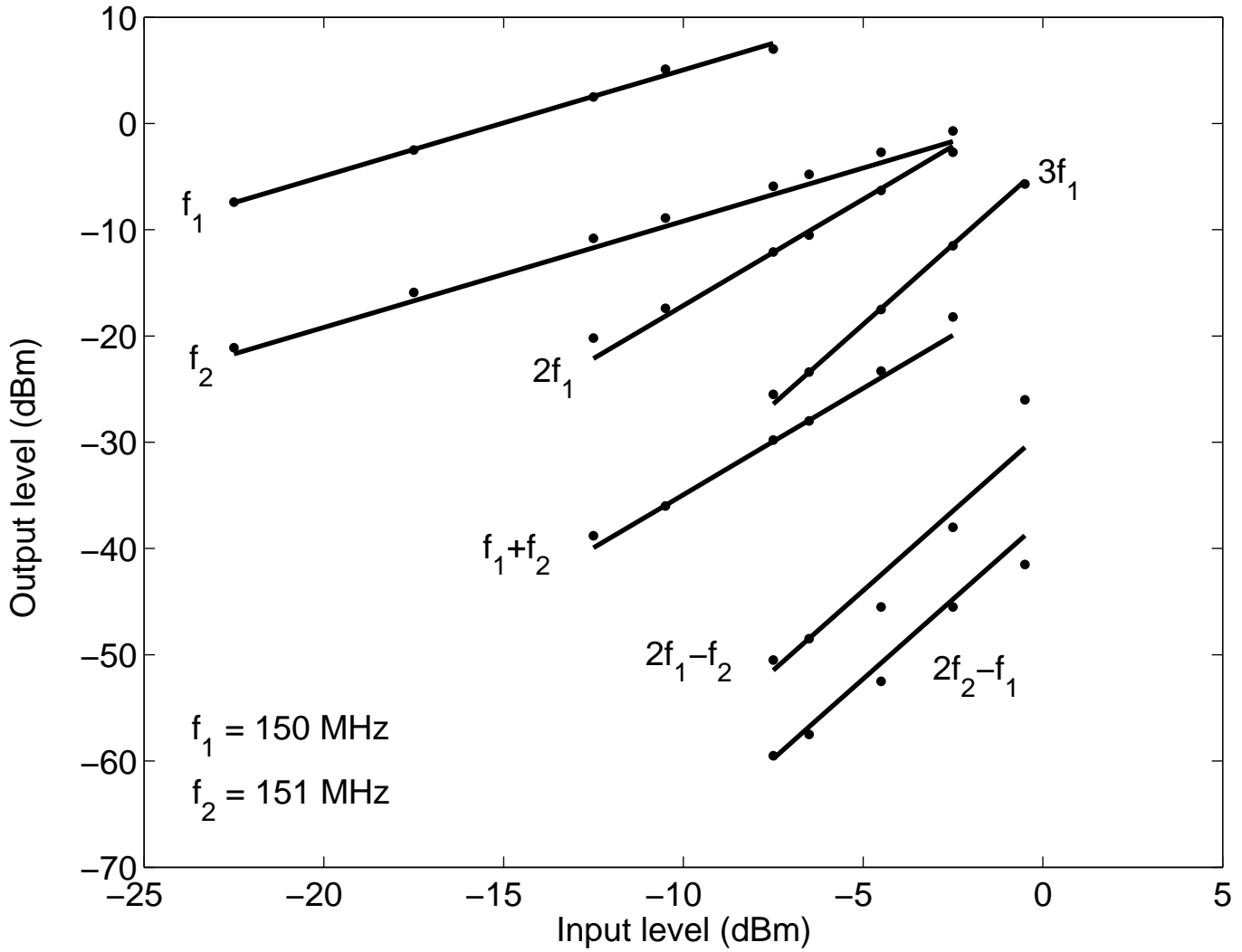

Fig. 2. Level of IM products at the input of the spectrum analyzer: dots, measurements; solid line, predictions with Angelov model.

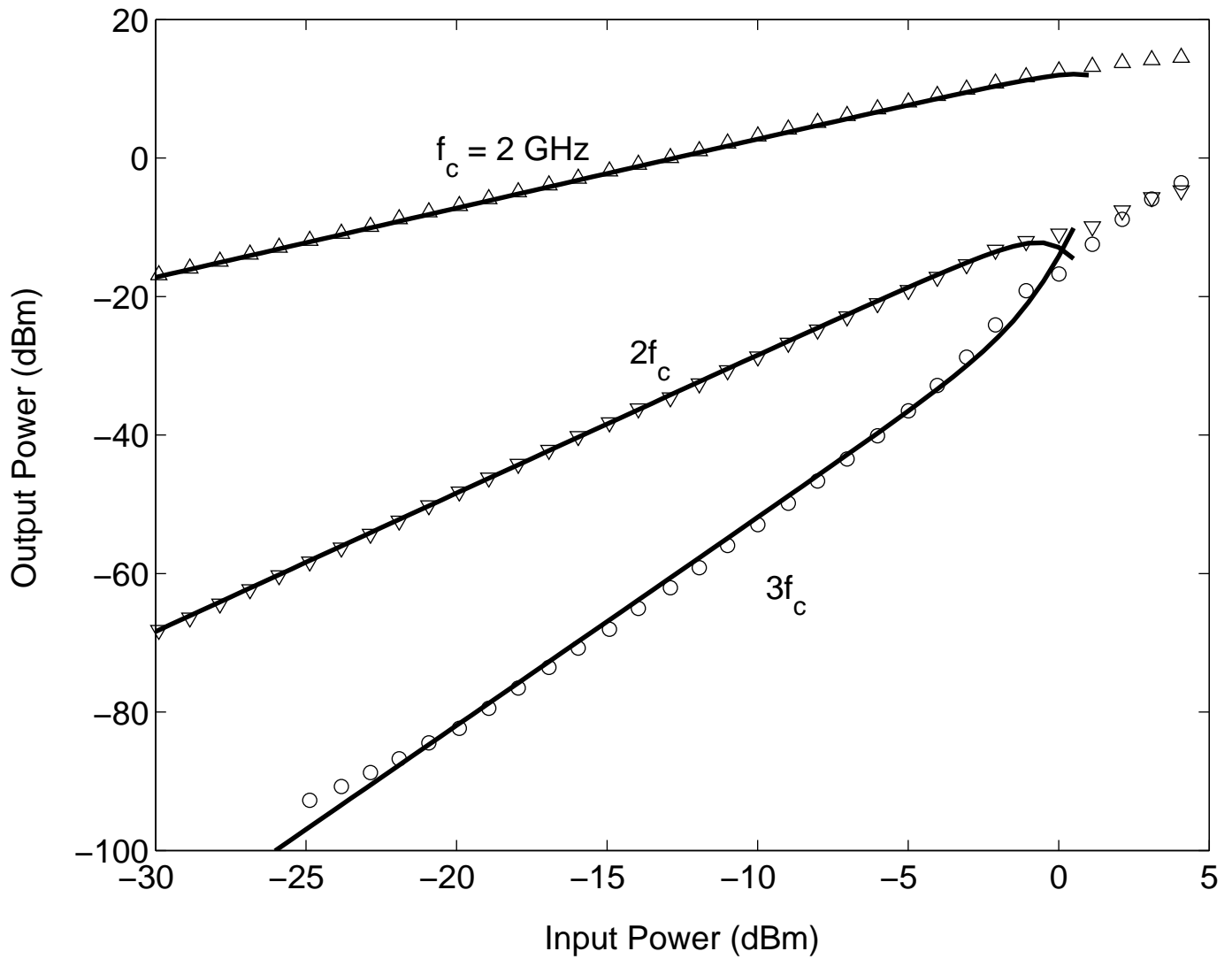

Fig. 3. Power levels at the output of the MESFET amplifier for the first, second and third harmonics. Dots, measurements; solid line, simulation.

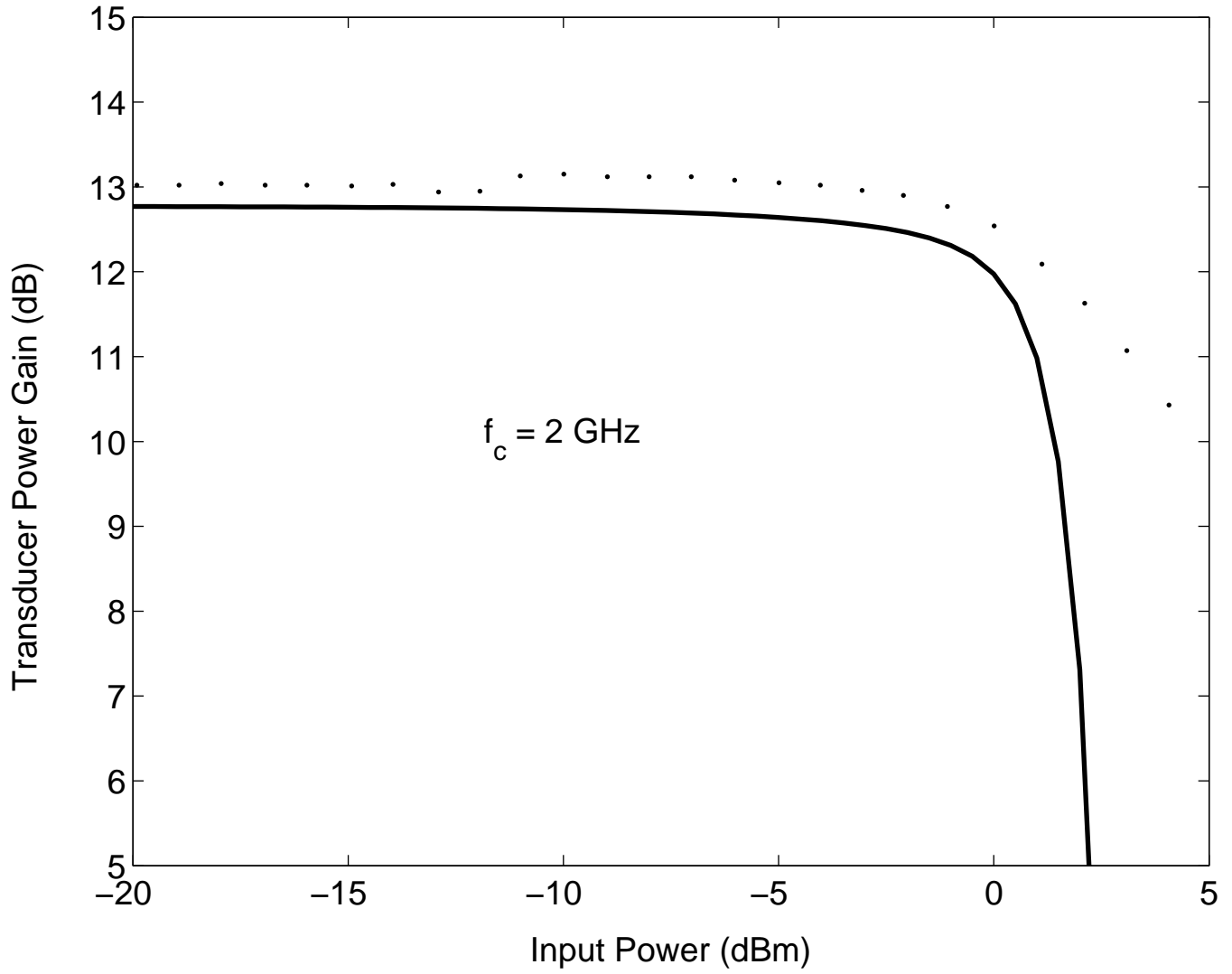

Fig. 4. Transducer power gain at 2 GHz. Dots, measurements; solid line, simulation.

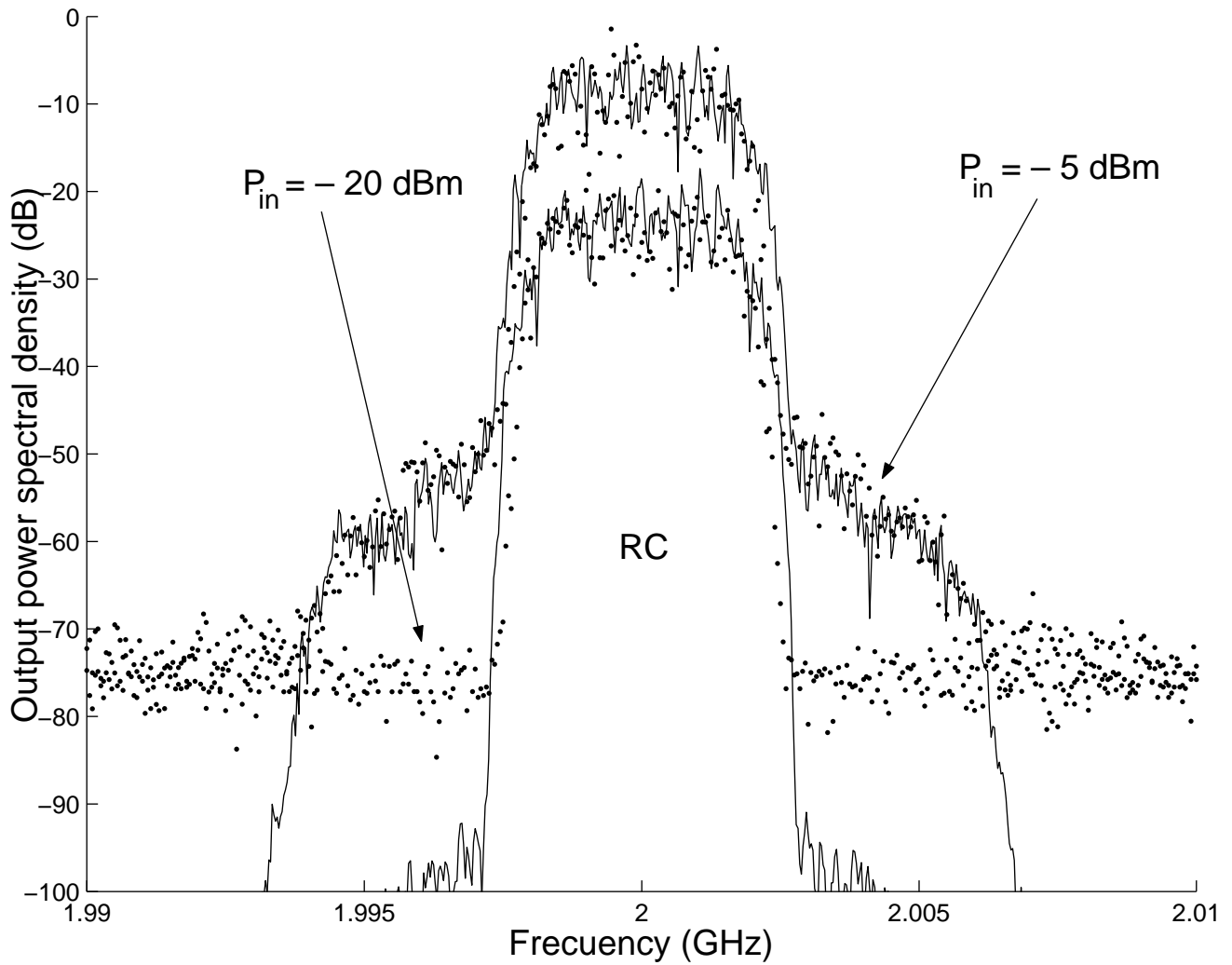

Fig. 5. Output power spectral density at two different input levels using a raised cosine filter. Dots, measurements; solid lines, prediction with EC method.

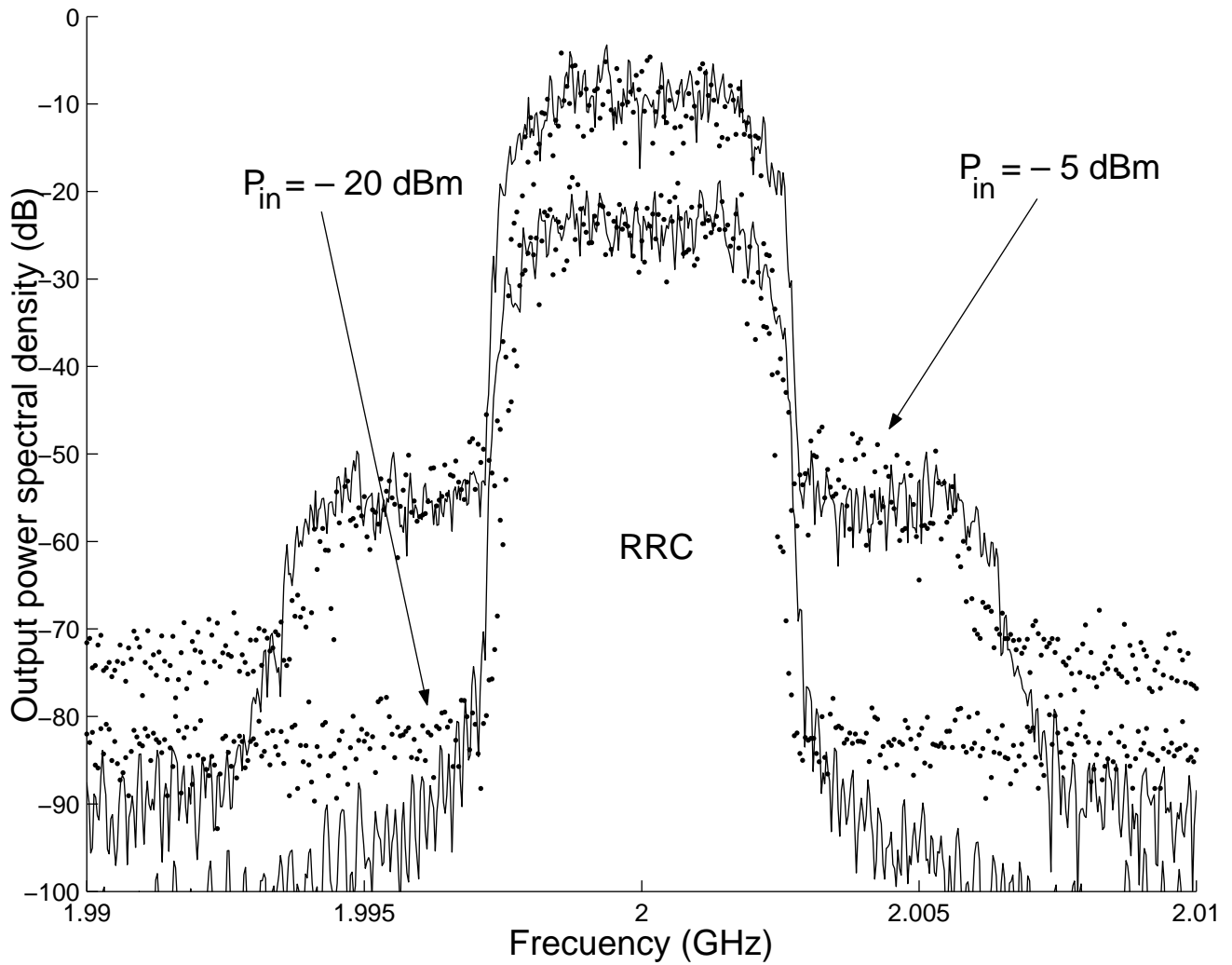

Fig. 6. Output power spectral density at two different input levels using a root-raised cosine filter. Dots, measurements; solid lines, prediction with EC method.