

# Power Electronic Systems for the Grid Integration of Renewable Energy Sources: a Survey

J. M. Carrasco, *Member, IEEE*, L. G. Franquelo, *Fellow, IEEE*, J.T.Bialasiewicz, *Senior Member, IEEE*, E. Galvan, *Member, IEEE*, R. Portillo, M. M. Prats, *Member, IEEE*, J. I. León *Student Member, IEEE*, and N. Moreno.

**Abstract**—The use of distributed energy resources (DER) is increasingly being pursued as a supplement and an alternative to large conventional central power stations. The specification of a power electronics interface is subject to requirements related not only to the renewable energy source itself but also to its effects on power system operation, especially where the intermittent energy source constitutes a significant part of the total system capacity. In this paper, new trends in power electronics for the integration of wind and photovoltaic power generators are presented. A review of appropriate storage systems technology used for the integration of intermittent renewable energy sources is also introduced. Discussions about common and future trends in renewable energy systems based on reliability and maturity of each technology are presented.

**Index Terms**— DFIG, multilevel converter topologies, direct drives, flywheel, hydrogen, SMES, supercapacitors, wind diesel.

## I. INTRODUCTION

THE increasing number of renewable energy sources and distributed generators requires new strategies for the operation and management of the electricity grid in order to maintain or even to improve the power supply reliability and quality. In addition, liberalization of the grids leads to new management structures, in which trading of energy and power is becoming increasingly important. The power electronics technology plays an important role in distributed generation and in integration of renewable energy sources into the electrical grid, and it is widely used and rapidly expanding as these of applications become more integrated with grid-based systems.

During the last few years, power electronics has been undergoing a fast evolution, mainly due to two factors. The first one is the development of fast semiconductor switches, which are capable of switching quickly and handling high powers. The second factor is the introduction of real-time computer controllers that can implement advanced and complex control algorithms. These factors together have led to the development of cost-effective and grid-friendly converters.

J. M. Carrasco, E. Galvan, R. Portillo, M. M. Prats, J. I. Leon, and L. G. Franquelo are with the Department of Electronic Engineering, Seville University, 41092-Seville, SPAIN, e-mail: carrasco@gte.esi.us.es. N. Moreno is with Department of Electrical Engineering, Seville University, 41011-Seville, SPAIN, e-mail: narciso-ma@us.es. J. T.Bialasiewicz is with the Department of Electrical Engineering, University of Colorado at Denver and Health Sciences Center, Denver, CO 80217, USA. e-mail: ian.bialasiewicz@cudenver.edu.

In this paper, new trends in power electronics technology

for the integration of renewable energy sources and energy storage systems are presented. The paper is organized in the following sections. In section II, we describe current technology and future trends in variable speed wind turbines. Wind energy has been demonstrated to be both technically and economically viable. It is expected that current developments in gearless energy transmission with power electronics grid interface will lead to a new generation of quiet, efficient, and economical wind turbines. In section III, we present power-conditioning systems used in grid connected photovoltaic generation plants. The continuously decreasing prices for PV modules lead to the increasing importance of cost reduction of the specific PV converters.

Energy storage in an electricity generation and supply system enables the decoupling of electricity generation from demand. In other words, the electricity that can be produced at times of either low demand low generation cost or from intermittent renewable energy sources is shifted in time for release at times of high demand, high generation cost or when no other generation is available. Appropriate integration of renewable energy sources with storage systems allows for greater market penetration and result in primary energy and emissions savings. In section IV, we present research and development trends in energy storage systems used for the grid integration of intermittent renewable energy sources.

## II. WIND TURBINE TECHNOLOGY

### A. Variable Speed Wind Turbines

Wind energy has matured to a level of development where it is ready to become a generally accepted utility generation technology. Wind turbine technology has undergone a dramatic transformation during the last 15 years, developing from a fringe science in the 1970's to the wind turbine of the 2000's using the latest in power electronics, aerodynamics and mechanical drive train designs [1][2]. In the last five years, the world wind turbine market has been growing at over 30% a year and wind power is playing an increasingly important role in electricity generation, especially in countries such as Germany and Spain. The legislation in both countries favors continuing growth of installed capacity. Wind power is quite different from conventional electricity generation with synchronous generators. Further, there are differences between the different wind turbine designs available on the market. These differences are reflected in the interaction of wind turbines with the electrical power system. An understanding of

this is therefore essential for anyone involved in the integration of wind power into the power system.

Moreover, a new technology has been developed in the wind power market introducing variable speed working conditions depending on the wind speed in order to optimize the energy captured from the wind. The advantages of variable speed turbines are that their annual energy capture is about a 5% greater than fixed speed technology, and that the active and reactive power generated can be easily controlled. There is also less mechanical stress and rapid power fluctuations are scarce, because the rotor acts as a flywheel (storing energy in a kinetic form). In general, no flicker problems occur with variable speed turbines. Variable speed turbines also allow the grid voltage to be controlled, as the reactive power generation can be varied. As disadvantages, variable speed wind turbines need a power converter that increases the component count and make the control more complex. The overall cost of the power electronics is about 7% of the whole wind turbine.

### B. Current Wind Power Technology

Variable speed wind turbines have progressed dramatically in recent years. Variable speed operation can only be achieved by decoupling electrical grid frequency and mechanical rotor frequency. To this end, power electronic converters are used, such as an AC-DC-AC converter combined with advanced control systems.

1) *Variable-Speed Concept Utilizing Doubly Fed Induction Generator (DFIG):* In a variable speed turbine with doubly fed induction generator [3][4], the converter feeds the rotor winding, while the stator winding is connected directly to the grid. This converter, thus decoupling mechanical and electrical frequency and making variable speed operation possible, can vary the electrical rotor frequency. This turbine cannot operate in the full range from zero to the rated speed, but the speed range is quite sufficient. This limited speed range is caused by the fact that a converter considerably smaller than the rated power of the machine is used. In principle one can say that the ratio between the size of the converter and the wind turbine rating is half of the rotor speed span. In addition to the fact that the converter is smaller, the losses are also lower. The control possibilities of the reactive power are similar to the full power converter system. For instance, the Spanish company Gamesa supplies this kind of variable speed wind turbines to the market.

The forced switched power converter scheme is shown in Fig. 1. The converter includes two three-phase AC-DC converters linked by a DC capacitor battery. This scheme allows, on one hand, a vector control of the active and reactive power of the machine, and on the other hand, a decrease by a high percentage of the harmonic content injected into the grid by the power converter.

Vestas and Nordic Windpower supply a variation of this design, the semi-variable speed turbine, in which the rotor resistance of the squirrel cage generator can be varied instantly using fast power electronics. So far, Vestas alone has

succeeded in commercializing this system, under the trade name OptiSlip®. A number of turbines, ranging from 600 kW to 2.75 MW, have now been equipped with this system, which allows transient rotor speed increases of up to 10% of the nominal value. In that case, the variable speed conditions are achieved dissipating the energy within a resistor placed in the rotor as it is shown in Fig. 2. Using that technology, the efficiency of the system decreases when the slip increases and the speed control is limited to a narrow margin. This scheme includes the power converter and the resistors in the rotor. Trigger signals to the power switches are accomplished by optical coupling.

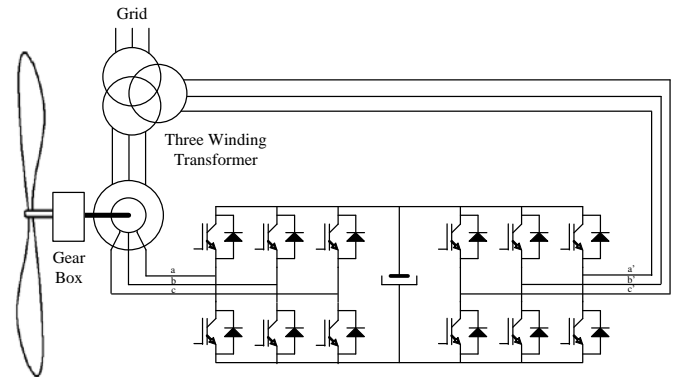

Fig. 1. Single doubly fed induction machine with two fully controlled AC-DC power converters.

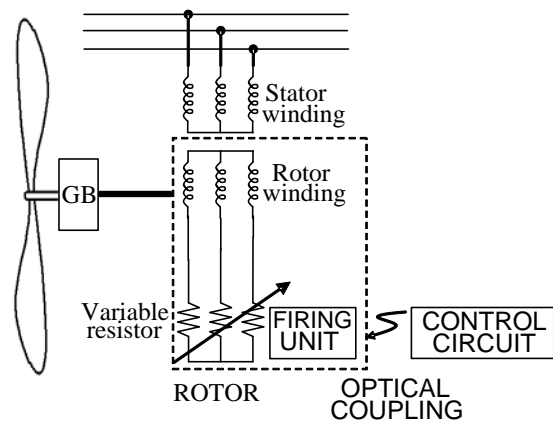

Fig. 2. Single doubly fed induction machine controlled with slip power dissipation in an internal resistor.

2) *Variable-Speed Concept Utilizing Full-Power Converter:* In this concept the generator is completely decoupled from the grid [5]. The energy from the generator is rectified to a DC link, and after this converted to a suitable AC energy for the grid. The majority of these wind turbines are equipped with a multi-pole synchronous generator although it is quite possible (but rather rare) to use an induction generator and a gearbox. There are several benefits of removing the gearbox: reduced losses, lower costs due to the elimination of this expensive component, and increased reliability due to the elimination of rotating mechanical components. Enercon supplies such

technology.

Fig. 3 shows the scheme of a full power converter for a wind turbine. The machine-side three-phase converter works as a driver controlling the torque generator, using a vector control strategy. The grid-side three-phase converter permits wind energy transfer into the grid and enables to control the amount of the active and reactive power delivered to the grid. It also keeps the total harmonic distortion coefficient as low as possible improving the quality of the energy injected into the public grid. The objective of the DC link is to act as energy storage, so that the captured energy from the wind is stored as a charge in the capacitors and may be instantaneously injected into the grid. The control signal is set to maintain a constant reference to the voltage of the DC-link  $V_{dc}$

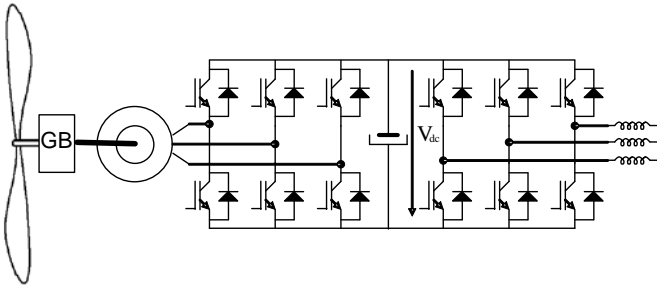

Fig. 3. Double three phase voltage source inverter.

An alternative to the power conditioning system of a wind turbine is to use a synchronous generator instead of an induction one and to replace a three-phase converter (connected to the generator) by a three-phase diode rectifier and a chopper, as shown in Fig. 4. Such choice is based on low cost as compared to an induction generator connected to a voltage source inverter used as a rectifier. When the speed of the synchronous generator alters, the voltage value on the DC-side of the diode rectifier will change. A step-up chopper is used to adapt the rectifier voltage to the DC-link voltage of the inverter. When the inverter system is analyzed, the generator/rectifier system can be modeled as an ideal current source. The step-up chopper used as a rectifier utilizes a high switching frequency so the bandwidth of these components is much higher than the bandwidth of the generator. Controlling the inductance current in the step up converter can control the machine torque and therefore its speed. The Spanish company MADE has marketed that design.

3) *Semiconductor Devices Technology*: Improvements in the performance and reliability of power electronics variable frequency drives for wind turbine applications have been directly related to the availability of power semiconductor devices with better electrical characteristics and lower prices because the device performance determines the size, weight, and cost of the entire power electronics used as interfaces in wind turbines.

The IGBT is now the main component for power electronics and also for wind turbine applications. They are now mature technology turn-on components adapted to very high power (6kV-1.2kA), and they are in competition with GTOs (Gate

turn-off thyristor) for high power applications [6].

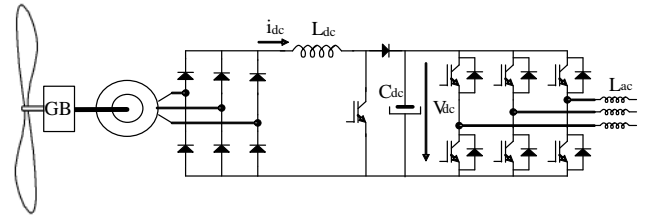

Fig. 4. Step-up converter in the rectifier circuit and full power inverter topology used in wind turbine applications.

Recently, the IGCT (Integrated Gated Control Thyristor) has been developed as a mechanical integration of a GTO plus a delicate hard drive circuit that transforms the GTO into a modern high performance component with a large SOA (Safe Operation Area), lower switching losses, and a short storage time [7]. The comparison between IGCT and IGBT for frequency converters, used especially in wind turbines is explained below:

- IGBTs have higher switching frequency than IGCTs, so they introduce less distortion in the grid.
- IGCTs are made like disk devices. They have to be cooled with a cooling plate by electrical contact on the high voltage side. This is a problem because high electromagnetic emission will occur. Another point of view is the number of allowed load cycles. Heating and cooling the device will always bring mechanical stress to the silicon chip and it can be destroyed. This is a serious problem, especially in wind turbine applications. On the other hand, IGBTs are built like modular devices. The silicon is isolated to the cooling plate and can be connected to ground for low electromagnetic emission even with higher switching frequency. The base plate of this module is made of a special material, which has exactly the same thermal behaviour as silicon, so nearly no thermal stress occurs. This increases the lifetime of the device by 10-fold approximately.
- The main advantage of IGCTs versus IGBTs is that they have a lower on-state voltage drop, which is about 3.0V for a 4500V device. In this case the power dissipation due to a voltage drop for a 1500kW converter will be 2400W per phase. On the other hand, in the case of IGBT the voltage drop is higher than IGCTs. For a 1700V device having a drop of 5V the power dissipation due to the voltage drop for a 1500 kW condition will be 5kW per phase.

In conclusion, with the present semiconductor technology, IGBTs present better characteristics for frequency converters in general and especially for wind turbine applications.

### C. Grid Connection Standards for Wind Farms

1) *Voltage Fault Ride-Through Capability of Wind Turbines*: As wind capacity increases, network operators have to ensure that consumer power quality is not compromised. To enable large-scale application of wind energy without compromising power system stability, the turbines should stay

connected and contribute to the grid in case of a disturbance such as a voltage dip. Wind farms should generate like conventional power plants, supplying active and reactive power for frequency and voltage recovery, immediately after the fault occurred

Thus, several utilities have introduced special grid connection codes for wind farm developers, covering reactive power control, frequency response and fault ride-through, especially in places where wind turbines provide for a significant part of the total power. Examples are Spain, Denmark and part of Northern Germany.

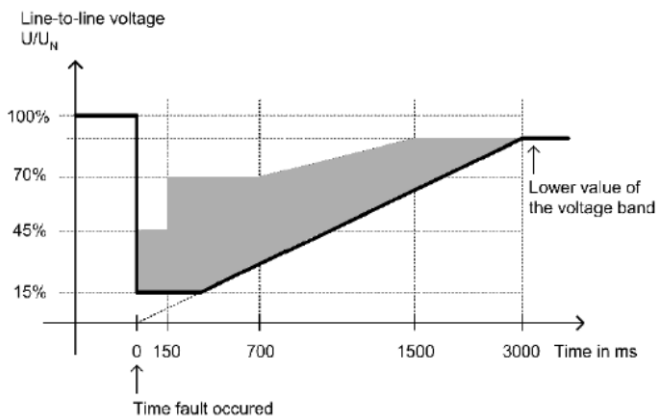

Fig. 5. E.ON Netz requirements for wind farm behavior during faults

The correct interpretation of these codes is crucial for wind farm developers, manufacturers and network operators. They define the operational boundary of a wind turbine connected to the network in terms of frequency range, voltage tolerance, power factor and fault ride-through. Among all these requirements, fault ride-through is regarded as the main challenge to the wind turbine manufacturers. Though the definition of fault ride through varies, the E.ON (German Transmission and Distribution Utility) regulation is likely to set the standard [8]. This stipulates that a wind turbine should remain stable and connected during the fault while voltage at the point of connection drops to 15% of the nominal value (i.e. a drop of 85%) for a period of 150 ms, see Fig. 5.

Only when the grid voltage drops below the curve, the turbine is allowed to disconnect from the grid. When the voltage is in the shaded area the turbine should also supply reactive power to the grid in order to support grid voltage restoration.

2) *Power Quality Requirements for Grid-Connected Wind Turbines:* The grid interaction and grid impact of wind turbines has been focussed on during the past few years. The reason behind this interest is that wind turbines are among utilities considered to be potential sources of bad power quality. Measurements show that the power quality impact of wind turbines has been improved in recent years. Especially variable-speed wind turbines have some advantages concerning flicker. But a new problem arose with variable-speed wind turbines. Modern forced-commutated inverters used in variable-speed wind turbines produce not only harmonics but also inter-harmonics.

IEC initiated the standardization on power quality for wind turbines in 1995 as a part of the wind turbine standardization in TC88, and ultimately 1998 IEC issued a draft IEC-61400-21 standard for "Power Quality Requirements for Grid Connected Wind Turbines" [9]. The methodology of that IEC standard consists of three analyses. The first one is the flicker analysis. IEC-61400-21 specifies a method that uses current and voltage time series measured at the wind turbine terminals to simulate the voltage fluctuations on a fictitious grid with no source of voltage fluctuations other than the wind turbine switching operation. The second one regards switching operations. Voltage and current transients are measured during the switching operations of the wind turbine (start-up at cut wind speed and start-up at rated wind speed). The last one is the harmonic analysis, which is carried out by the FFT algorithm. Rectangular windows of 8 cycles of fundamental frequency width, with no gap and no overlapping between successive windows are applied. Furthermore, the current total harmonic distortion (THD) is calculated up to 50th harmonic order.

Recently, high frequency harmonics and inter-harmonics are treated in the IEC 61000-4-7 and IEC 61000-3-6 [10][11]. The methods for summing harmonics and inter-harmonics in the IEC 61000-3-6 are applicable to wind turbines. In order to obtain a correct magnitude of the frequency components, the use of a well-defined window width, according to the IEC 61000-4-7, Amendment 1 is of a great importance, as it has been reported in [12]. Wind turbines not only produce harmonics, they also produce inter-harmonics, i.e. harmonics, which are not a multiple of 50 Hz. Since the switching frequency of the inverter is not constant but varies, the harmonics will also vary. Consequently, since the switching frequency is arbitrary the harmonics are also arbitrary. Sometimes they are a multiple of 50 Hz and sometimes they are not.

#### D. Trends on Wind Power Technology

1) *Transmission technology for the future-connecting wind generation to the grid:* One of the main trends in wind turbine technology is offshore installation. There are great wind resources at sea for installing wind turbines in many areas where the sea is relatively shallow. Offshore wind turbines may have slightly more favorable energy balance than onshore turbines, depending on local wind conditions. In places where onshore wind turbines are typically placed on flat terrain, offshore wind turbines will generally yield some 50% more energy than a turbine placed on a nearby onshore site. The reason is that there is less friction on the sea surface. On the other hand, the construction and installation of a foundation requires 50% more energy than onshore turbines. It should be remembered, however, that offshore wind turbines have a longer life expectancy than onshore turbines, around 25 to 30 years. The reason is that the low turbulence at sea gives lower fatigue loads on the wind turbine.

Conventional HVAC transmission systems are a simple and cost-efficient solution for the grid connection of wind farms.

Unfortunately for offshore wind parks, the distributed capacitance of undersea cables is much higher than that of overhead power lines. This implies that the maximum feasible length and power transmission capacity of HVAC cables is limited. Grid access technology in the form of high-voltage DC (HVDC) can connect the wind farm parks to the grid and transmit the power securely and efficiently to the load centers. Looking at the overall system economics, HVDC transmission systems are most competitive at transmission distances over 100 km or power levels of between approximately 200 and 900MW. The HVDC transmission offers many advantages over HVAC [13]:

- a) Sending and receiving end frequencies are independent
- b) Transmission distance using DC is not affected by cable charging current.
- c) Offshore installation is isolated from mainland disturbances, and vice versa
- d) Power flow is fully defined and controllable.
- e) Cable power losses are low.
- f) Power transmission capability per cable is higher.

Classical HVDC transmission systems (as shown in Fig. 6a) are based on current source converters with naturally commutated thyristors, so called line-commutated converters (LCC). This name originates from the fact that the applied thyristors need an AC voltage source in order to commutate and thus only can transfer power between two active AC networks. They are therefore less useful in connection with wind farms as the offshore AC grid needs to be powered up prior to a possible start-up. Further disadvantages of LCC based HVDC transmission systems is the lack of the possibility to provide independent control of the active and reactive powers. Furthermore, they produce large amounts of harmonics, which make the use of large filters inevitable.

Voltage Source Inverter (VSC) based HVDC transmission systems are gaining more and more attention, not only for the grid connection of large offshore wind farms. Today, VSC based solutions are marketed by ABB under the name "HVDC Light" [14] and by Siemens under the name "HVDC Plus". Fig. 6b shows the schematic of a VSC based HVDC transmission system. This comparatively new technology (with first commercial installation in 1999) has only become possible by the development of the IGBTs, which can switch off currents. This means that there is no need for an active commutation voltage. Therefore, VSC based HVDC transmission does not require a strong offshore or onshore AC network and can even start up against a dead network (black-start capability). But VSC based systems have several other advantages. The active and reactive power can be controlled independently, which may reduce the need for reactive power compensation and can contribute to stabilization of the AC network at their connection points [15].

2) *High Power Medium-Voltage Converter Topologies:* In order to decrease the cost per MW and to increase the efficiency of wind energy conversion, nominal power of wind turbines has been continuously growing in last years [16].

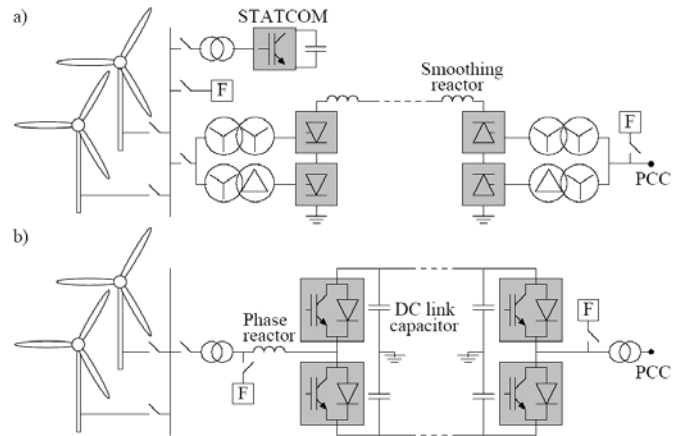

Fig. 6. Two HVDC transmission solutions: a) Classical LCC based system with STATCOM, b) VSC based system.

The different proposed multilevel converter topologies can be classified in the following five categories [17]:

- a) Multilevel configurations with diode clamps.
- b) Multilevel configurations with bi-directional switch interconnection.
- c) Multilevel configurations with flying capacitors.
- d) Multilevel configurations with multiple three-phase inverters.
- e) Multilevel configurations with cascaded single phase H-Bridge inverters

A common feature of the five different topologies of multilevel converters is that, in theory, all the topologies may be constructed to have an arbitrary number of levels, although in practice some topologies are easier to realize than others.

As the ratings of the components increases and the switching and conducting properties improve, the advantages of applying multilevel converters become more and more evident. In recent papers, the reduced content of harmonics in the input and output voltage is highlighted, together with the reduced EMI [18]. Moreover, the multilevel converters have the lowest demands for the input filters or alternatively reduced number of switchings [19]. For the same harmonic performance as a two level converter, the switching frequency of a multilevel converter can be reduced to 25% that results in the reduction of the switching losses [20]. Even though the conducting losses are higher in the multilevel converter, the overall efficiency depends on the ratio between the switching and the conducting losses.

The most commonly reported disadvantage of the multilevel converters with split DC-link is the voltage unbalance between the capacitors that integrate it. Numerous hardware and software solutions are reported: the first one needs additional components that increase the cost of the converter and reduce its reliability; the second one needs enough computational capacity to carry out the modulation signals. Recent papers illustrate that the balance problem can be formulated in terms of the model of the converter and this formulation permits to solve the balancing problem directly modifying the reference voltage with relatively low computational burden [21][22].

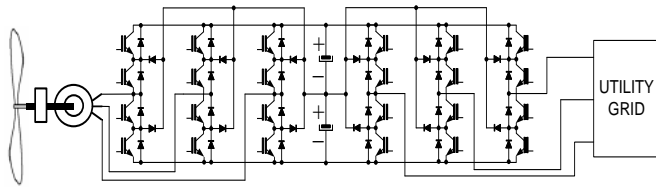

Fig. 7. Multilevel Back-to-Back converter for direct connection of a wind turbine to the utility grid.

Trends on wind turbines market are to increase the nominal power (some Megawatts) and due to that the voltage and current ratings. This makes multilevel converter suitable for modern high power wind turbines applications. The increase of voltage rating allows for connection of the converter of the wind turbine directly to the wind farm distribution network, avoiding the use of a bulky transformer [23], see Fig. 7. The main drawback of some multilevel topologies is the necessity to obtain different DC voltage independent sources needed for the multilevel modulation. The use of low speed permanent magnet generators, that have large number of poles, allows to obtain the DC sources from the multiples wounds of this electrical machine as can be seen in Fig. 8. In this case, the Power Electronics Building Block (PEBB) can be composed of a rectifier, a DC-link and an H-Bridge. Another possibility is to replace the rectifier by an additional H-Bridge.

The continuous reduction of the cost per kW of PEBBs, is making the multilevel cascaded topologies to be the most commonly used by the industrial solutions.

3) *Direct Drive Technology for Wind Turbines:* Direct Drive applications are on increase because the gearbox can be eliminated. As compared to a conventional gearbox-coupled wind turbine generator, a direct drive generator has reduced overall size, lower installation and maintenance cost, a flexible control method and quick response to wind fluctuations and load variation. For small wind turbine, Permanent Magnet Synchronous Machines are more popular because of their higher efficiency, high power density and robust rotor structure as compared to induction and synchronous machines. A number of alternative concepts have been proposed for direct-drive electrical generators for use in grid-connected or stand-alone wind turbines. In [24] the problem to adapt a standard permanent magnet synchronous machine to direct drive application is presented. A complete design of a low-speed, direct drive permanent magnet generator for wind application is depicted in [25] [26].

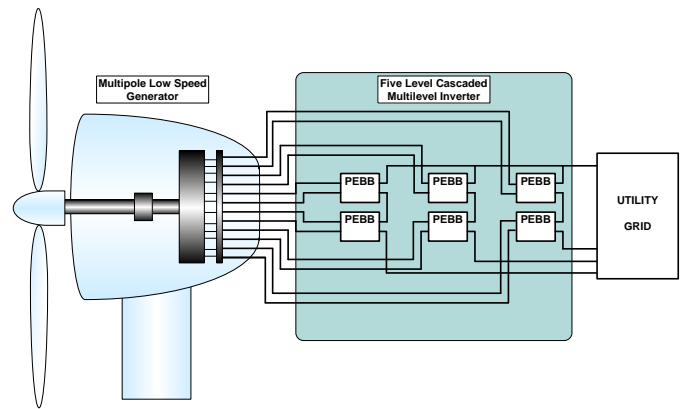

Fig. 8. Five-level cascaded multilevel converter connected to a multi-pole low speed wind turbine generator.

A new trend that is very popular for propulsion systems applications is to use an axial flux machine [27]. This new machines are applied in small-scale wind and water turbine direct drive generators because higher torque density can be obtained in a more simple and easy way.

4) *Future energy storage technologies applied in wind farms:* Energy storage systems can potentially improve the technical and economic attractiveness of wind power, particularly when it exceeds about 10% of total system energy (about 20%–25% of system capacity). The storage system in a wind farm will be used for bulk power storage from wind during time-averaged 15-minute periods of high availability and to absorb or to inject energy over shorter time periods in order to contribute to the grid frequency stabilization.

Several kinds of energy storage technologies are being applied in wind farms. For wind power application, the flow (zinc bromine) battery system offers the lowest cost per energy stored and delivered. The zinc bromine battery is very different in concept and design from more traditional batteries such as the lead acid battery. The battery is based on the reaction between two commonly available chemicals, zinc and bromine. The zinc bromine battery offers 2 to 3 times higher energy density (75 to 85 watt-hours per kilogram) along with size and weight savings over present lead/acid batteries. The power characteristics of the battery can be modified for selected applications. Moreover, zinc bromine battery suffers no loss of performance after repeated cycling. It has a great potential for renewable energy applications [28].

As wind penetration increases, the hydrogen options become most economical. Also, sales of hydrogen as a vehicle fuel are more lucrative than reconverting the hydrogen back into electricity. Industry is developing low-maintenance electrolyzers to produce hydrogen fuel. Because these electrolyzers require a constant minimum load, wind turbines must be integrated with grid or energy systems to provide power in the absence of wind [28].

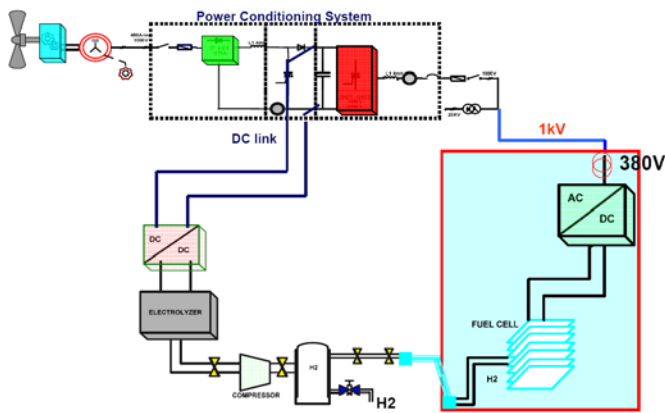

Fig. 9. Variable speed wind turbine with a hydrogen storage system and a fuel cell system that reconverts hydrogen to electrical grid.

Electrical energy could be produced and delivered to the grid from hydrogen by a fuel cell or a hydrogen combustion generator. The fuel cell produces power through a chemical reaction and energy is released from the hydrogen when it reacts with the oxygen in the air. Also, wind electrolysis promises to establish new synergies in energy networks. It will be possible to gradually supply domestic natural gas infrastructures, as reserves diminish, by feeding hydrogen from grid-remote wind farms into natural gas pipelines. Fig. 9 shows a variable speed wind turbine with a hydrogen storage system and a fuel cell system to reconvert the hydrogen to the electrical grid.

### III. PHOTOVOLTAIC TECHNOLOGY

This section focuses on a review of recent developments of power electronics converters and the state of art of implemented photovoltaic (PV) systems. PV systems as an alternative energy resource or energy resource complementary in hybrid systems have been becoming feasible due to the increase of research and development work in this area. In order to maximize the success of PV systems, high reliability, a reasonable cost, and user-friendly design must be achieved in the proposed PV topologies. Several standards given by the utility companies must be obeyed in the PV modules connection. Nowadays, the standards EN61000-3-2 [29], IEEE1547 [30] and the U.S. National Electrical Code (NEC) 690 [31], and the future international standard (still a Committee Draft for Vote- CDV) IEC61727 [32] are being considered. These standards deal with issues like power quality, detection of islanding operation, grounding, etc. They define the structure and the features of present and future PV modules.

#### A. Market Considerations

Solar Electric Energy demand has grown consistently by 20-25% per annum over the past 20 years, mainly due to the decreasing costs and prices. This decline has been driven by a) increasing efficiency of solar cells b) manufacturing technology improvements, and c) economies of scale. In 2001, 350 Megawatts of solar equipment were sold to add to the

solar equipment already generating clean energy. In 2003, 574 Megawatts of PV were installed. This increased to 927 Megawatts in 2004. The European Union is on track to fulfilling its own target of 3 GW of renewable electricity from photovoltaics for 2010 and in Japan, the target is 4.8 GW. If the growth rates of the installation of photovoltaic systems between 2001 and 2003 could be maintained in the next years, the target of the European Commission's White Paper for a Community Strategy and Action Plan on Renewable Sources of Energy would already be achieved in 2008. It is important to notice that the photovoltaic installation growth rate curve in the European Union exactly mirrors that of wind power, with a delay of approximately 12 years. This fact predicts a great future for PV systems in the coming years.

#### B. Design of PV Converters Families

An overview of some existing power inverter topologies for interfacing PV modules to the grid is presented. The approaches are further discussed and evaluated in order to recognize the most suitable topologies for future PV converters, and, finally, a conclusion is given.

Due to advances in transistor technology, the inverter topologies have changed from large thyristor-equipped grid-connected inverters to smaller insulated-gate-bipolar-transistor (IGBT) equipped ones. These transistors permit to increase the power switching frequency in order to extract more energy and fulfil the connecting standards. One requirement of standards is that the inverters must also be able to detect an islanding situation and take appropriate measures in order to protect persons and equipment [33]. In this situation, the grid has been removed from the inverter, which then only supplies local loads. This can be troublesome for many high-power transformerless systems, since a single-phase inverter with neutral-to-line grid connection is a system grounded on the grid side.

In general, PV cells can be connected to the grid (grid connection application) or they can be used as isolated power supplies. These two different applications of PV systems are shown in Fig. 10.

Several classifications of converter topologies can be done with respect to the number of power processing stages, location of power decoupling capacitors, use of transformers, and types of grid interface. However, before discussing PV converter topologies, three designs of inverter families are defined: central inverters, module-oriented or module-integrated inverters, and string inverters [34][35]. The central converters connect in parallel and/or in series on DC side. One converter is used for the entire PV plant (often divided into several units organized in master-slave mode). The nominal power of this topology is up to several MW. The module-oriented converters with several modules usually connect in series on DC side and in parallel on AC side. The nominal power ratings of such PV power plants are up to several MW. In addition, in the module-integrated converter topology one converter per PV module and a parallel connection on AC side are used. In this topology, a central measure for mains

supervision is necessary. Although this topology optimizes the energy yield, it has lower efficiency than the string inverter. This concept can be implemented for PV plants of about 50-100 W.

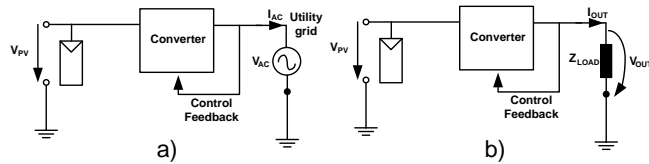

Fig. 10. PV energy applications: a) grid connection application b) power supply application

In Fig. 11, one-phase multi-string-converter (a) and three-phase multi-string-converter (b) are shown. A detail of a multi-string converter with a single-phase inverter stage is illustrated in Fig. 12.

The multi-string topology permits the integration of PV strings of different technologies and orientations (north, south, east and west).

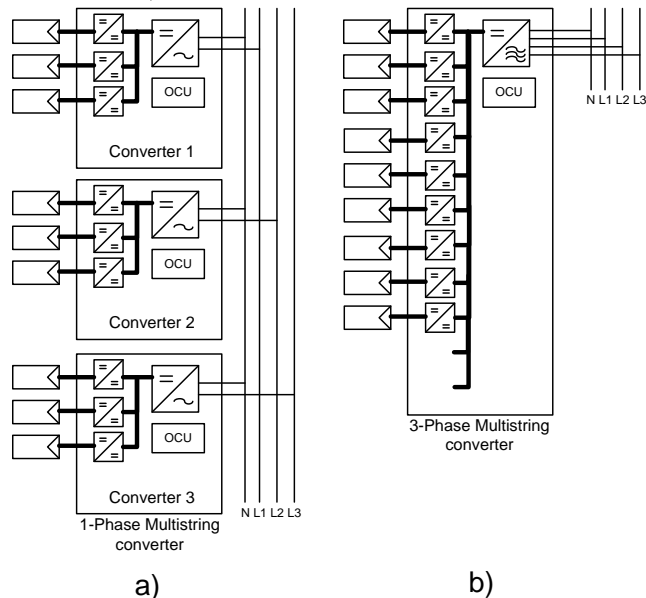

Fig. 11. (a) One-phase multi-string-converter and (b) Three-phase multi-string-converter

### C. Photovoltaic Topologies

Conventionally, classification of PV topologies is divided into two major categories: PV inverters with DC/DC converter (with or without isolation) and PV inverters without DC/DC converter (with or without isolation) [34][36].

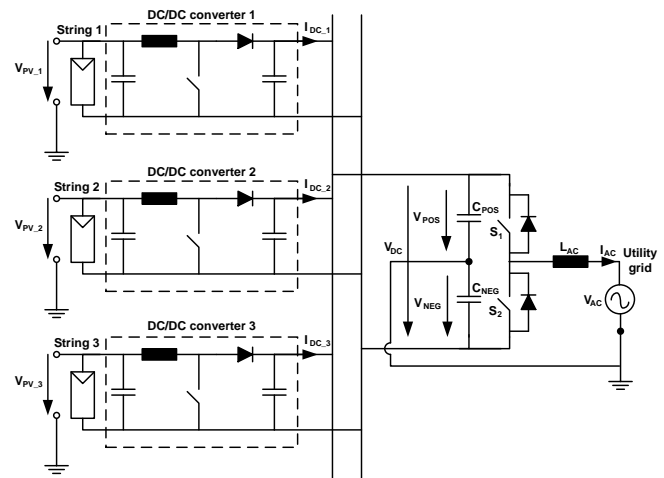

Fig. 12. Detail of a multi-string converter with a single-phase inverter stage

The isolation used in both categories is acquired using a transformer that can be placed on either the grid or low-frequency (LF) side or on the high-frequency (HF) side. The line-frequency transformer is an important component in the system due to its size, weight, and price. The HF transformer is more compact but special attention must be paid to reduce losses [34][37]. The use of a transformer leads to the necessary isolation (requirement in US) and modern inverters tend to use a high-frequency transformer. However, PV inverters with DC/DC converter without isolation are usually implemented in some countries where grid-isolation is not mandatory.

Basic designs focused on solutions for high frequency DC/DC converter topologies with isolation such as full-bridge or single inductor push-pull permit to reduce the transformer ratio providing higher efficiency together with smoother input current. However, a transformer with tap point is required. In addition, a double-inductor push-pull is implemented in other kind of applications (equivalent with two interleaved boost converters leading to lower ripple in the input current), but extra inductor is needed [38]. Full-bridge converter is usually used at power levels above 750 W due to its good transformer utilization [34].

Other possible classification of PV inverter topologies can be based on the number of cascade power processing stages. The single-stage inverter must handle all tasks such as Maximum Power Point Tracking (MPPT) control, grid current control, and voltage amplification. This configuration, useful for a centralized inverter, has some drawbacks because it must be designed to achieve a peak power of twice the nominal power. Another possibility is to use a dual-stage inverter. In this case, the DC/DC converter performs the MPPT (and perhaps voltage amplification) and the DC/AC inverter is dedicated to control the grid current by means of Pulse-Width Modulation (PWM), Space Vector Modulation (SVM) or bang-bang operation. Finally, multi-stage inverters can be used, as mentioned above. In this case, the task for each DC/DC converter is MPPT and normally, the increase of the DC voltage. The DC/DC converters are connected to the DC link of a common DC/AC inverter, which takes care for the grid current control. This is beneficial since better control of



each PV module/string is achieved and that common DC/AC inverter may be based on standard Variable Speed Drive (VSD) technology.

There is not any standard PV inverter topology. Several useful proposed topologies have been presented and some good studies regarding current PV inverters have been done [39][40]. The current control scheme is mainly used in PV inverter applications [41]. In these converters, the current into the stage is modulated/controlled to follow a rectified sinusoidal waveform and the task for the circuit is simply to re-create the sine wave and inject it into the grid. The circuits apply zero-voltage switching (ZVS) and zero-current switching (ZCS). Thus, only conduction losses of the semiconductors remain. If the converter has several stages, power decoupling must be achieved with a capacitor in parallel with the PV module(s). The current control scheme is employed more frequently, because a high power factor can be obtained with simple control circuits, and transient current suppression is possible when disturbances such as voltage changes occur in the utility power system. In the current control scheme, operation as an isolated power source is difficult but there are no problems with grid interconnection operation.

PV AC Modules inverters used to be dual-stage inverters with an embedded HF transformer. Classical solutions can be applied to develop these converters: Flyback converters (single or two transistors), Flyback with a Buck-Boost converter, resonant converters, etc.

For string or multi-string systems, the inverters used to be single or dual-stage inverters with an embedded HF transformer. However, new solutions try to eliminate the transformer using multilevel topologies.

A very common AC/DC topology is the half-bridge two-level Voltage Source Inverter (VSI), which can create two different voltage levels and requires double DC-link voltage and double switching frequency in order to obtain the same performance as the full bridge. In this inverter, the switching frequency must be double the previous one in order to obtain the same size of the grid inductor. A variant of this topology is the standard full-bridge three-level VSI, which can create a sinusoidal grid current by applying the positive/negative DC-link or zero voltage, to the grid plus grid inductor [42]. This inverter can create three different voltages across the grid and inductor, the switching frequency of each transistor is reduced, and good power quality is ensured. The voltage across the grid and inductor is usually pulse-width modulated but hysteresis (bang-bang) current control can also be applied.

Other multilevel topologies can be taken into account and in [43] cascade multilevel inverters are studied. Seven basic three-level cells can be used to achieve fifteen levels in the output signals without using an output transformer. This is beneficial for the power system and results in an improvement in the Total Harmonic Distortion (THD) performance of the output signals. However, other problems such as commutation and conduction losses appear [34].

#### D. Future Trends

The increasing interest and steadily growing number of investors in solar energy, stimulated research that resulted in development of very efficient PV cells, leading to universal implementations in isolated locations [44]. Due to improvement of roofing PV systems, residential neighbourhoods are becoming a target of solar panels and some current projects involve installation and set-up of PV modules in high building structures [45].

PV systems without transformers would be the most suitable option in order to minimize the cost of the total system. On the other hand, the cost of the grid-connected inverter is becoming more visible in the total system price. A cost reduction per inverter watt is, therefore, important to make PV-generated power more attractive. So, it seems that centralized converters would be a good option for photovoltaic systems. However, problems associated with the centralized control appear and it can be difficult to use this type of systems.

Increasing interest is being focused in Automatic Control (AC) modules that implement MPPT for PV modules improving the total system efficiency. The future of this type of topologies is to develop "plug and play systems" that are easy to install for non-expert users. This means that new AC modules may see the light in the future and they would be the future trend in this type of technology. The inverters must guarantee that the PV module is operated at the Maximum Power Point (MPP) thanks to use MPPT control increasing the PV systems efficiency. The operation around the MPP without too much fluctuation will reduce the ripple at the terminals of the PV module.

So, the control topics such as improvements of MPPT control, THD improvements, and reduction of current or voltage ripples will be the focus of researchers in the years to come [46]. These topics have been deeply studied during last years but some improvements still can be done using new topologies such as multilevel converters. In particular, multilevel cascade converters seem to be a good solution to increase the voltage in the converter in order to eliminate the high frequency transformer. Possible drawback of this topology is control complexity and increased number of solid-state devices (transistors and diodes). It should be noticed that the increase of commutation and conduction losses has to be taken into account while selecting PWM or SVM modulation algorithms.

Finally, it is important to remember that standards, regarding the connection of PV systems to the grid, are actually becoming more and more strict. So, the future PV technology will have to fulfil them, minimizing simultaneously the cost of the system as much as possible. In addition, the incorporation of new technologies, packaging techniques, control schemes and an extensive testing regimen must be developed. Testing is not only the part of each phase of development but also the part of validation of the final product [44].

## IV. STORAGE SYSTEMS

### A. Flywheels

In order to improve the quality of the generated power, as well as to support critical loads during mains power interruption, several energy storage technologies have been investigated, developed, proved, and implemented in renewable energy systems. However, flywheels are very commonly used due to the simplicity of storing kinetic energy in a spinning mass. For approximately 20 years it has been a primary technology used to limit power interruptions in motor/generator sets where steel wheels increase the rotating inertia providing short power interruptions protection and smoothing of delivered power. One of the first commercial uses of flywheels in conjunction with active filtering to improve frequency distortion on a high voltage power system line is described in [47].

There are two broad classes of flywheel energy storage technologies. One is a technology based on low-speed flywheels (up to 6000 rpm) with steel rotors and conventional bearings. The other one involves modern high-speed flywheel systems (up to 60000 rpm) that are just becoming commercial and make use of advanced composite wheels, which have much higher energy and power density than steel wheels. This technology requires ultra-low friction bearing assemblies, such as magnetic bearings, and stimulates a research trend [48].

Most applications of flywheels, in the area of renewable energy delivery, are based on a typical configuration where an electrical machine (i.e. high-speed synchronous machine or induction machine) drives a flywheel and its electrical part is connected to the grid via back-to-back converter, as shown in Fig. 13. Such configuration requires an adequate control strategy to improve power smoothing [49]-[52]. The basic operation could be summarized as follows. When there is excess in generated power with respect to the demanded power, the difference is stored in the flywheel that is driven by the electrical machine operating as a motor. On the other hand, when a perturbation or a fluctuation in delivered power is detected in the loads, the electrical machine is driven by the flywheel and operates as a generator, supplying needed extra energy. A typical control algorithm is a direct vector control with rotor flux orientation and sensorless control using Model Reference Adaptive System (MRAS) observer.

Experimental alternatives for wind farms include flywheel compensation systems connected to the DC link that are the same as systems used for power smoothing for a single or a group of wind turbines [53]. Usually, a control strategy is applied to regulate the DC voltage against input power surges/sags or sudden changes in load demand. A similar configuration can be applied to solar cells [54]. Another renewable energy resource where power oscillations need to be smoothed is wave energy. In [55], a D-STATCOM is proposed, as an alternative to flywheels, to accomplish the output power smoothing on a wave energy converter where several operating conditions should be taken into account.

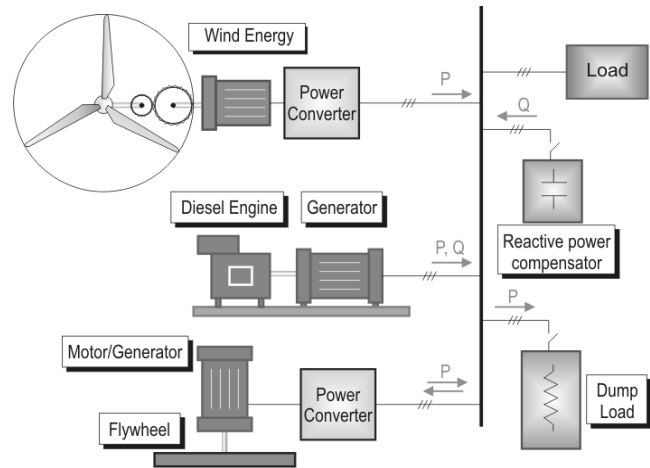

Fig. 13. Typical compensation system for renewable energy applications based on flywheel energy storage.

Recent proposals on using flywheels to regulate system frequency include the disposal of a matrix of several flywheels to compensate the difference between the network's load and power generated [56].

Recently, there are research works where integrated flywheel systems can be encountered. Those systems use the same steel rotor of the electrical machine as energy storage element [57]. Two of the main advantages of a system like that are its high power density and its similarity with a standard electrical machine. It seems that a new trend for energy storage in renewable energy systems is to combine several storing technologies (as occurs in UPS application), where a storage system integrates compressed-air system, thermal storage unit and flywheel energy storage [58].

### B. Hydrogen

The purpose of this section is to analyze new trends in hydrogen storage systems for high quality back-up power. The hydrogen-fuel economy has been rapidly increasing in industrial application due to the advantages of the hydrogen of being storable, transportable, highly versatile, efficient and clean energy carrier to supplement or replace many of the current fuel options. It can be used in fuel cells to produce electricity in a versatile way, for example in portable applications, stationary use of energy, transportation or high power generation. The use of fuel cells in such applications is justified since they are a very important alternative power source due to their well-known specific characteristics such as very low toxic emissions, low noise and vibrations, modular design, high efficiency (especially with partial load), easy installation, compatibility with a lot of types of fuels, and low maintenance cost.

The increase of the penetration of renewable energies worldwide, make the storage issue critical both in stand-alone [59] and grid-connected application. An example of the hydrogen storage application to improve the grid power quality through smoothing large and quick fluctuations of wind energy is reported in [60].

Hydrogen could be stored as compressed or liquefied gas [61] or by using metal hydrides or carbon nanotubes [62]. For a particular application, the choice of a storage technology implies a trade off between the characteristics of available technologies in terms of technical, economical or environmental performance [63]. Applications must also include a discussion of the lifecycle efficiency and cost of the proposed storage system. This analysis should consider the total life of the proposed hydrogen storage system including: raw material requirements, manufacturing and fabrication processes, integration of the system into the vehicle or off-board configuration, useful service life, removal and disposal processes including recycling. Recently, research and development are focused on new materials or technologies for hydrogen storage: metal hydrides (reduce the volumetric and pressure requirements for storage, but they are more complex than other solutions), chemical hydrides, and carbon-based hydrogen storage materials, compressed and liquid hydrogen tank technologies, off-board hydrogen storage systems (a typical refuelling station will be delivering 200-1500 kg/day of hydrogen) and new materials and approaches for storing hydrogen on-board a vehicle. Applications to identify and investigate advanced concepts for material storage that have the potential to achieve 2010 targets of 2 kWh/kg and 1.5 kWh/L.

#### C. Compressed Air Energy Storage (CAES)

Energy storage in compressed air is made using a compressor, which stores it in an air reservoir (i.e. an aquifer like ones used for natural gas storage, natural caverns or mechanically formed caverns, etc.). When a grid is operating off-peak, the compressor stores air in the air reservoir. During discharge at peak loads, the compressed air is released to a combustor where it is mixed with oil or gas driving a gas turbine. Such systems are available for 100-300 MW and burn about one-third of the premium fuel of a conventional simple cycle combustion turbine.

An alternative to CAES is the use of compressed air in vessels (called CAS), which operates exactly in the same way as CAES except that the air is stored in pressure vessels, rather than underground reservoirs. Such difference makes possible variations consisting of the use of pneumatic motor acting as compressors or driving a DC motor/generator, according to the operation required by the system, i.e., storing energy when there is no extra demand of energy or delivering extra power at peak loads.

Recent research is devoted to maximum efficiency point tracking control [64] or integrated technologies for power supplies applications [65].

#### D. Supercapacitors

Supercapacitors, also known as ultracapacitors or electric double layer capacitors (EDLC), are built up with modules of single cells connected in series and packed with adjacent modules connected in parallel. Single cells are available with capacitance values from 350F to 2700F and operate in the

range of the 2V. The module voltage is usually in the range from 200V to 400V. They have a long life cycle and are suitable for short discharge applications and less than 100kW. New trends focused on using ultracapacitors to cover temporary high peak power demands [66], integration with other energy storage technologies and development of high-voltage applications.

#### E. Superconducting Magnetic Energy Storage (SMES)

In a SMES, a coil of superconducting wire stores electrical energy in a magnetic field without resistive losses. Also, there is no need for conversion between chemical or mechanical forms of energy.

Recent systems are based on both general configurations of the coil: solenoidal or toroidal. The second topology has minimal external magnetic field but the cost of superconductor and coil components is higher than for the first topology. Such devices require cryogenic refrigerators (to operate in liquid helium at  $-269^{\circ}\text{C}$ ) besides the solid-state power electronics.

The system operates by injecting a DC current into the superconducting coil, which stores the energy in magnetic field. When a load must be fed, the current is generated using the energy stored in the magnetic field. One of the major advantages of SMES is the ability to release large quantities of power during a fraction of a cycle. Typical applications of SMES are corrections of voltage sags and dips at industrial facilities (1MW units) and stabilization of ring networks (2MW units).

New trends in SMES are related to the use of low-temperature superconductors (liquid nitrogen temperature), the use of secondary batteries, and the integration of static synchronous compensator (STATCOM) [67] and several topologies of AC-DC-AC converters with SMES [68].

#### F. Battery Storage

The use of batteries as a system to interchange energy with the grid is well known. There are several types of batteries used in renewable energy systems: lead acid, lithium and nickel.

Batteries provide rapid response for either charge or discharge, although the discharge rate is limited by chemical reactions and type of battery. They act as a constant voltage source in power systems. New trends in the use of batteries for renewable energy systems focused on the integration with several energy sources (wind energy, photovoltaic systems, etc.) and also on the integration with other energy storage systems complementing them. Also, there are attempts to optimize battery cells in order to reduce maintenance and to increment its lifetime [69].

#### G. Pumped – Hydroelectric Storage (PHS)

As batteries, PHS is a mature technology where a swamp of water stored at a certain high elevation is used to generate electric energy by hydroturbines, whenever there is an additional power demand in the grid. When no extra generation is needed, the water is pumped back up to recharge

the upper reservoir. One limitation of PHS is that they require significant land areas with suitable topography. There are units with sizes from 30 MW to 350MW, with efficiencies around 75%.

New trends in PHS are focused on the integration with variable speed drives (cycloconverters driven doubly-fed induction machine) [70] and the use of underground pumped hydroelectric storage (UPHS), where the lower reservoir is excavated from subterranean rock. Such a system is more flexible, more efficient, but requires a higher capital cost.

## V. CONCLUSION

The new power electronics technology plays a very important role in the integration of renewable energy sources into the grid. It should be possible to develop the power electronics interface for the highest projected turbine rating; optimize energy conversion and transmission and control reactive power; minimize harmonic distortion; achieve at a low cost high efficiency over a wide power range; have a high reliability and tolerance to the failure of a subsystem component.

In this paper, the common and future trends for renewable energy systems have been described. As current energy source, wind energy is the most advanced technology due to its installed power and the recent improvements of the power electronics and control. In addition, the applicable regulations favour the increasing number of wind farms due to the attractive economical reliability. On the other hand, the trend of the photovoltaic energy leads to consider that it will be an interesting alternative in the near future when the current problems and disadvantages of this technology (high cost, low efficiency) are solved. Finally, for the energy storage systems (flywheels, hydrogen, compressed air, supercapacitors, superconducting magnetic and pumped-hydroelectric) the future presents several fronts and actually they are in the same development level. These systems are nowadays being studied and only research projects have been developed focused on the achievement of mature technologies.

## WIND ENERGY REFERENCES

- [1] S. Heier, *Grid Integration of Wind Energy Conversion Systems*. John Wiley & Sons, 1998.
- [2] G.L. Johnson, *Wind Energy Systems*. Prentice-Hall, INC., 1985.
- [3] S. Muller, M. Deicke, R. W., and De Doncker, "Doubly fed induction generator systems for wind turbines". *Industry Applications Magazine, IEEE*. Volume 8, Page(s):26 – 33, May-June 2002
- [4] F. M. Hughes, O. Anaya-Lara, N. Jenkins, and G. Strbac, "Control of DFIG-based wind generation for power network support". *Power Systems, IEEE Transactions on* Volume 20, Issue 4, Page(s):1958 – 1966, Nov. 2005.
- [5] M. Orabi, F. El-Sousy, H. Godah, and M. Z. Youssef, "High-performance induction generator-wind turbine connected to utility grid", presented at Telecommunications Energy Conference, 2004. INTELEC 2004. 26th Annual International, Page(s):697 – 704, 19-23 Sept. 2004
- [6] J.M. Peter, "Main Future Trends for Power Semiconductors from the State of the Art to Future Trends", presented at Power Conversion Intelligent Motion (PCIM'99). Nürnberg. June 1999.
- [7] H. Grüning et Al. "High Power Hard-Driven GTO Module for 4.5kV/3kA Snubberless operations", presented at PCI Europe Proceedings Number 1996.

- [8] E.ON Netz Grid Code, Bayreuth; E.ON Netz GmbH. Germany, 1 Aug. 2003.
- [9] D. Foussekis, F. Kokkalidis, S. Tentzevakis, and D. Agoris, "Power quality measurement on different type of wind turbines operating in the same wind farm", presented at EWEC 2003.
- [10] International Electrotechnical Commission, IEC Standard, Amendment 1 to Publication 61000-4-7, Electromagnetic Compatibility, General Guide on Harmonics and Inter-harmonics Measurements and Instrumentation, 1997.
- [11] International Electrotechnical Commission, IEC Standard, Publication 61000-3-6, Electromagnetic Compatibility, Assessment of Emission Limits for Distorting Loads in MV and HV Power Systems, 1996.
- [12] Larsson Ake, Sorensen Poul and Santjer Fritz. "Grid impact of variable speed wind turbines", presented at EWEC' 99.
- [13] N. Kirby, L. Xu, M. Lockett, and W. Siepmann, "HVDC transmission for large offshore wind farms", *Power Engineering Journal*, vol. 16, pp. 135-141, June 2002.
- [14] K. Eriksson, C. Liljegren, and K. S\_brink, "HVDC Light Experiences applicable for power transmission from offshore wind power parks," No. AIAA-2004-1010, Published by the American Institute of Aeronautics, 2004.
- [15] S. Meier, "Novel Voltage Source Converter based HVDC Transmission System for Offshore Wind Farms", PhD dissertation, Department of Electrical Engineering, Royal Institute of Technology, Stockholm, Sweden, 2005.
- [16] R. Swisher, C.R. de Azua, and J. Clendenin: "Strong Winds on the Horizon: Wind Power Comes on Age" Proceedings of the IEEE, Volume 89, Issue 12, Pages 1757-1764
- [17] S. Bum-Seok, G. Sinha, M. D. Manjrekar, and T. A. Lipo, "Multilevel Power Conversion – An Overview of Topologies and Modulations Strategies" in *Proceedings of the International Conference on Optimization of Electrical and Electronic Equipments*, 1998. OPTIM '98. Volume 2, Page(s):AD-11 – AD-2
- [18] L. M. Tolbert, Fang Zheng Peng, and T. G. Habetler, "Multilevel converters for Large Electric drives" *IEEE Transactions on Industry Applications*, Volume 35, Issue 1, Page(s):36 - 44
- [19] J. Rodriguez, Jih-Sheng Lai, and Fang Zheng Peng, "Multilevel inverters: a survey of topologies, controls, and applications", *IEEE Transactions on Industrial Electronics*, Volume 49, Issue 4, Aug. 2002 Page(s):724 – 738
- [20] M. Marchesoni, and M. Mazzucchelli, "Multilevel converters for high power AC drives: a review", in *Proc. IEEE International Symposium on Industrial Electronics, ISIE'93 - Budapest.*, Page(s):38 – 43, 1993
- [21] G. Escobar, J. Leyva-Ramos, J. M. Carrasco, E. Galvan, R. C. Portillo, M. M. Prats, and L. G. Franquelo; "Control of a Three Level Converter used as a Synchronous Rectifier", in *Proc. IEEE Power Electronics Specialist Conference, PESC'04 – Aachen*, Pages 3458-6464, 2004
- [22] G. Escobar, J. Leyva-Ramos, J. M. Carrasco, E. Galvan, R. C. Portillo, M. M. Prats, and L. G. Franquelo; "Modeling of a Three Level Converter used as a Synchronous Rectifier" in *Proc. IEEE Power Electronics Specialist Conference, PESC'04 – Aachen*, Pages 4606-4611, 2004
- [23] R. Portillo, M. M. Prats, J. I. Leon, J. A. Sanchez, J. M. Carrasco, E. Galvan, and L. G. Franquelo; "Modeling Strategy for Back-To-Back Three Level Converters Applied to High Power Wind Turbines", *IEEE Transactions on Industrial Electronics*, to be published.
- [24] M. A. Khan, P. Pillay, and M. Malengret, "Impact of direct-drive WEC Systems on the design of a small PM wind generator", in *Proc. Power Tech Conference IEEE, Bologna* Volume 2, Page(s):7 pp., Vol.2, 23-26 June 2003.
- [25] I. Schiemenz, and M. Stiebler, "Control of a permanent magnet synchronous generator used in a variable speed wind energy system" presented at Electric Machines and Drives Conference, 2001. IEMDC 2001. IEEE International. 2001 Page(s):872 – 877.
- [26] Liuchen Chang, Qincy Wang, and Pinggang Song. "Application of finite element method in design of a 50 kW direct drive synchronous generator for variable speed wind turbines", presented at Power Electronics and Motion Control Conference, 2004. IPEMC 2004. The 4th International Volume 2, 14-16 Aug. 2004 Page(s):591 - 596 Vol.2.
- [27] J. R. Bumby, and R. Martin, "Axial-flux permanent-magnet air-cored generator for small-scale wind turbines" in *Proc. Electric Power*

Applications, IEE Volume 152, Issue 5, 9 Sept. 2005 Page(s):1065 - 1075

- [28] "Advanced electricity storage technologies programme. Energy Storage Technologies: a review paper". Published by the Australian Greenhouse Office, Department of the Environment and Heritage, December 2005. Available: <http://www.greenhouse.gov.au/renewable/aest/pubs/aest-review.pdf>

#### PHOTOVOLTAIC REFERENCES

- [29] *Limits for Harmonic Current Emission (Equipment Input Current < 16A per Phase)*, EN 61000-3-2, 1995.
- [30] *IEEE Standard for Interconnecting Distributed Resources With Electric Power Systems*, IEEE Std. 1547, 2003.
- [31] *2002 National Electrical Code*, National Fire Protection Association, Inc., Quincy, MA, 2002.
- [32] *Characteristics of the Utility Interface for Photovoltaic (PV) systems*, IEC 61727 CDV (Committee Draft for Vote), 2002.
- [33] B. Verhoeven et Al., "Utility Aspects of Grid Connected Photovoltaic Power Systems", International Energy Agency Photovoltaic Power Systems, IEA PVPS T5-01: 1998. Available: [www.iea-pvps.org](http://www.iea-pvps.org)
- [34] F. Blaabjerg, R. Teodorescu, Z. Chen and M. Liserre, "Power converters and control of renewable energy systems", in *Proc. The 6-th International Conference on Power Electronics*, 18-22 October 2004 (plenary session).
- [35] J. M. A. Myrzik and M. Calais, "String and module integrated inverters for single-phase grid connected photovoltaic systems - a review", in *Proc. IEEE Power Tech Conference*, Bologna, 23-26 June 2003, vol. 2.
- [36] H. Haeblerlin, "Evolution of Inverters for Grid connected PV systems from 1989 to 2000", in *Proc. Photovoltaic Solar Energy Conference*, 2001.
- [37] M. Z. Ramli, Z. Salam, L. S. Toh, and C. L. Nge, "A bidirectional inverter with high frequency isolated transformer", in *Proc. Power Engineering Conference*, National, 15-16 Dec., 2003, pp. 71 – 75.
- [38] R. W. Erickson, and D. Maksimovic, *Fundamentals of Power Electronics*, Kluwer Academic Pub., March 1, 1997.
- [39] S. B. Kjaer, J. K. Pedersen, and F. Blaabjerg, "A review of single-phase grid-connected inverters for photovoltaic modules", *IEEE Transactions on Industry Applications*, Vol. 41, Issue 5, pp. 1292 – 1306, Sept.-Oct. 2005.
- [40] S. B. Kjaer, J. K. Pedersen, and F. Blaabjerg, "Power inverter topologies for photovoltaic modules-a review", in *Conf. Rec. 37th Industry Applications Conference Annual Meeting*, Volume 2, pp. 782 – 788, 13-18 Oct., 2002.
- [41] "Implementing Agreement on Photovoltaic Power Systems. Grid-connected photovoltaic power systems: survey of inverter and related protection equipments", International Energy Agency. Central Research Institute of Electric Power Industry, IEA PVPS T5-05, Dec. 2002.
- [42] H. Nabae, Akagi and I. Takahashi, "A New Neutral-Point-Clamped PWM Inverter", *IEEE Transactions on Industry Applications*, Vol. IA-17, NO. 5, pp.518-523, September/October 1981.
- [43] Feel-Soon Kang, Sung-Jun Park, Su Eog Cho, Cheul-U Kim, and T. Ise, "Multilevel PWM inverters suitable for the use of stand-alone photovoltaic power systems", *IEEE Transactions in Energy Conversion*, Vol. 20, Issue 4, pp. 906 – 915, Dec. 2005.
- [44] R. H. Bonn, "Developing a "next generation" PV inverter", in *Proc. Photovoltaic Specialists Conference*, 19-24 May 2002, pp. 1352 – 1355.
- [45] Subhendu Guha, "Can your roof provide your electrical needs? – The growth prospect of building-integrated photovoltaic", in *Conf. Rec. Thirty-first IEEE Photovoltaic Specialists Conference*, 3-7 Jan. 2005. pp: 12 – 16.
- [46] M. Liserre, R. Teodorescu, and F. Blaabjerg, "Stability of grid-connected PV inverters with large grid impedance variation", in *Proc. Power Electronics Specialists Conference*, 2004. PESC 04, vol. 6, pp.4773-4779, 20-25 June 2004

#### RENEWABLE ENERGY GENERATORS AND ENERGY STORAGE REFERENCES

- [47] H. Akagi, "Active filters and energy storage systems for power conditioning in Japan", in *Proc. of the First International Conference on Power Electronics Systems and Applications*, 2004, pp. 80 – 88.
- [48] R. de Andrade, Jr., A. C. Ferreira, G. G. Sotelo, J. L. Silva Neto, L. G. B. Rolim, W. I. Suemitsu, M. F. Bessa, R. M. Stephan, and R. Nicolsky, "Voltage Sags Compensation Using a Superconducting Flywheel Energy Storage System", *IEEE Transactions on Applied Superconductivity*, vol. 15, nr. 2, pp. 2265–2268, Jun. 2005
- [49] R. Cárdenas, G. Asher, R. Peña, and J. Clare, "Power smoothing control using sensorless flywheel drive in wind-diesel generation systems", in *Proc. of IEEE 28th Annual Conference on Industrial Electronics, Control and Instrumentation (IECON'02)*, Sevilla, 2002.
- [50] I. J. Iglesias, L. Garcia-Tabares, A. Agudo, I. Cruz, and L. Arribas, "Design and simulation of a stand-alone wind-diesel generator with a flywheel energy storage system to supply the required active and reactive power", in *Proc. of the IEEE 31st Annual Power Electronics Specialists Conference (PESC 00)*, pp. 1381 –1386, 2000.
- [51] Jian Wan, Longyun Kang, Liuchen Chang, Binggang Cao, and Daming Xu, "Energy complementary control of a distributed power generation system based on renewable energy", *Proc. of 2004 Large Engineering systems Conference on Power Engineering*, July 2004, pp. 136 – 140.
- [52] J. L. da Silva Neto, L. G. B. Rolim, and G. G. Sotelo, "Control of power circuit interface of a flywheel-based energy storage system", in *Proc. of the 2003 IEEE International Symposium on Industrial Electronics*. Vol. 2, June 2003, pp. 962 – 967.
- [53] R. Cárdenas, R. Peña, G. Asher, and J. Clare, "Control strategies for enhanced power smoothing in wind energy systems using a flywheel driven by a vector-controlled induction machine", *IEEE Trans. on Industrial Electronics*, Vol. 48, nr. 3, June 2001, pp. 625–635.
- [54] Istvan Vajda, Zalan Kohari, Laszlo Benko, Victor Meerovich, and Wolfgang Gawalek, "Investigation of Joint Operation of a Superconducting Kinetic Energy Storage (Flywheel) and Solar Cells", *IEEE Transactions On Applied Superconductivity*, Vol. 13, Nr. 2, June 2003, pp. 2169–2172.
- [55] M. Barnes, R. El-Feres, S. Kromlides, and A. Arulampalam, "Power quality improvement for wave energy converters using a D-STATCOM with real energy storage", in *Proc. of the 2004 First International Conference on Power Electronics Systems and Applications*, Nov. 2004, pp. 72 – 77.
- [56] M. L. Lazarewicz, and A. Rojas, "Grid frequency regulation by recycling electrical energy in flywheels", in *Proc. of the IEEE Power Engineering Society General Meeting*, Vol. 2, June 2004, pp. 2038 – 2042.
- [57] Perry Tsao, Matthew Senesky, and Seth R. Sanders, "An Integrated Flywheel Energy Storage System With Homopolar Inductor Motor/Generator and High-Frequency Drive", *IEEE Transactions On Industry Applications*, Vol. 39, nr. 6, November/December 2003, pp. 1710–1725.
- [58] J.R. Sears, "TEX: the next generation of energy storage technology", in *Proc. of the 26th Annual International Telecommunications Energy Conference*, Sept. 2004, pp. 218 – 222.
- [59] K. Agbossou, M. Kolhe, J. Hamelin and T. K. Bose, "Performance of a stand-alone renewable energy system based on energy storage as hydrogen", *IEEE Transactions on Energy Conversion*, Vol 19, Issue 3, 2004, pp.633–640.
- [60] M. Nitta, S. Hashimoto, N. Sekiguchi, Y. Kouchi, T. Yachi and T. Tani, "Experimental study for wind power- hydrogen energy system with energy capacitor system", in *Proc. IEICE/IEEE INTELEC Conf.*, 2003, pp.451-456.
- [61] H. Walter, S. Arsac, J. Bock, S. O. Siems, W. R. Candlers, A. Leenders, H. C. Freyhardt, H. Fieseler and M. Kesten, "Liquid hydrogen tank with cylindrical superconducting bearing for automotive application", *IEEE Transactions on Applied Superconductivity*, Vol 13, Issue 2, Part 2, 2003, pp. 2150 – 2153.
- [62] A. S. Biris, A. R. Biris, D. Lupu, D. Buzatu, J. Darsey, and M. K. Muzumder, "Use of carbon nanostructures for hydrogen storage for environmentally safe automotive applications", in *Proc. Industry Applications Conference, 2004. 39th IAS Annual Meeting. Conference*, Vol. 2, 2004, pp. 953 – 956.

- [63] A. Von Jouanne, I. Husain, A. Wallace and A. Yokochi, "Gone with the wind" *IEEE Trans. Industry Applications Magazine*, July/Aug 2005.
- [64] S. Lemofouet, and A. Rufer, "Hybrid Energy Storage Systems based on Compressed Air and Supercapacitors with Maximum Efficiency Point Tracking", in *Proc. of the EPE'05*, Dresden, Sep. 2005.
- [65] J. R. Sears, "TEX: The next generation of energy storage technology", in *Proc. of the 26<sup>th</sup> Annual International Telecommunications Energy Conference*, pp. 218–222, 2004
- [66] T. Peppel, "Elimination of high power delivery rates by energy storage in supercapacitors", in *Proc. of the EPE'05*, Dresden, Sep. 2005.
- [67] M. G. Molina, P. E. Mercado, and E. H. Watanabe, "Dynamic Performance of a Static Synchronous Compensator with Superconducting Magnetic Energy Storage", in *Proc. of the PESC'05, Recife, Brasil*, Jun. 2005.
- [68] S. Nomura, Y. Ohata, T. Hagita, H. Tsutsui, S. Tsuji-Iio, and R. Shimada, "Wind farms linked by SMES systems", *IEEE Trans. on App. Superconductivity*, Vol. 15, Issue 2, Part 2, Jun. 2005, pp. 1951 - 1954.
- [69] P. Lailler, "Investigation on Storage Technologies for Intermittent Renewable Energies: Evaluation and recommended R&D strategy", Investire-network, Switzerland, Tech. Rep. ENK5-CT-2000-20336 WP-ST1, Feb. 2003.
- [70] A. Blocquel, and J. Janning, "Analysis of a 300MW Variable Speed Drive for Pump-Storage Plant Applications", in *Proc. of the EPE'05, Dresden*, Sep. 2005.

**Juan M. Carrasco** (M'97) was born in San Roque, Spain. He received the M.Eng. and Dr. Eng. degrees in industrial engineering from Sevilla University, Sevilla, Spain, in 1989 and 1992, respectively. He was an Assistant Professor from 1990 to 1995, and is currently an Associate Professor with the Department of Electronic Engineering, Sevilla University. He has been working for several years in the power electronic field where he was involved in industrial application for the design and development of power converters applied to renewable energy technologies. His current research area is distributed power generation and the integration of renewable energy sources.

**Leopoldo Garcia Franquelo** (M'84, S'96, F'05) received the Ing. and Dr. Ing. Industrial degrees from the Sevilla University, Sevilla, Spain in 1977 and 1980 respectively. He is currently a professor with the Department of Electronics Engineering at Sevilla University. His current interest include Industrial Applications of Electronics Power Converters.

**Jan T. Bialasiewicz** received M.S. degree from the Warsaw University of Technology, Poland and earned his Ph.D. and D.Sc. degrees from the Silesian University of Technology, Poland, all in Electrical Engineering. He is currently an Associate Professor in the Electrical Engineering Department, University of Colorado at Denver and Health Sciences Center, Denver, Colorado.

His research interests include control theory, modeling and identification of dynamic systems, renewable energy systems and theory and applications of wavelets. He is the author of two books and numerous research publications. He is an Associate Editor of IEEE Transactions on Industrial Electronics.

**Eduardo Galvan** was born in Aracena (Huelva), Spain, in 1964. He received the M.Sc. degree in electrical engineering and the Ph.D. degree in industrial engineering from the University of Sevilla, Sevilla, Spain, in 1991 and 1994, respectively.

He is an Associate Professor of electronic engineering at the Escuela Superior de Ingenieros, Sevilla. He has been working for several years in the power electronic field where he was involved in the industrial application for the design and development of power converters applied to renewable energy technologies. His research interests include control of power converters (wind turbine applications, active filters, and electric machines).

**Ramón C. Portillo** was born in Sevilla, Spain, in 1974. He received the Ingeniero Industrial degree from the University of Sevilla, Sevilla, Spain, in 2002, and he is currently pursuing the Ph. D. degree in electrical engineering at the Power Electronics Group, University of Sevilla, Sevilla, Spain. In 2001, he joined the Power Electronics Group, University of Sevilla, working in I+D projects. Since 2002, he has been an Associate Professor of the Department of Electronic Engineering, Sevilla University. His interest include electronic power systems applied to energy conditioning and generation, the power

quality in renewable generation plants, applications of fuzzy systems in industry and wind farms, modelling and control of power electronic converters and industrial drives.

**M<sup>a</sup>Ángeles Martín Prats** was born in Seville, Spain, in 1971. She received the Licenciado and Doctor degrees from the University of Sevilla, Spain in 1996 and 2003, respectively, both in physics.

In 1996 she joined the Spanish INTA (Aerospatial Technical National Institute), where she was working in the Renewable Energy Department. In 1998, she joined the Department of Electrical Engineering, University of Huelva, Spain. Since 2000, she has been an Assistant Professor with Electronic Engineering Department, University of Sevilla, Spain. Her research interest focuses on multilevel converters and fuel cell power conditioner systems. She is involved in industrial application for the design and development of power converters applied to renewable energy technologies.

**José I. León** was born in Cádiz, Spain, in 1976. He received the Telecommunications Engineer degree from the University of Sevilla, Spain, in 2001, and he is currently pursuing the Ph. D. degree in electrical engineering at the Power Electronics Group, University of Sevilla. In 2002, he joined the Power Electronics Group, University of Sevilla, working in I+D projects. Since 2002, he has been an Associate Professor of the Department of Electronic Engineering, Sevilla University. His interests include electronic power systems, modelling and control of power electronic converters and industrial drives and power quality in renewable generation plants.

**Narciso Moreno-Alfonso** (B'94–M'00) was born in Sevilla (Spain) on 1971. He received a Ingeniero Técnico Industrial degree in Electrical Engineering in 1994, and Ingeniero en Electrónica degree in 2000, all from the University of Sevilla, Sevilla, Spain. The author's major field of study is the application of power electronics to distributed generation, renewable energy systems and drives. He is Profesor Titular de Escuela Universitaria at the Dep. of Electric Engineering at the University of Sevilla since 1994. Since 2002 his research activity is developed at the Electronic Technology Group (GTE) at the Dep. of Electronic Engineering, Escuela Superior de Ingenieros, University of Sevilla, Spain.