New Computational Techniques for Solar Radiation in Architecture

Jose M. Cabeza-Lainez, Jesus A. Pulido Arcas, Carlos Rubio Bellido,
Manuel-Viggo Castilla, Luis Gonzalez-Boado and
Benito Sanchez-Montanes Macias

Additional information is available at the end of the chapter

<http://dx.doi.org/10.5772/60017>

1. Introduction

Many architectural examples rank among masterpieces for its beautiful and harmonious use of solar radiation. However, their creation had to rely solely on intuition because they possessed a curvilinear nature. As the necessary tools required for evaluating shapes derived from the sphere or the circle were not available, such forms could not be assessed.

Circular emitters represent an important issue not merely in architecture but in the field of configuration factors calculation. The circle form is present in a variety of devices and emitters that find ample application in the realms of thermal engineering, daylighting in architecture and artificial light, amongst others. In the past, several factors have been found for specific positions of the unit area in relation to the sources of such surface, centered with respect to the circle, but not for a generic location whether parallel or inclined. In this respect, perpendicular semicircles have been totally disregarded. As a result, calculation for the said configuration factors was sustained by iterative methods, which do not provide the desired accuracy in every situation and also require considerable effort and time in terms of computational capacity.

In previous researches, new configuration factors have been devised for complex forms and shapes, such as the paraboloid, the ellipsoid, the sphere and the straight cone, which are ever present in architecture and engineering. What is more, several configurations of volumes that include similar elements could also be assessed by virtue of adroit mathematical deduction. As a result, researchers and designers were provided with new configuration factors, so that the design process is entirely freed from iterative methods.

In this chapter, an exact analytical solution derived from complex double integration is presented. The expression obtained significantly soothes the calculation of the configuration factor between a circular emitter and a point that lies in a plane located at any position to the former, not only in an axis perpendicular to its center. Those results were checked against more conventional formulas. Based on such calculus procedures, an entirely new factor for the semicircle to a perpendicular plane that contains the straight edge has been deducted. Likewise, the solution has been converted into an original algorithm and programmed in simulation software developed by the authors so that interactive maps of the radiative field can be visualized in a consistent and accurate way. Thus, computer simulation techniques, engineering and image applications will be greatly enhanced and benefitted.

2. Outline of the problem & objectives

The reciprocity principle enunciated by Lambert in his paramount book *Photometria*, written in Latin (Lambert, 1760), yields the following well-known integral equation:

$$\phi_{1-2} = (E_{b1} - E_{b2}) \iint_{A_1, A_2} \cos\theta_1 \cdot \cos\theta_2 \cdot \frac{dA_1 \cdot dA_2}{\pi r^2} \tag{1}$$

Relevant terms in equation (1) are depicted in figure 1.

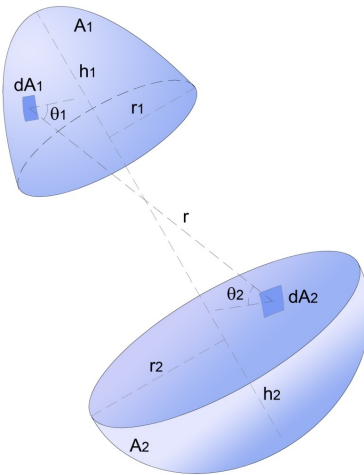

$$d\phi_{1-2} = (E_{b1} - E_{b2}) \cdot \cos\theta_1 \cdot \cos\theta_2 \cdot \frac{dA_1 \cdot dA_2}{\pi \cdot r^2}$$

Figure 1. The reciprocity principle and quantities' significance for surfaces A₁ and A₂

From the times of Lambert to our days, researchers and scientists in the fields of Geometric Optics and Radiative Transfer have striven to provide solutions for the canonical equation 1. This is no minor feat, since the said equation will lead in most cases to a quadruple integration and to be sure the fourth degree primitive of even simple mathematical expressions implies lengthy calculations. For this reason, direct mathematical calculation of circular emitters was avoided, and only expressions for some particular position with respect to the emitter were available. In this sense, a detailed catalogue of configuration factors is provided online in [1], but with respect to circular emitters, only specific ones where the receiving point location is restricted to an axis passing through the center of the emitting circle are included[2],[3].

Considering the importance of these emitters and its wide application in architectural design and engineering, the objectives of the research aimed at establishing precise mathematical expressions for the required configuration factors. Such procedure entails exact analytical solutions of the quadruple integral, in order to yield expressions that barely include geometric parameters.

That said, a circular source that emits with constant power has been considered; receiving points are located freely in any parallel or inclined plane. Starting from canonical equation (1) and following mathematical procedures, new configuration factors are developed for these surfaces.

3. Integration process for circular emitters

3.1. Direct integration for a differential element to a circular disk on a plane parallel to that of the element

Let us consider the proposed figure. In order to determine the radiant interchange between an emitting circle, which lies in the plane ZX, and a point P situated in another parallel plane XY, the following coordinate system is proposed (Figure 2).

Terms depicted in figure 2 are:

d: vertical distance between the center of the emitting circle and the plane XY.

b: horizontal distance between differential element dA_1 and the plane ZX that contains the said circle.

r: Emitting surface radius.

S: Distance between differential elements (in the canonical equation (1) of the configuration factor, it is denoted as r, but in order to differentiate it from radius of the disk (emitting surface, r), we shift to this denomination).

According to figure 2, the differential element dA_2 is expressed in terms of r and θ . Thus, to receive a proper integral, the rest of elements inside the integration sign of the canonical equation (1) should be expressed using the said variables. Basic construction for this expression

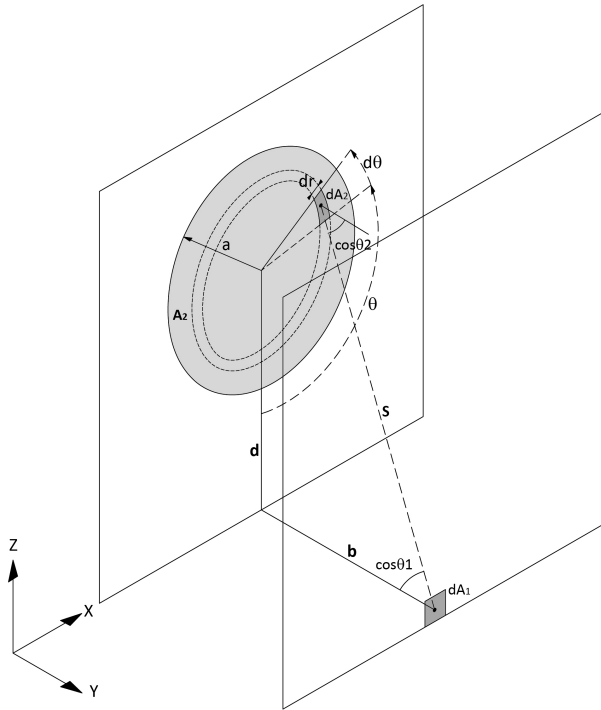

Figure 2. Calculation parameters for the parallel plane.

can be found in numerous manuals of radiative transfer [4]. Furthermore, mathematical support for the integration process is described in references [5]

dA_1 represents the point source

$$dA_2 = r dr d\theta \tag{2}$$

$$\cos \theta_1 = \frac{(d + r \cos \theta)}{S} \tag{3}$$

$$\cos \theta_2 = \frac{b}{S} \tag{4}$$

$$S = r^2 + d^2 + b^2 - 2dr \cdot \cos \theta \tag{5}$$

Substituting terms from (2) in accordance to figure 2, in the canonical equation of radiative transfer (1), the main integral that we need to solve is,

$$\int_{A_1} \int_{A_2} \cos\theta_1 \cdot \cos\theta_2 \cdot \frac{dA_1 \cdot dA_2}{\pi \cdot r^2} = \int_0^a \int_0^{2\pi} \frac{br \cdot (b - r \cdot \cos\theta)}{(r^2 + d^2 + b^2 - 2dr \cdot \cos\theta)^2} d\theta dr \quad (6)$$

Operating in the numerator we can decompose this integral in two parts:

$$\int_0^a \int_0^{2\pi} \frac{b^2 r}{(r^2 + d^2 + b^2 - 2dr \cdot \cos\theta)^2} d\theta dr - \int_0^a \int_0^{2\pi} \frac{br^2 \cdot \cos\theta}{(r^2 + d^2 + b^2 - 2dr \cdot \cos\theta)^2} d\theta dr \quad (7)$$

The limits for inner and outer integral are, respectively: from 0 to 2π , and from 0 to a , that is, the whole extension of the radius of the emitting circle.

In order to solve this double integral, we first integrate with respect to θ . Proceeding with the first integral implies taking out all the constants that are independent of θ , and this yields:

$$b^2 r \cdot dr \int_0^{2\pi} \frac{d\theta}{(r^2 + d^2 + b^2 - 2dr \cdot \cos\theta)^2} \quad (8)$$

Such expression corresponds to a type, which yields the solution:

$$\int \frac{dx}{(B + C \cdot \cos(Ax))^2} = \frac{C \cdot \sin(Ax)}{A(B^2 - C^2)(B + C \cos(Ax))} - \frac{B}{(C^2 - B^2)} \int \frac{dx}{B + C \cdot \cos(Ax)} \quad (9)$$

The change of variables is defined thus:

$$d\theta = dx \quad B = r^2 + d^2 + b^2 \quad C = -2dr \quad A = 1 \quad (10)$$

Before operating, and in order to simplify the otherwise tedious calculations, this expression can be put in simpler form by applying logical deductions. Focusing our attention in the first term of (9):

$$\frac{C \cdot \sin(Ax)}{A(B^2 - C^2)(B + C \cos(Ax))} \quad (11)$$

It can be observed that $\sin(Ax)$ is in the numerator; if $A=1$ the former means that we have $\sin(X)$; but we need to bear in mind that the limits for our defined integral are 2π and 0, thus, $\sin(2\pi)$, $\sin(0)$, equal nil and so does the integral,

$$\left. \frac{C \cdot \sin(Ax)}{A(B^2 - C^2)(B + C \cos(Ax))} \right|_0^{2\pi} = 0 - 0 = 0 \quad (12)$$

Subsequently, we focus our attention in the second term of equation (9);

$$-\frac{B}{(C^2 - B^2)} = -\frac{r^2 + d^2 + b^2}{4d^2r^2 - (r^2 + d^2 + b^2)^2} = +\frac{r^2 + d^2 + b^2}{(r^2 + d^2 + b^2)^2 - 4d^2r^2} \quad (13)$$

So far, we have solved all terms outside the integration sign of equation (9). What remains inside the integral admits this change:

$$\int \frac{dx}{B + C \cdot \cos(Ax)} = \frac{2}{A\sqrt{B^2 + C^2}} \cdot \arctan \frac{(B - C) \cdot \tan(Ax / 2)}{\sqrt{B^2 - C^2}} \quad (14)$$

Therefore, substituting all terms we receive:

$$\frac{r^2 + d^2 + b^2}{(r^2 + d^2 + b^2)^2 - 4d^2r^2} \left[\frac{2}{\sqrt{(r^2 + d^2 + b^2)^2 - 4d^2r^2}} \cdot \arctan \frac{((r^2 + d^2 + b^2) + 2dr) \cdot \tan(\theta / 2)}{\sqrt{(r^2 + d^2 + b^2)^2 - 4d^2r^2}} \right] \quad (15)$$

Once more, some logics were employed in order to compact the calculations; concentrating on the third term of (15), we find an *arctangent* and a *tangent* expression. Bearing in mind that the limits of integration are $(2\pi, 0)$, the result of arctangent is obviously π , and that produces:

$$\frac{r^2 + d^2 + b^2}{(r^2 + d^2 + b^2)^2 - 4d^2r^2} \cdot \frac{2\pi}{\sqrt{(r^2 + d^2 + b^2)^2 - 4d^2r^2}} \quad (16)$$

The value of π is taken out of the integration mark and eliminated by means of the canonical equation of the configuration factor. That yields:

$$2b^2 \int_0^a \frac{r \cdot (r^2 + d^2 + b^2)}{\left((r^2 + d^2 + b^2)^2 - 4d^2r^2 \right)^{3/2}} dr \quad (17)$$

Again making some arrangements to these elements to produce an expression that enables easy integration, let us multiply the numerator and denominator by 4 and add and subtract a new term, $-2rd^2$, always bearing in mind to reproduce the original expression in (17); that gives the following equation.

$$2b^2 \int_0^a \frac{4 \left(r \left(r^2 + d^2 + b^2 \right) - 2rd^2 + 2rd^2 \right)}{4 \left(\left(r^2 + d^2 + b^2 \right)^2 - 4d^2r^2 \right)^{3/2}} dr \quad (18)$$

Decomposing and operating again:

$$\begin{aligned}
 & 2b^2 \int_0^a \frac{4(r^2 + d^2 + b^2) - 8rd^2 + 8rd^2}{4((r^2 + d^2 + b^2) - 4d^2r^2)^{3/2}} dr = \\
 & 2b^2 \int_0^a \frac{4(r^2 + d^2 + b^2) - 8rd^2}{4((r^2 + d^2 + b^2) - 4d^2r^2)^{3/2}} + \frac{8rd^2}{4((r^2 + d^2 + b^2) - 4d^2r^2)^{3/2}} dr = \\
 & 2b^2 \int_0^a \frac{4r(r^2 + d^2 + b^2) - 8rd^2}{4((r^2 + d^2 + b^2) - 4d^2r^2)^{3/2}} dr + \int_0^a \frac{2rd^2}{((r^2 + d^2 + b^2) - 4d^2r^2)^{3/2}} dr \quad (19)
 \end{aligned}$$

The integral of a sum is given, which can be treated as the sum of integrals. Dealing with the first term of (19) the following expression is received:

$$2b^2 \int_0^a \frac{4r(r^2 + d^2 + b^2) - 8rd^2}{4((r^2 + d^2 + b^2) - 4d^2r^2)^{3/2}} dr = 2b^2 \int_0^a \frac{4r(r^2 + b^2 - d^2)}{4((r^2 + d^2 + b^2) - 4d^2r^2)^{3/2}} dr \quad (20)$$

That offers the solution:

$$-b^2 \left[\frac{1}{((r^2 + d^2 + b^2)^2 - 4d^2r^2)^{1/2}} \right]_0^a = \frac{b^2}{d^2 + b^2} - \frac{b^2}{((a^2 + d^2 + b^2)^2 - 4d^2a^2)^{1/2}} \quad (21)$$

Now it is time to proceed to the remaining term of (19)

$$\int_0^a \frac{2rd^2}{((r^2 + d^2 + b^2) - 4d^2r^2)^{3/2}} dr \quad (22)$$

Expanding the denominator and rearranging its terms with reference to the variable r:

$$2b^2 d^2 \int_0^a \frac{2rdr}{(r^4 + 2r^2(b^2 - d^2) + (b^2 + d^2)^2)^{3/2}} \quad (23)$$

Introducing the change of variable $r^2=t$, that yields:

$$2b^2d^2 \int_0^{a^2} \frac{dt}{(t^2 + 2t \cdot (b^2 - d^2) + (b^2 + d^2)^2)^{3/2}} \quad (24)$$

This integral responds to the following model with the solution:

$$\int \frac{dx}{X\sqrt{X}} = \frac{2(2ax + b)}{\Delta\sqrt{X}} \text{ for } X = ax^2 + bx + c \text{ and } \Delta = 4ac - b^2 \quad (25)$$

Making the substitution:

$$a = 1; \quad b = 2(b^2 - d^2); \quad c = (b^2 + d^2)^2; \quad \Delta = 4(b^2 + d^2)^2 - (b^2 - d^2)^2 = 16b^2d^2 \quad (26)$$

The ensuing outcome is given:

$$2b^2d^2 \left[\frac{2(2t + 2b^2 - 2d^2)}{16b^2d^2 \sqrt{(t^2 + 2t \cdot (b^2 - d^2) + (b^2 + d^2)^2)}} \right]_0^{a^2} = \frac{a^2 + b^2 - d^2}{2\sqrt{((a^2 + d^2 + b^2)^2 - 4d^2a^2)}} - \frac{b^2 - d^2}{2(d^2 + b^2)} \quad (27)$$

Finally, adding both terms, from (21) and (27), in order to obtain the final result:

$$\begin{aligned} & \frac{b^2}{d^2 + b^2} - \frac{b^2}{\sqrt{((a^2 + d^2 + b^2)^2 - 4d^2a^2)}} + \frac{a^2 + b^2 - d^2}{2\sqrt{((a^2 + d^2 + b^2)^2 - 4d^2a^2)}} - \frac{b^2 - d^2}{2(d^2 + b^2)} = \\ & \frac{-2b^2 + a^2 + b^2 - d^2}{2\sqrt{((a^2 + d^2 + b^2)^2 - 4d^2a^2)}} + \frac{2b^2 - b^2 + d^2}{2(d^2 + b^2)} = \\ & \frac{a^2 - b^2 - d^2}{2\sqrt{((a^2 + d^2 + b^2)^2 - 4d^2a^2)}} + \frac{b^2 + d^2}{2(d^2 + b^2)} = \\ & \frac{1}{2} - \frac{b^2 + d^2 - a^2}{2\sqrt{((a^2 + d^2 + b^2)^2 - 4d^2a^2)}} \end{aligned} \quad (28)$$

3.2. Direct integration for a differential element to a circular disk on a plane perpendicular to that of element

In the perpendicular plane, that is, the ZX plane, according to the defined coordinate reference system, the main equation to be solved is:

$$\int_0^a \int_0^{2\pi} \frac{br(d - r\cos\theta)}{(r^2 + d^2 + b^2 - 2dr\cos\theta)^2} \cdot d\theta dr \quad (29)$$

This can be decomposed into two terms

$$\int_0^a \int_0^{2\pi} \frac{brd}{(r^2 + d^2 + b^2 - 2dr\cos\theta)^2} \cdot d\theta dr - \int_0^a \int_0^{2\pi} \frac{br^2\cos\theta}{(r^2 + d^2 + b^2 - 2dr\cos\theta)^2} \cdot d\theta dr \quad (30)$$

The first part of this expression has already been solved, but with b^2 instead of $b d$ as a constant. The first term was solved in two parts, which were expressed in equations (21) and (27). From equation (21):

$$-b d \left[\frac{1}{((r^2 + d^2 + b^2)^2 - 4d^2 r^2)^{1/2}} \right]_0^a = \frac{bd}{d^2 + b^2} - \frac{bd}{\sqrt{((a^2 + d^2 + b^2)^2 - 4d^2 a^2)}} \quad (31)$$

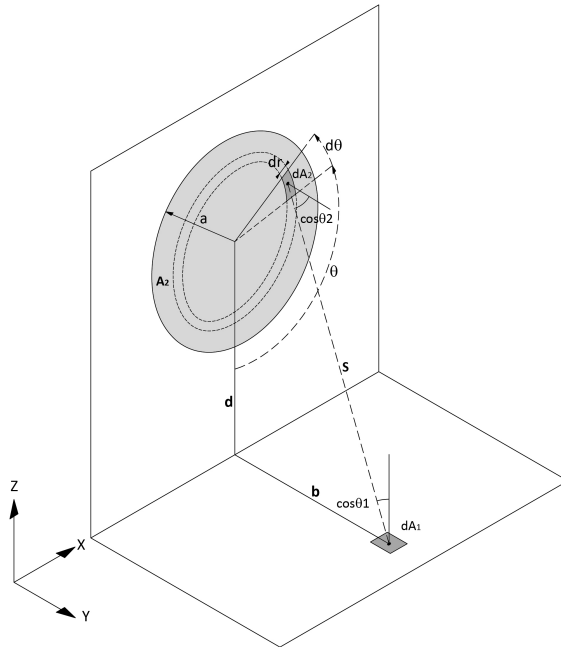

Figure 3. Calculation parameters for the perpendicular plane

Now, equation (27) is rearranged as follows:

$$\begin{aligned}
 & 2bd^3 \left[\frac{2(2t + 2b^2 - 2d^2)}{16b^2d^2 \sqrt{(t^2 + 2t(b^2 - d^2) + (b^2 + d^2)^2)}} \right]_0^{a^2} = \\
 & = 2bd^3 \left[\frac{(a^2 + b^2 - d^2)}{4b^2d^2 \sqrt{((a^2 + d^2 + b^2)^2 - 4d^2a^2)}} - \frac{(b^2 - d^2)}{4b^2d^2(d^2 + b^2)} \right] \\
 & \frac{d(a^2 + b^2 - d^2)}{2b \sqrt{((a^2 + d^2 + b^2)^2 - 4d^2a^2)}} - \frac{d(b^2 - d^2)}{2b(d^2 + b^2)} \tag{32}
 \end{aligned}$$

Next, assemble equations (31) and (32), group terms by common denominator and operate:

$$\begin{aligned}
 & \frac{bd}{d^2 + b^2} - \frac{bd}{\sqrt{((a^2 + d^2 + b^2)^2 - 4d^2a^2)}} + \frac{d(a^2 + b^2 - d^2)}{2b \sqrt{((a^2 + d^2 + b^2)^2 - 4d^2a^2)}} - \frac{d(b^2 - d^2)}{2b(d^2 + b^2)} \\
 & \frac{d(a^2 + b^2 - d^2) - 2b^2d}{2b \sqrt{((a^2 + d^2 + b^2)^2 - 4d^2a^2)}} + \frac{2b^2d - d(b^2 - d^2)}{2b(d^2 + b^2)} = \frac{a^2d - b^2d - d^3}{2b \sqrt{((a^2 + d^2 + b^2)^2 - 4d^2a^2)}} + \frac{b^2d + d^3}{2b(d^2 + b^2)} = \\
 & = \frac{-d(-a^2 + b^2 + d^2)}{2b \sqrt{((a^2 + d^2 + b^2)^2 - 4d^2a^2)}} + \frac{d(b^2 + d^2)}{2b(d^2 + b^2)} = \frac{-d(b^2 + d^2 - a^2)}{2b \sqrt{((a^2 + d^2 + b^2)^2 - 4d^2a^2)}} + \frac{d}{2b} = \\
 & \frac{1}{2} \frac{d}{b} \left[1 - \frac{(b^2 + d^2 - a^2)}{\sqrt{((a^2 + d^2 + b^2)^2 - 4d^2a^2)}} \right] \tag{33}
 \end{aligned}$$

Also, the second term from equations (30):

$$\int_0^a \int_0^{2\pi} \frac{br^2 \cos\theta}{(r^2 + d^2 + b^2 - 2dr\cos\theta)^2} \cdot d\theta dr \quad (34)$$

Again, integrating with respect to θ we receive:

$$\int_0^a \frac{4bdr^2}{\left((r^2 + d^2 + b^2)^2 - 4d^2r^2\right)^{3/2}} \cdot dr \quad (35)$$

Employing the change $r^2=t$ in equation (35),

$$2bd \int_0^{a^2} \frac{t}{\left((t^2 + 2t(b^2 - d^2)) + (b^2 + d^2)^2\right)^{3/2}} \cdot dt \quad (36)$$

An integral that admits the immediate solution:

$$\int \frac{xdx}{X\sqrt{X}} = -\frac{2(2bx + 2c)}{\Delta\sqrt{X}} \text{ for} \quad (37)$$

$$X = ax^2 + bx + c \text{ and } \Delta = 4ac - b^2$$

Making the following substitutions:

$$a = 1; b = 2(b^2 - d^2); c = (b^2 + d^2)^2 \quad (38)$$

$$\Delta = 4(b^2 + d^2)^2 - (b^2 - d^2)^2 = 16b^2d^2$$

Equation (36) becomes:

$$2bd \left[\frac{(b^2 - d^2)t + (b^2 + d^2)^2}{4b^2d^2\sqrt{t^2 + 2t(b^2 - d^2) + (b^2 + d^2)^2}} \right]_0^{a^2} = \frac{a^2(b^2 - d^2) + (b^2 + d^2)^2}{2bd\sqrt{(a^2 + b^2 + d^2)^2 - 4a^2d^2}} - \frac{b^2 + d^2}{2bd} \quad (39)$$

Finally, in order to produce the final solution for the perpendicular plane, it is required to assemble equations (33) and (39). Grouping and rearranging by common denominators it yields:

$$\begin{aligned}
& \frac{d}{2b} - \frac{d(b^2 + d^2 - a^2)}{2b\sqrt{(a^2 + d^2 + b^2)^2 - 4d^2a^2}} + \frac{a^2(b^2 - d^2) + (b^2 + d^2)^2}{2bd\sqrt{(a^2 + b^2 + d^2)^2 - 4d^2a^2}} - \frac{b^2 + d^2}{2bd} \\
& \frac{a^2b^2 - a^2d^2 + b^4 + d^4 - 2b^2d^2 - b^2d^2 - d^4 + a^2d^2}{2bd\sqrt{(a^2 + b^2 + d^2)^2 - 4d^2a^2}} + \frac{d^2 - b^2 - d^2}{2bd} \\
& \frac{b^2(a^2 + b^2 + d^2)}{2bd\sqrt{(a^2 + b^2 + d^2)^2 - 4d^2a^2}} - \frac{b^2}{2bd} \\
& \frac{b}{2d} \left[\frac{a^2 + b^2 + d^2}{\sqrt{(a^2 + b^2 + d^2)^2 - 4d^2a^2}} - 1 \right] \tag{40}
\end{aligned}$$

Again, this result can be checked against usual formulas that appear in numerous configuration factor catalogues, although those do not completely solve the problem. Only they work when the element is in a plane that passes through the center of the circle. A more general solution of a vector nature had been presented by the authors in other texts [6],[7]. In this chapter a sound relationship between the two fundamentals expressions has been found.

3.3. Resolution of the integral for the third coordinate plane

Being radiation a vector, the resolution for a third coordinate plane that obviously cuts the emitting circle in two halves is required; the outline of the integral in this case yields:

$$\int_0^a \int_0^\pi \frac{br^2 \sin\theta}{(r^2 + d^2 + b^2 - 2dr\cos\theta)^2} \cdot d\theta \cdot dr \tag{41}$$

In this particular case, the limits of the integral cannot be extended to 2π , as the value would be nil. If (41) is integrated with respect to θ , in the numerator the derivatives of $\cos\theta$, $-\sin\theta$ could be found. Therefore by making this change:

$$t = \cos\theta \quad dt = -\sin\theta d\theta \tag{42}$$

Integral (41) can therefore be expressed as:

$$\int_0^a \int_{-1}^1 \frac{-br^2}{(r^2 + d^2 + b^2 - 2drt)^2} \cdot dt \cdot dr \tag{43}$$

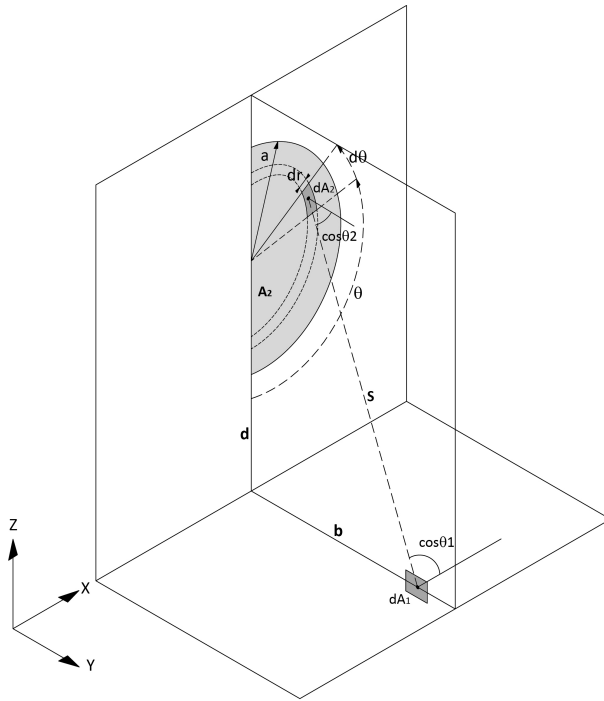

Figure 4. Calculation parameters for the semicircle

Taking out all the constants, and integrating with respect to r , the primitive is just the quotient of the numerator:

$$\frac{-br^2}{2dr} \left[\frac{1}{r^2 + d^2 + b^2 - 2dr} \right]_1^{-1} = \frac{br}{2d} \left(\frac{1}{r^2 + d^2 + b^2 - 2dr} - \frac{1}{r^2 + d^2 + b^2 + 2dr} \right) \quad (44)$$

Integrating (44) with respect to r ; the last integral to solve is:

$$\int_0^a \frac{r}{r^2 + d^2 + b^2 - 2dr} \cdot dr + \int_0^a \frac{r}{r^2 + d^2 + b^2 + 2dr} \cdot dr \quad (45)$$

That responds to the form:

$$\int \frac{x \cdot dx}{X} = \frac{1}{2a} \cdot \ln X - \frac{b}{2a} \int \frac{dx}{X} \quad X = ax^2 + bx + c \quad \Delta = 4ac - b^2$$

$$\int \frac{dx}{X} = \frac{2}{\sqrt{\Delta}} \arctan \frac{2ax+b}{\sqrt{\Delta}} \quad (46)$$

Substituting in (46) yields for both terms:

$$a = 1; b = \pm 2d; c = (d^2 + b^2)$$

$$X = r^2 \pm 2dr + (d^2 + b^2) \quad \Delta = 4b^2 \quad (47)$$

Now, substituting in the first term of (45):

$$\frac{1}{2} \left[\ln(r^2 + d^2 + b^2 - 2dr) \right]_0^a + \frac{d}{b} \left[\arctan \left(\frac{r-d}{b} \right) \right]_0^a \quad (48)$$

And bringing equation (48) to the limits of the integral [a,0]:

$$\frac{1}{2} \left(\ln(a^2 + d^2 + b^2 - 2da) \right) - \ln(d^2 + b^2) + \frac{d}{b} \left(\arctan \frac{a-d}{b} + \arctan \frac{d}{b} \right) \quad (49)$$

In a similar way, for the second term of equation (45):

$$-\frac{1}{2} \left(\ln(a^2 + d^2 + b^2 + 2da) \right) + \ln(d^2 + b^2) + \frac{d}{b} \left(\arctan \frac{a+d}{b} - \arctan \frac{d}{b} \right) \quad (50)$$

Finally, multiplying by $\frac{b}{2\pi d}$ and grouping, the final result can be expressed as:

$$\frac{1}{2\pi} \left(\arctan \frac{a+d}{b} + \arctan \frac{a-d}{b} \right) + \frac{b}{4\pi d} \ln \frac{a^2 + b^2 + d^2 - 2ad}{a^2 + b^2 + d^2 + 2ad} \quad (51)$$

It can be demonstrated that the former equates the area subtended by a circular sector that encompasses the diameter of the emitting disk and the corresponding sector of a hyperbola defined by the intersection of the unit sphere and the cone [7].

If $a=d$, the factor is,

$$\frac{1}{2\pi} \arctan \frac{2a}{b} - \frac{b}{4\pi d} \ln \frac{4a^2 + b^2}{b^2} \quad (52)$$

Where the former assert is more easily visualized.

If $d=0$ the expression is undetermined and the limit is passed with l'Hôpital's rule, obtaining the familiar result.

$$\frac{1}{\pi} \left(\arctan \frac{a}{b} - \frac{ab}{a^2 + b^2} \right) \quad (53)$$

Equation (51) is entirely new and has never been mentioned in literatures; equation (52) constitutes a particular case of the former, that is, when a equals d , meaning that the receiving point lies on the edge of the emitting semicircle; equation (53) is the particular case in which the receiving point is aligned with the center of the half-disk.

3.4. Extension to three dimensional emitters – Configuration factor between a sphere and a differential element placed at a random position

After analyzing the previous form factors for the circle, a new question can be deduced. A sphere can be considered, in terms of radiative transfer as a circle [7], as the viewed area of the said sphere from a distant point equals always a circle, because only half of the emitter is visible. Let us consider as emitting source a sphere of radius r , and a differential element, placed randomly in space at a distance (x,y,z) , referenced to the three coordinate directions as shown in figure 5:

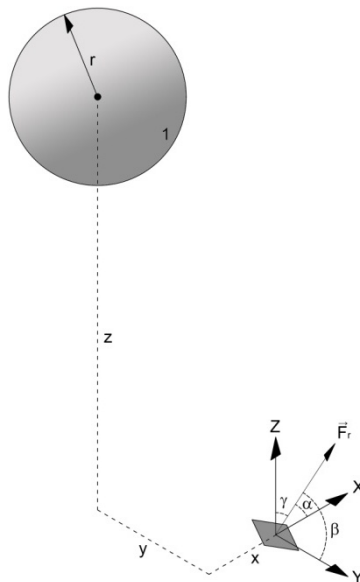

Figure 5. Calculations parameters for the sphere and a differential element at a random position

The differential element, as in former cases, is defined by its normal, and it is necessary to find the radiation vector \vec{F}_r impinging on it. Obtaining the modulus (configuration factor) is a direct operation, the angles formed by the unit element are already known:

$$|\vec{F}_r| = F_{d1-x} \cdot \cos \alpha + F_{d1-y} \cdot \cos \beta + F_{d1-z} \cdot \cos \gamma \tag{54}$$

And expanding each of them,

$$F_{d1-x} = \frac{r^2 \cdot x}{\sqrt{(x^2 + y^2 + z^2)^3}}$$

$$F_{d1-y} = \frac{r^2 \cdot y}{\sqrt{(x^2 + y^2 + z^2)^3}}$$

$$F_{d1-z} = \frac{r^2 \cdot z}{\sqrt{(x^2 + y^2 + z^2)^3}} \tag{55}$$

3.5. Configuration factor between a sphere and a plane.

Extending the previous deduction to a finite rectangle located at a certain distance to the sphere in a random position (figure 6), a new unknown factor has been deduced:

$$F_{A1-A2} = \frac{1}{4\pi} \left(\arctan \frac{x_2 y_2}{z \sqrt{x_2^2 + y_2^2 + z^2}} - \arctan \frac{x_2 y_1}{z \sqrt{x_2^2 + y_1^2 + z^2}} - \arctan \frac{x_1 y_2}{z \sqrt{x_1^2 + y_2^2 + z^2}} - \arctan \frac{x_1 y_1}{z \sqrt{x_1^2 + y_1^2 + z^2}} \right) \tag{56}$$

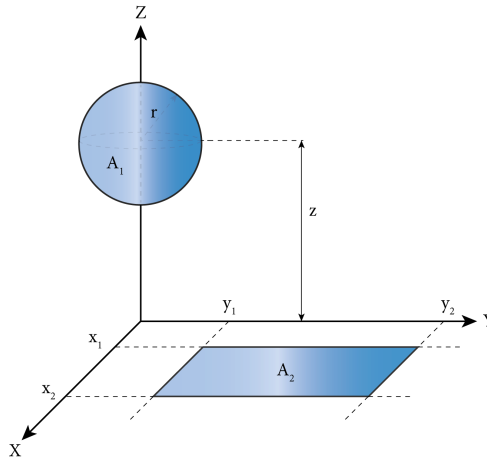

Figure 6. Configuration factor between a sphere and a parallel plane

4. Graphical visualization

To help visualize the results of this research, some formulas have been programmed by the authors in Matlab® computational language, which greatly enhances understanding of radiative exchange between emitting surfaces and receiving planes. 3D graphs have been produced for a generic semicircular emitter.

Figure 7 shows a generic semicircular emitter that gives energy to a perpendicular plane in its base. Thanks to this new configuration factor, several radiative properties for these shapes can be clarified. For instance, a semicircular emitter is not capable of transferring more than 50% of its energy to a perpendicular plane; this is particularly important in some engineering lighting applications, such as lighted vaults or tunnels.

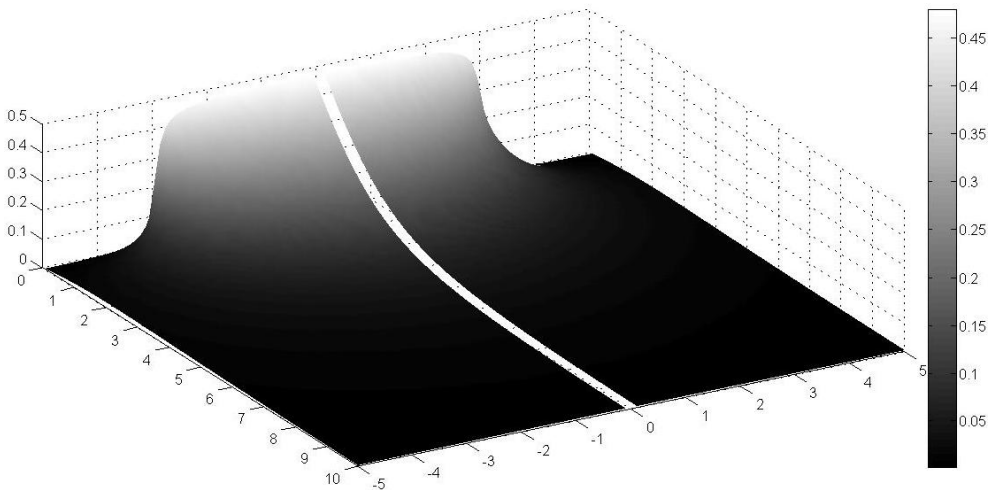

Figure 7. The radiative field generated by a half disk of radius 3m. Over the perpendicular plane that contains the straight edge of the disk in a grid of 10 by 10 m.

Such new configuration factors can also be employed in the analysis of the architectural heritage in terms of environmental values and specifically in natural lighting; as was stated in the beginning of this chapter, several of these paradigms of architecture feature a balanced treatment of natural lighting coming from the sun but, as no calculation methods were available, their designs were merely the result of intuition and happenstance.

These new configuration factors find application in bringing light to the understanding of the said designs. In this sense, the authors would like to present the simulation cases of two epitomes of ancient Roman architecture, whose accurate radiative performance was largely unknown: the Pantheon (Figures 8, 9) and its superb baroque evolution the Church of Sant'Andrea all Quirinale (Figures 10, 11, 12).

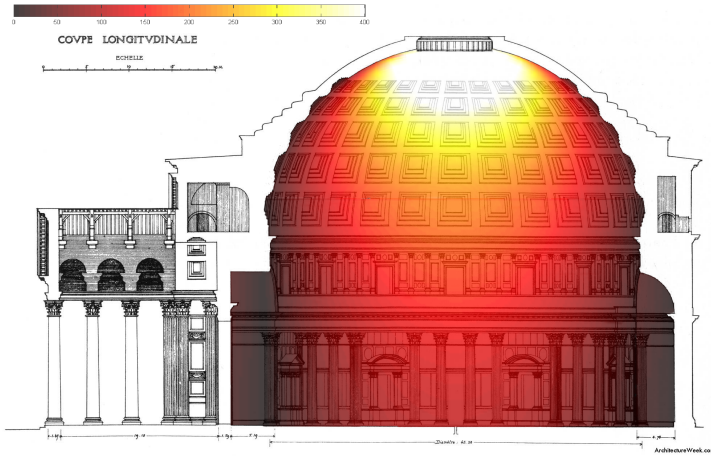

Figure 8. The Roman Pantheon illuminated by diffuse radiation of an intensity of 10000 lumen/m² (lux). Typical situation in autumn and spring. Scale 0 to 400 lux.

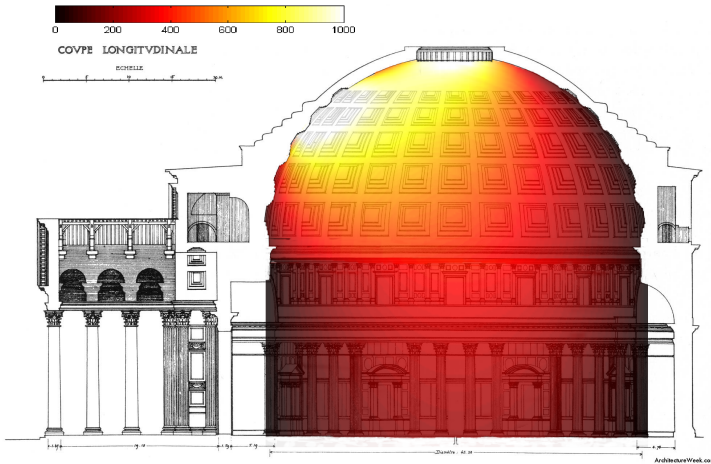

Figure 9. Simulations of the lighting field inside the Pantheon under clear sky conditions.

In Figures 8 and 9, luminous radiation is dimmed and constant for the lower spaces. It is outlined that the values for the Pantheon were not significant (sometimes, under 200 lux) and this fact may have led to the introduction of vertical windows in the drum of the cylinder by late Renaissance or Baroque epochs. Differences in the peak levels are remarkable (400 lux and 1000 lux) due to the amount of energy coming from the sun and the sky; also, in figure 9 the solar penetration inside the Pantheon can be distinctly noticed due to the reflection on the left side of the drawing. These simulations were only possible; thanks to the new configuration factors for circular emitters presented in this text.

Radiative performance does not show an acute seasonal variation, but allows for sunshine to reveal certain decorative details of the structure adding to the reputation of spiritual luminous atmosphere that encompass the work of Bernini (Figures 10, 11, 12).

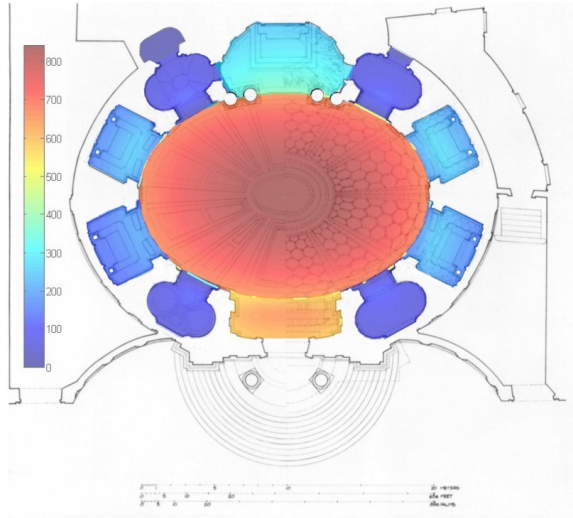

Figure 10. Plan of Sant'Andrea all Quirinale's Church by Bernini (Rome) illuminated by direct solar radiation in winter. Values in lux (0-800)

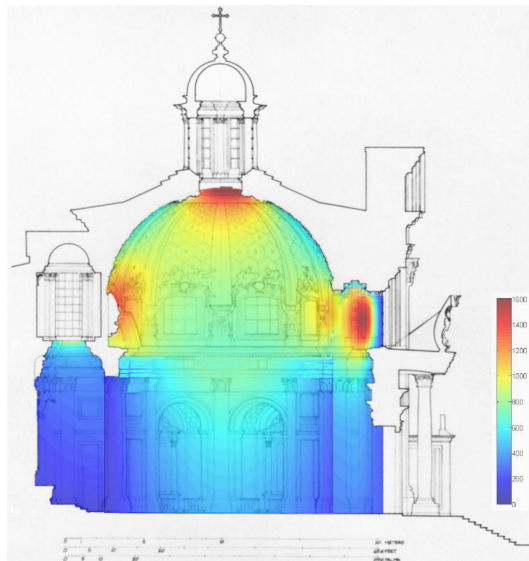

Figure 11. Sant'Andrea all Quirinale's Church. Transversal Section under direct solar radiation in winter. Values in lux (0-1600)

The architect and sculptor of light, Gian Lorenzo Bernini completed this masterwork, considered to be his own spiritual retreat (Figure 12) and paved the way for further illumination achievements by Guarino Guarini Figure 13).

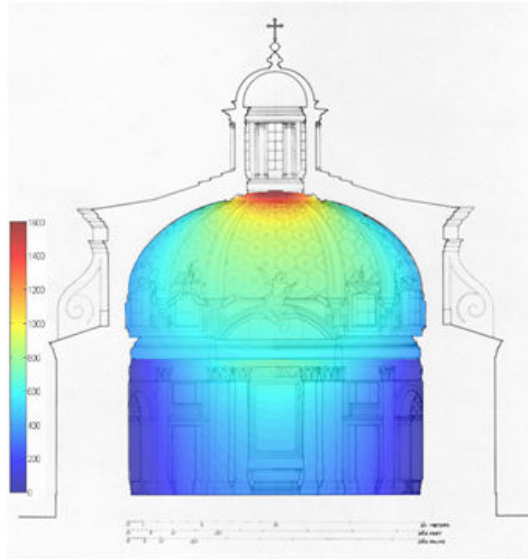

Figure 12. Sant'Andrea all Quirinale's Church. Longitudinal section under direct solar radiation in winter. Values in lux (0-1600)

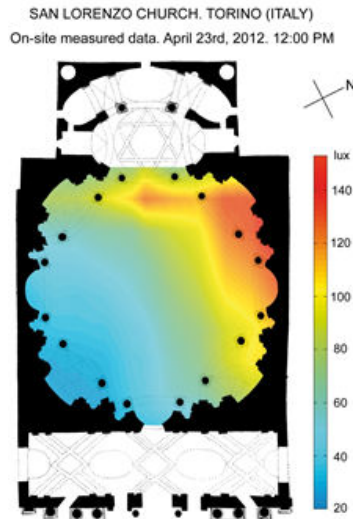

Figure 13. Values measured at Guarini's church in Torino

In the same fashion of studying radiation due to circular emitters, a building currently under construction, the new railway station at the airport of Barcelona (Spain) is briefly presented in an effort to show how simulation can help in the design process and assessment (Figures 14, 15).

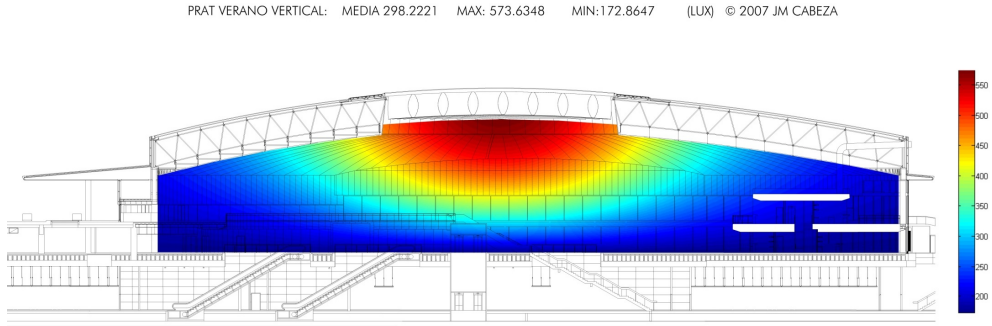

Figure 14. Section of the new railway station in Barcelona. Radiative performance design by the author. Project by the architects Cesar Portela and Antonio Barrionuevo. Values in lux (0-600)

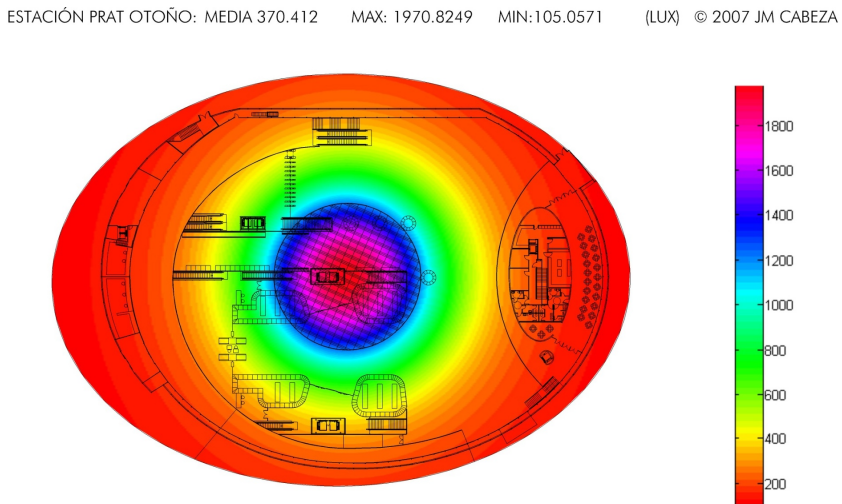

Figure 15. Plan of the railway station in autumn. Values in lux

Changing the scale for the modern requirements of transportation spaces which have become the cathedrals of our time, the author proposes a lighting design in which the oculus reaches a diameter of 30 metres and the radiative energy is distributed by means of massive aluminium louvers with a height exceeding 3 metres in total. The simulations show good values in winter and summer and an acceptable raise of temperature levels at the glazed aperture due to the solar protection and the mild climate of Barcelona.

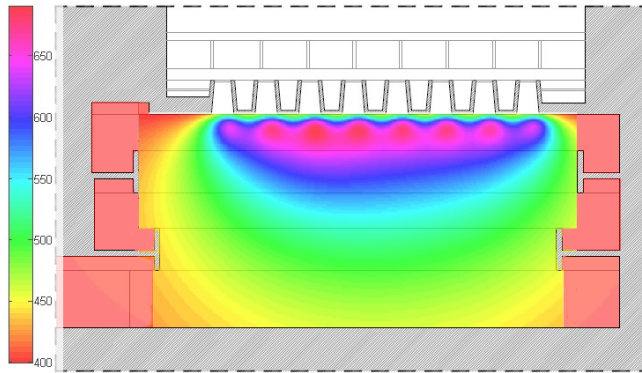

Figure 16. The Rautatalo building of 1955 by Alvar Aalto, Helsinki. Simulation of 40 skylights (8*5), performed in June with direct sunlight and monitored on 21st of June 2011. Values in lux

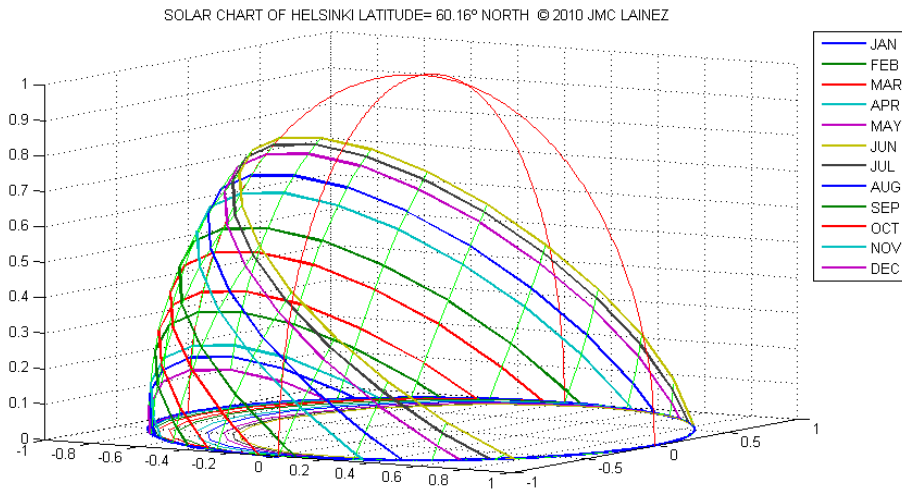

Figure 17. Solar chart of Helsinki. Latitude 61.16 degrees North

The final case to be introduced is the Rautatalo building of 1955, by the modern Finnish master Alvar Aalto. Originally a department store, it beckoned Helsinki’s citizens by its intelligent use of luminous radiation, enhanced by conical skylights subtly adapted to the solar path in this lively northern city. (Figures 16, 17)

The latter example, the Rautatalo building, brings the reader back to the efforts of the modern movement in architecture to control radiation. With 40 circular skylights it was subsequently

adapted to many projects around the world, which generally speaking fared less well than the original for climatic and economic circumstances.

5. Conclusions

In this chapter four new configuration factors related to circular emitters have been presented. They have been deduced via direct analytical work, solving the integral according to the canonical expression of the theory of configuration factors.

In this sense, the components of the radiative field for the three directions of the space with respect to a circular emitter have been found. It is important to stress that thanks to this new factor radiative field can be assessed in any point of the space. In this way, former restrictions regarding the position of the receiving point [8],[9] have been superseded by the new expressions.

It is suggested that several complex surfaces can be estimated in a similar manner, provided that they allow for some decomposition into clusters of tangent circular elements; to perform this operation only the direction of the normal vector at each point considered is needed. With the aid of CAD software and simulation programs, such procedure is readily facilitated.

Following mathematical deduction this factors can be extended to three-dimensional emitters; the case of a spherical source is remarkable, as the viewed portion of a sphere from a receiving differential element can be assimilated to a circular emitter. Extension of this factor for a finite receiving surface, that is, a rectangle, allows for more complex calculations.

After this mathematical deduction, advances in the practical application of these new factors have been presented, mainly in the field of lighting engineering, natural lighting in architecture and thermal engineering but also in human comfort and medicine areas. The architectural examples, a set of climate-responsive buildings would remind the reader that, in order to produce universal results there is the need to consider local weather parameters.

Such a meticulous task can only be achieved in the case of solar radiation with the help of scientific Approach that we believe to have greatly facilitated by the discovery of new expressions to regulate the transfer of energy due to circular and other curved emitters and by creating and diffusing powerful and simple computer programs that successfully implement the desired algorithms.

Acknowledgements

Jose M Cabeza is grateful to the extraordinary librarians at Kansai Gaidai University (Japan). Professors Junko and Tsubasa were always very helpful. The authors would like to thank Juan Manuel Bonilla Martinez for his excellent drawing of figure 6.

Author details

Jose M. Cabeza-Lainez^{1,2*}, Jesus A. Pulido Arcas³, Carlos Rubio Bellido¹,

Manuel-Viggo Castilla¹, Luis Gonzalez-Boado¹ and Benito Sanchez-Montanes Macias¹

*Address all correspondence to: crowley@us.es

1 Universidad de Sevilla, Spain

2 Kansai Gaidai University, Japan

3 Canon Foundation Fellow, University of Shiga Prefecture, Japan

References

- [1] John R. Howell, A Catalogue of Radiation Heat Transfer Configuration Factors. 3rd ed., 2010. On-line version available at: <http://www.engr.uky.edu/rtl/Catalog/>.
- [2] M.H.N. Naraghi, Radiation view factors from differential plane sources to disks – a general formulation, *J. Thermophys. Heat Trans.* 2 (3) (1988) 271–274
- [3] M.H.N. Naraghi, B.T.F. Chung, Radiation configuration between disks and a class of axisymmetric bodies, *J. Heat Transfer* 104 (3) (1982) 426–431.
- [4] Howell. R. John, Siegel. Robert, Mengüç. M. Pinar. *Thermal Radiation Heat Transfer* 5th edition. CRC Press 2010.
- [5] Bronstein. Mr, Semendaev. R, *Handbook of mathematics*. Springer, 2007.
- [6] J.M. Cabeza-Lainez, J.A. Pulido-Arcas, New configuration factors for curved surfaces, *J. Quant. Spectrosc. Radiat. Transfer* 117 (2013) 71–80.
- [7] J.M. Cabeza-Lainez, *Fundamentos de Transferencia Radiante Luminosa. (Including software for simulation)*, Netbiblo, Spain, 2010.
- [8] K.G.T. Hollands, On the superposition rule for configuration factors, *J. Heat Transfer* 117 (1) (1995) 241–245.
- [9] D.C. Hamilton, W.R. Morgan, *Radiant-interchange configuration factors*, NASA TN 2836, 1952.